

Inside

WIND

WELCOME TO
THE WIND AGE

BUILDING TRUST





THE COMING OF AGE FOR WIND

The wind market is coming to a turning point in its development; it is growing up. Wind energy has shown that it can reliably contribute utility scale, clean green energy, but for wind to be completely sustainable it requires new technologies and materials to be introduced to achieve true material circularity. In this edition we will explore some of the ways wind can become more sustainable.

At the heart of what we do at Sika lies the deep conviction that what we do matters. We see ourselves as an enabler, unlocking performance levels previously impossible to achieve whilst having a positive impact on sustainability.

70% of our sales are already generated with products that have a positive effect.

A massive expansion in wind energy production is vital for a sustainable future. However, many of the materials, processes and designs historically used in turbine production have already reached their limits. To achieve the targets set by the Paris Agreement and COP26, the current annual rate of wind installations needs to increase fourfold.

This will demand intense collaboration between designers, manufacturers, contractors and technology suppliers to profitably address unique challenges such as creating rotor diameters of unprecedented lengths. As a key supplier to the wind industry since the 1990s, Sika has already overseen dramatic industrial and design shifts.

We will continue to support our wind customers with new products and process expertise to achieve these bold targets. Together, we are building a new generation of wind turbines with the unparalleled performance and longevity that the world needs.



*Claire Thorey,
Global Head Wind Energy
at Sika AG*

Editorial contributors

Claire Thorey
Charles Awbery-Maskell
Shinta Simon
Laura Lopez

Technical contributors

Simon Leu
Claudio di Fratta
Jeffrey Chen

Layout/graphics

Open Communications AB

Contact

Tuffenweis 16
CH-8048 Zurich
Switzerland
wind@ch.sika.com

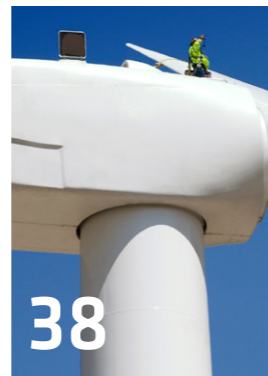

- 6 Extreme durability for extreme lengths
- 12 Rise of the Goliath
- 16 Foundations for the future
- 18 16 steps to successful grouting
- 20 How to improve cartridge application performance
- 22 Reliable repair injection
- 26 Better bonding by design
- 30 The emergence of concrete printing
- 32 The polyurethane paradox
- 34 Closing the concrete circle
- 38 Beyond welding
- 42 Product news

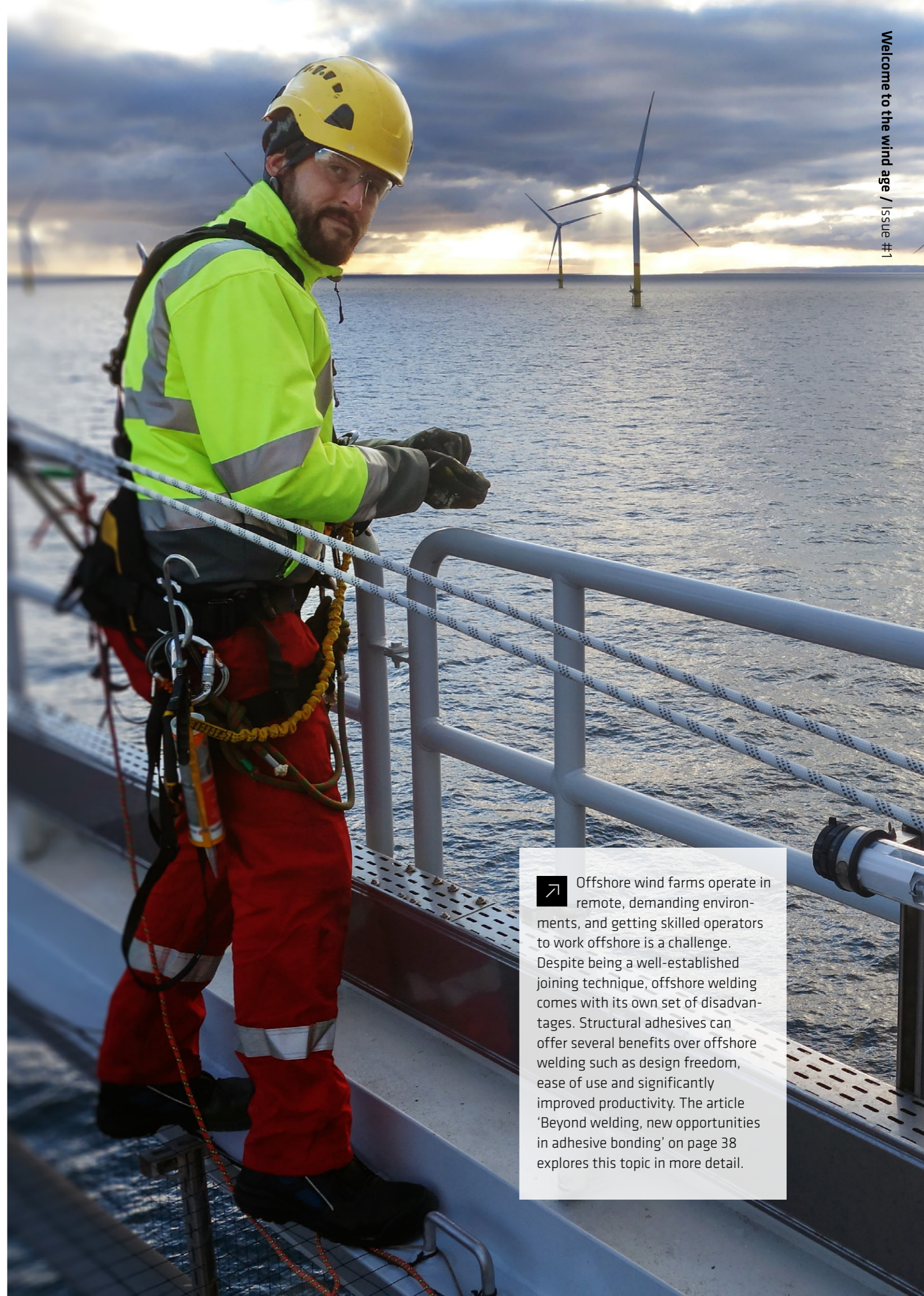

➤ Offshore wind farms operate in remote, demanding environments, and getting skilled operators to work offshore is a challenge. Despite being a well-established joining technique, offshore welding comes with its own set of disadvantages. Structural adhesives can offer several benefits over offshore welding such as design freedom, ease of use and significantly improved productivity. The article 'Beyond welding, new opportunities in adhesive bonding' on page 38 explores this topic in more detail.

➤ Since the first gigawatt of offshore wind was installed in Northern Europe in 2007, this technology has become an important growth area for the generation of renewable energy. Offshore wind now accounts for 7% of the global installed capacity. The market is expected to continue to grow at a CAGR of 26% by 2030, by which time offshore wind will account for around 15% of the global installed capacity. In 2021, China emerged as the main offshore market. By 2030, the AP region is expected to account for 40% of all offshore wind capacity because of projected growth in countries such as Japan, Taiwan, South Korea and Vietnam. ➔

EXTREME DURABILITY FOR EXTREME LENGTHS





GROWTH IN OFFSHORE WIND PROJECTS

The main driver for the exceptional growth in offshore wind is the fact that at sea, the wind blows stronger and more consistently at lower altitudes than on land, due to the absence of natural and man-made obstructions such as mountains, forests and tall buildings. This leads to a significantly higher energy output for offshore wind farms. To benefit from these constant wind conditions, higher capacity generators are typically utilized, which require much longer wind blades to drive them. For onshore projects, the increasing wind blade size is a major challenge due to increasing hub heights and transport restrictions. However, the size is easier to manage for offshore projects. Often, the existing road networks limit access of larger blades to the wind park, but for offshore wind parks, the transport can be easily managed by ship. Generator capacity and consequently, rotor diameters have rapidly increased in recent years to allow for this growth. Wind blades now regularly exceed 100m in length for offshore use.

SIKA CHINA ACHIEVES A BREAKTHROUGH IN WIND TURBINE BLADE BONDING

In September 2021, the Industry team of Sika China achieved a key milestone in the manufacturing of offshore wind turbine blades. Together with a major Chinese blade manufacturer, a 102m wind turbine blade was successfully bonded using SikaPower® epoxy adhesive. At the time, the blade type S102 was the longest wind blade fully engineered, designed and built in China. The S102 blades are due to be fitted to the 11MW offshore turbine for use in the Chinese offshore market.

SikaPower® SmartCore® technology was selected for bonding the main shear-webs as well as the leading and trailing edge joints based on its outstanding fatigue performance from Sika's unique, highly toughened epoxy formulation. Originally designed for the automotive industry, the patented SikaPower® SmartCore® toughening technology enables a drastic increase in toughness without an undesirable drop in stiffness and load-carrying mechanical properties. SikaPower® two-component epoxy adhesives with incorporated SmartCore® domains display a superior level of toughness by retaining extremely high mechanical properties, resulting in the highest fatigue performance level.

"These extremely long blades demand new types of durable, cost-effective bonding solutions. With one of the best toughened blade bonding adhesives on the market, Sika truly delivered for our customer."



Jeffrey Chen
National Sales Manager

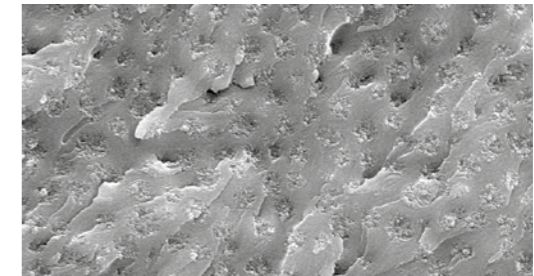

Electron microscope image of a fracture surface of a Sika SmartCore® toughened epoxy

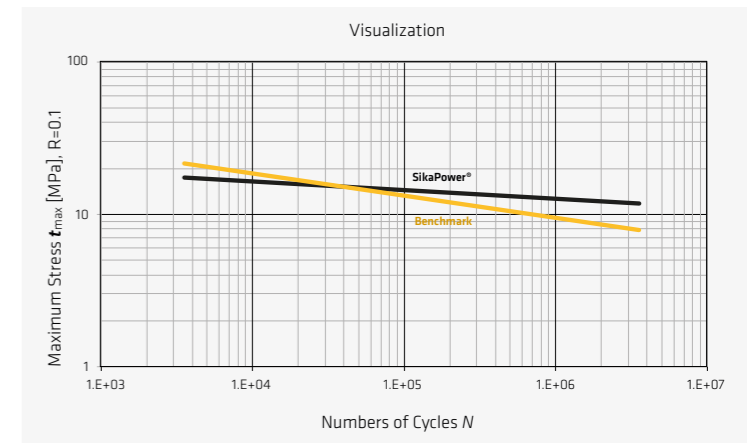

Simplified Wohler Fatigue curve of toughened SikaPower® SmartCore® vs. traditional epoxy products



The S102 wind blades were bonded with SikaPower®-1280, a long open time, second generation blade bonding adhesive. This low-density adhesive offers very good non-sag properties for the application of large bead dimensions on vertical surfaces, even on heated warm substrates. In contrast to many competitors' products, the adhesive is free from solvents and is non-glass filled. The extremely high toughness level offers resistance against crack initiation and propagation at high loads and thus enables thinner bond lines with superior fatigue performance.





WORKING TOWARDS OUR SUSTAINABILITY GOALS

Sika's Research and Development Team is continuously working on improving our blade bonding adhesives based on customers' feedback and requirements. The latest generation of SikaPower®-830 adhesive platform addresses our customers' requirements for regional production and supply. Alongside Sika Germany, the next-generation SikaPower®-830 adhesive is now manufactured in Sika China and Sika USA to the same specification and quality using locally sourced materials. This recently led to DNV-GL certifying the product at all regional manufacturing sites according to DNGLV-CP-0086.

Now, with Sika India setting up a fourth production site that is already in its planning stage, Sika will be well placed to support customer needs for both the present and the future. A major benefit of the shorter supply chain and the use of locally available raw materials is an estimated reduction of up to 1,750t annually of CO₂ emissions which significantly contributes to the ambitious sustainability goals of all our customers.

Sika is looking forward to driving new blade models of increased size to market with its unique solution and thus enabling the energy transition to affordable renewable energy solutions. ■

RISE OF THE GOLIATH

Enabling a new generation of offshore infrastructure



➤ The Jiangsu Rudong offshore converter station was constructed with Sika's offshore wind turbine engineered grout, making its own contributions towards sustainable development.

With the development of offshore wind power in China, offshore booster stations weighing more than 3,000 tons have become increasingly common. In the summer of 2021, the world's largest and Asia's first offshore converter station, dubbed the "Goliath at sea", was successfully installed in the Huangshayang sea area of Rudong, Jiangsu Province.

The Jiangsu Rudong Offshore Converter Station weighs 22,700 tons. It consists of an upper block and a lower jacket foundation. The upper block is 89m long, 84m wide and 44m high, covering an area greater than the sum of 17 international-standard basketball courts. Its height is approximately equal to a 15-story building, and the weight is close to the sum of the weights of 7-8 ordinary offshore booster stations. The lower jacket foundation is truss structured and is divided into two parts, each about 80m long and 16m wide, with a total weight of more than 4,500 tons, which makes it the largest jacket built in China so far.

The Jiangsu Rudong Offshore Converter Station is the first flexible HVDC-based offshore wind farm project in China, which can effectively address the challenges of large-capacity and long-distance transmission presented by offshore wind farms. Once

completed and connected to the grid, the project will generate 2.4 billion kWh annually, which is equivalent to the annual power consumption of 990,000 households.

The converter station was constructed with Sika's offshore wind turbine engineered grout. The jacket grouting at the offshore wind farm involved a short construction window and a complicated construction process. As China's first offshore converter station, the Jiangsu Rudong Offshore Converter Station demanded a grout with high levels of construction performance, underwater segregation resistance and mechanical properties.

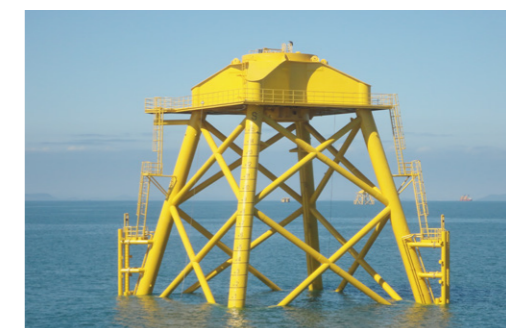

SikaGrout® offshore wind turbine engineered grout series offers the following advantages:

- Ultra-long operable time
- Excellent flowability
- Underwater non-dispersibility
- Fast early strength growth
- High final strength

In the future, the Converter Station will pool 1.1 million kilowatts of electricity produced by Rudong H6, H8 and H10 offshore wind farms, convert it into DC with lower loss and transmit it to onshore facilities. This solution can more efficiently address the challenges of large-capacity and long-distance transmission presented by offshore wind farms, which helps set a model for the industry. Adhering to the policy of "Swiss technology + local support", Sika China provides services for the development of offshore wind farms in China with professional products and technologies that adapt to China's local conditions, thereby contributing in a significant way towards sustainable development. ■



FOUNDATIONS FOR THE FUTURE

➤ Energy is instrumental in shaping the progress of human civilization. Many countries are currently developing new sources of energy, including wind energy. Although offshore wind is growing exponentially, onshore wind is still the preferred option in many countries due to the long experience in this area, the costs of installation, transport of electricity and maintenance, among other factors.

WIND FARM 4-6, FOKIDA, GREECE

The project involved the construction of 12 x GE103- 3.2MW wind turbines manufactured by General Electric. Each tower had a hub height of 85m and with blade lengths of 50.2m, this wind farm is expected to generate enough electricity to power more than 27,000 households in Greece.

After extensive testing, SikaGrout®-3200 was found to be the optimal product for grouting between the foundation and tower flange. The product has excellent fatigue properties ensuring the material's suitability for meeting the dynamic loads experienced during the service life. To further enhance the durability of the base, a polyurethane protection and waterproofing system based on MTC technology was applied. Sikalastic®-601 BC with Sika® Reemat Premium embedment, along with Sikalastic®-621 TC as topcoat, was selected as the optimal solution. ■



HOW TO: Onshore grouting made easy

In the wind industry, the use of ultra-high performance grouts has become increasingly important. Wind turbines need to be secured to the foundation to ensure that they are firmly in place. It is also imperative that wind turbines provide long-lasting optimal performance until the end of their service life.

Epoxy or cementitious grout is filled between the base of the tower and the top of the foundation. These grouts are pumped into the intersection and, once fully cured, are used to transfer loads from the tower down into the foundation, to provide greater stability, tower alignment, vibration isolation and levelling.

Ensuring the durability and low maintenance of infrastructure has a direct impact on sustainability. The installation process for grouting is key for achieving a long-lasting base for the wind turbine.

For these reasons, it is important to check not just the quality and performance of the material, but also the application techniques that accompany it.



16 STEPS TO SUCCESSFUL GROUTING



1. CONFIRM THE QUANTITY OF GROUT NEEDED

Count the number of bags to ensure that the right amount of grout is available before starting the mixing of the material. This value needs to be recorded by the grouting contractor before the procedure begins.



2. RECORD WEATHER CONDITIONS AND CHECK NECESSARY PROTECTION MEASURES FOR THE APPLICATION

During the application, the substrate and ambient temperatures should be recorded and controlled. Ambient humidity also needs to be taken into consideration for the water ratio and the curing methods. The values should be recorded by the grouting contractor before and during the grouting works.

If rain is expected, a shelter or tent must be installed before pouring the grout to avoid any rain damage.



3. TIMING AND PLANNING FOR BREAKS

Breaks should be planned so that there is no interruption in mixing; maintain a continuous pouring process per foundation and avoid stop-go during the application. The detailed plan should be indicated by the contractor for each specific project so that breaks are accommodated for.



4. CONFIRM POWER AND WATER SUPPLIES

Power for equipment should be approved for use for each project. Always conform to local laws and restrictions when using diesel powered equipment. When using an electric motor, check to see if the voltage requirement is available on the job site. Check to confirm if there is an adequate supply of clean water on the job site to fill the bowser or IBC containers.



5. SUBSTRATE PREPARATION

Cleaning the substrate with high water pressure. This is essential to ensure that no loose particles will block the areas where the grout needs to flow.



6. INSPECTION OF THE SUBSTRATE

The concrete substrate in the area to be grouted should be inspected in advance to check for cracks and other defects, and should be repaired accordingly for each specific project.



7. INSTALLATION AND CHECKING THE FORMWORK

Install the formwork and seal it. It should be waterproof to avoid leaks.



8. PREPARATION OF THE EQUIPMENT

- Ensure that the equipment is functioning correctly.
- Verify that the right amount of grout and water is available. Account for at least 10% of excess material.
- Check to see if the QC devices are ready.
- Check the hose, including its length, arrangement, and couplings. Do not use hydraulic hoses.
- Prepare the grout lines. You can lubricate them with cementitious slurry made of cement and water or a pre-batch slurry.
- Verify that the substrate is properly prepared and pre-wet before starting the pumping procedure.
- The mixing of the SikaGrout® must be done only with clean water, without any other additional products. Refer to the latest product data sheet of the grout before starting the mixing process.
- The SikaGrout® can be mixed with a low hand drill mixer for very small quantities or using a force action mixer. (Refer to the product data sheet for detailed instructions).



9. QUALITY CONTROL

The required QC protocol must be agreed before starting the grouting works with the responsible supervisor. The grouting contractor must fill in the quality control sheets during the grouting works.



10. GROUTING PROCESS: MIXING AND PUMPING

Mix the grout with the right amount of water according to the ambient conditions. Once a homogeneous mix is achieved, normally after ~5 minutes of mixing, start pumping.



11. QUALITY CONTROL: FILL THE CHECK LIST



12. CURING OF THE GROUT

The application should be protected from wind, rain, frost and direct sunlight. The curing period is dependent on ambient conditions. The application should be moistened to avoid premature drying in warm, dry weather conditions. Once the grout is ready, cure it under a layer of water (recommended to be kept for at least 3 days).

Continue with this curing method until the final set of the grout (determined at the time at which one cannot penetrate the grout with a pointed trowel). Consider the strength development curve at different temperatures to decide when the formwork can be removed or when the bolts can be stressed.



13. CLEANING TOOLS

Clean all tools and application equipment with water immediately after use. The hardened material may only be removed mechanically.



14. WASTE DISPOSAL

Dispose of unwanted material responsibly through licensed waste disposal contractors, in accordance with local legislation and/or regional authority requirements. (For detailed information refer to the material safety data sheet).



15. CONTINGENCIES: SOLUTION PROPOSALS

Check with Sika Specialists for further details



16. FINAL INSPECTION

HOW TO: IMPROVE CARTRIDGE APPLICATION PERFORMANCE

The ability to dispense multi-component adhesive products in cartridges has become a key driver for their use in the wind industry, especially for on-site repairs.

The apparent simplicity of using multi-component cartridges has also been a major factor in their popularity in the wind market, but there are some key areas to consider for ensuring the best application quality.

All multi-component adhesives require sufficient mixing to ensure that the cured material properties meet specifications. It is therefore important to select the correct mixer diameter and the number of mixing elements to ensure that the material exits the mixer as a homogenous mixed material. This can be checked visually by looking for streaks and marbling in the mixture which would indicate poor mixing.

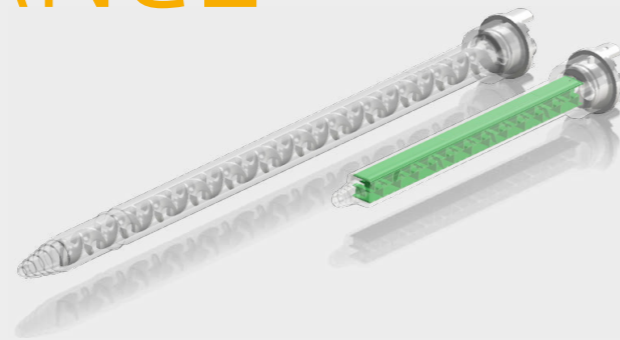

Equivalent sized mixers. Helix mixer (LHS) and Quadro mixer (RHS)

The other main consideration is application temperature as this affects the viscosity of the component materials contained within the cartridge. This, in turn, affects the back pressure and ability of the mixing elements to fully mix the components over the length of the mixer. It is therefore important to evaluate the mixing properties of a particular mixer over the usual application temperature of the adhesive to be certain.

SELECTING YOUR GUN

It is important to choose the correct application gun. As there are specific mixing ratios for different multi-component adhesives, the first priority is to select a gun with the same ratio as you have in your cartridge. For the wind industry these are typically 1:1, 2:1 and 10:1, measured by volume.

There are 3 main ways to power application guns. The decision on which type to choose will invariably come down to availability of the power source.



Pneumatic gun. Image courtesy of Medmix AG.



Battery gun. Image courtesy of Medmix AG.

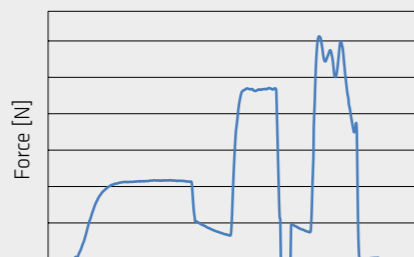

BATTERY AND PNEUMATIC APPLICATION GUNS

The force acting on the piston can be adjusted stepwise to control the flow rate of the material. The very linear force acting on the cartridge pistons greatly improves mixed adhesive consistency. However very high forces should be avoided as this can lead to inconsistent flow rates.



Manual gun. Image courtesy of Medmix AG.

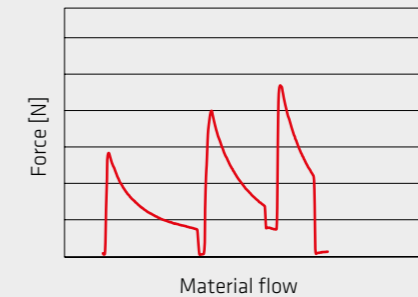

MANUAL APPLICATION GUNS

The force acting on the piston is defined by the gearing within the specific gun and cannot generally be adjusted.

Once the trigger is depressed, the material flow drops as the pressure in the system is released and the force drops to zero. The cycle is then repeated by depressing the trigger again. This drop in the force acting on the cartridge pistons leads to an inconsistent mix and is therefore not recommended for use with Sika's wind products.

GETTING STARTED

The good news is that Sika has already defined the correct mixer for a specific product/cartridge type, so it is important to follow this recommendation.

Once the cartridge is loaded into the application gun, remove the blanking plug and extrude 5-10mm of material out of the cartridge to level both the components. Clean both outlets to avoid cross-contamination and affix the correct static mixer to the end of the cartridge, tightening by hand only. Squeeze the trigger and extrude approximately 2 mixer lengths of material in beads. Visually check for streaks or marbling in the mixed material.

If all looks good, then application can commence.

For application stops shorter than the mixer open time, application can re-start immediately. If the mixer open time is exceeded, a new mixer is then required, and again 2 mixer lengths need to be extruded for a visual mixing check.

Further information is available in the product data sheet and additional product information sheets for each specific material. ■



RELIABLE REPAIR INJECTION

↗ The trend within the wind industry is towards higher capacity turbines. As blades get longer and more complex to manufacture, the number of minor defects such as voids or dis-bonds within the composite structure invariably increases. Over its typical lifetime, a blade may see over 60 million rotational cycles, and any defect left untreated during its manufacture may give rise to stress concentrations leading to cracking and premature failure.

Having a robust and reliable solution to repair these is vital to ensure the longevity of the blades in operation and to reduce the number of field service repairs.





Material selection

In an ideal world, the solution selected to repair voids or dis-bonds would have final properties that are the same as the original blade. However, the properties that make bonding pastes suitable for manufacturing large composite structures, such as long open time, high sag resistance and relatively long thermal curing profiles, are not suited for repair injection where low viscosity and full room temperature curing capability are beneficial or preferred.



The material used should have little or no shrinkage as this will require further remedial work to fully fill the voids. Shrinkage voids within an existing repair cause localized stress concentrations which can also initiate detrimental cracking. This is a well-known disadvantage of existing fast-curing solutions on the market.

It is therefore inevitable that an alternative to the blade bonding adhesive is required for injection bonding and ideally, it should have as similar properties as possible in the other areas. Sika has developed SikaPower®-800, a low-shrinkage epoxy repair injection adhesive that is chemically identical to current blade bonding adhesives. It offers very similar mechanical properties, a higher toughness to resist cracking and can also fully cure without the need for external heating.

KEY FEATURES AND BENEFITS

- Excellent injection properties
- Chemically identical to original blade materials
- Similar mechanical properties
- Low shrinkage
- Improved toughness
- Ambient temperature curing
- No post curing required

Application and curing

INJECTABILITY

SikaPower®-800 has been formulated to offer improved injectability properties compared to current commercially available solutions. This saves time during injection repairs and thus increases customers' production efficiency

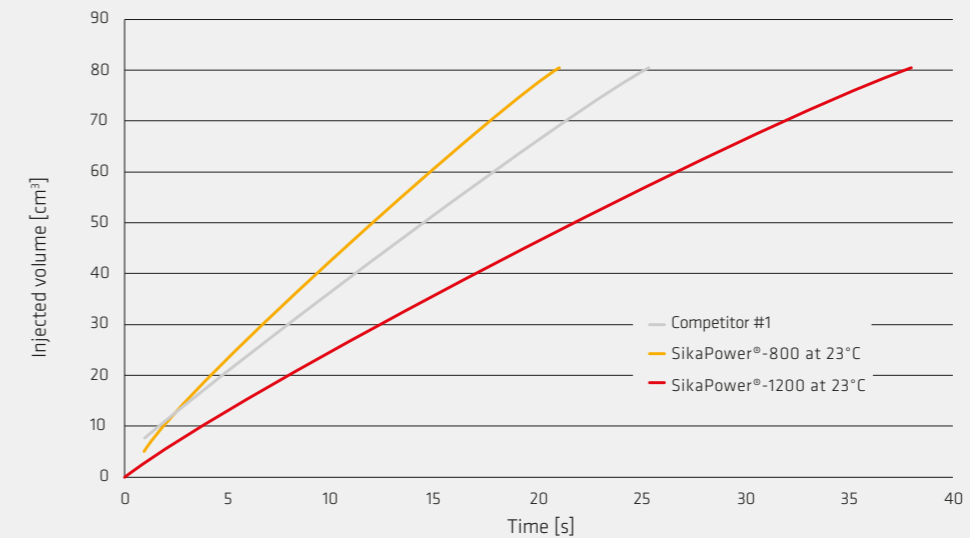

Injection volume vs. time

CURING

It can be very time consuming and expensive to reach the required post-cure temperature during the repair process. The physical mass of the blade acts as a large heat sink drawing heat away from the repair area, increasing the time it takes to reach a minimum level. Field repairs also have the added issue of the prevailing ambient temperature adding to this effect, especially in the colder months.

The optimal solution is to therefore have a material that can fully cure without the need for subsequent post curing. SikaPower®-800 has been developed to reach a handling strength of 1-2 MPa after 3hrs and reaches 95% of final strength after 24hrs.

Subsequent post curing has a limited effect on increasing the mechanical properties and is therefore not necessary.

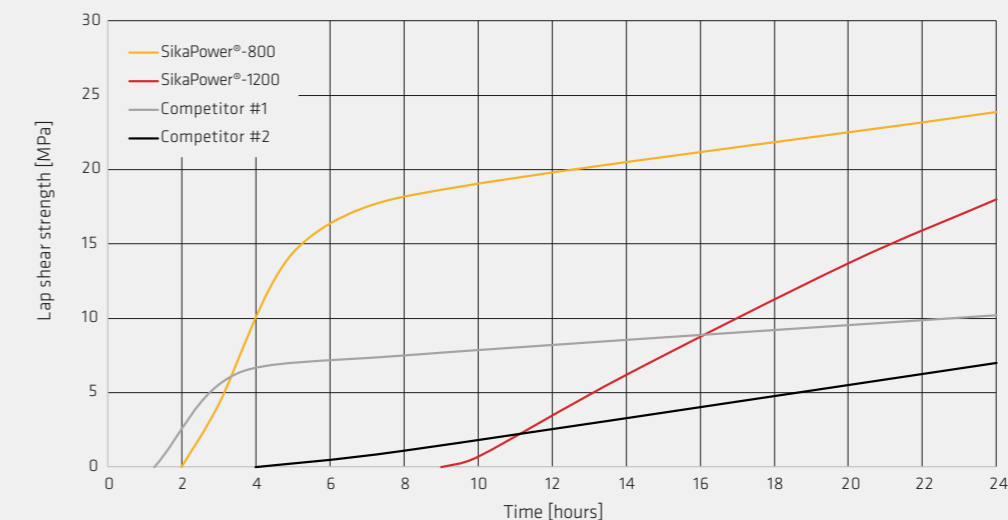

Strength vs. time

BETTER BONDING BY DESIGN

It is important to understand the individual advantages and limitations of any fixation method. Good joint design can then be employed to maximize its advantages while minimizing the limitations to ensure that a joint will last. Adhesive bonding is no different. By following a few basic design principles you can ensure long lasting, durable joints.

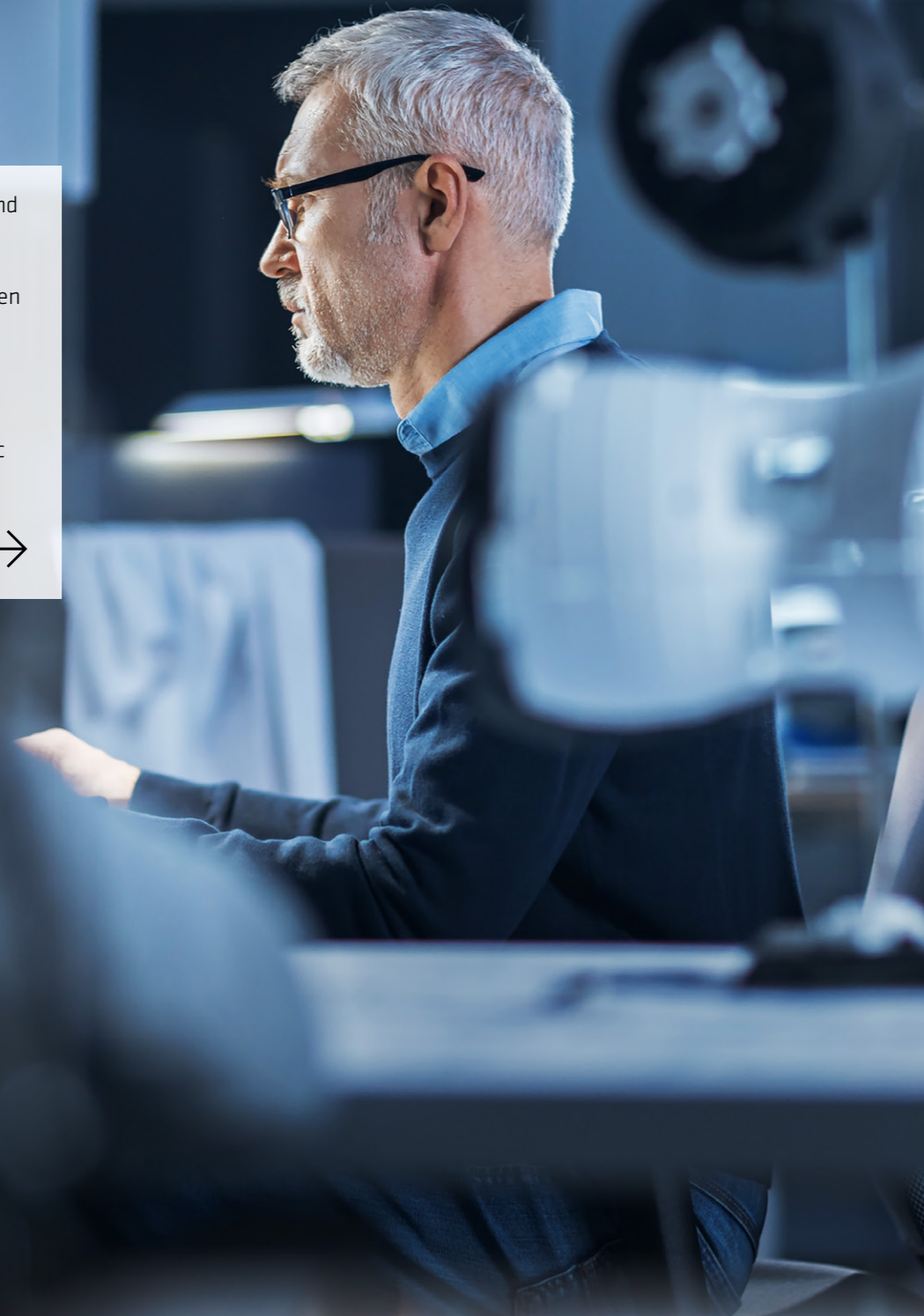

IT BEGINS WITH THE INITIAL DESIGN

Adhesives offer many advantages over other types of fixation, but only if the joints are designed correctly. The joint should be designed to minimize stress concentrations as adhesives work better over larger areas and not on single points or lines. For example, here is how a typical T-joint could be designed when switching from fillet welding to structural bonding, which allows the stress to be distributed over a larger area (shown in orange).

When dimensioning a bonded joint the following factors must be considered:

- Mechanical properties of the adhesive
- Substrate characteristics (type, size, mechanics, surface condition, etc.)
- Geometrical features
- Loading case
- Reduction factors

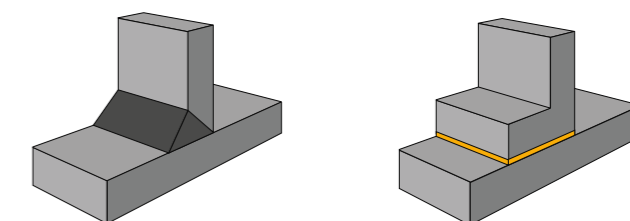

T-joint by fillet welding

T-joint by structural bonding

Figure 1. T-joint design examples for welding and bonding.

BASIC DESIGN PRINCIPLES AND BEST PRACTICES

Adhesives in bonded joints are generally subject to one, or a combination, of the different stress types seen in figure 2. Torsion and bending can cause stresses similar to combinations of these stress types.

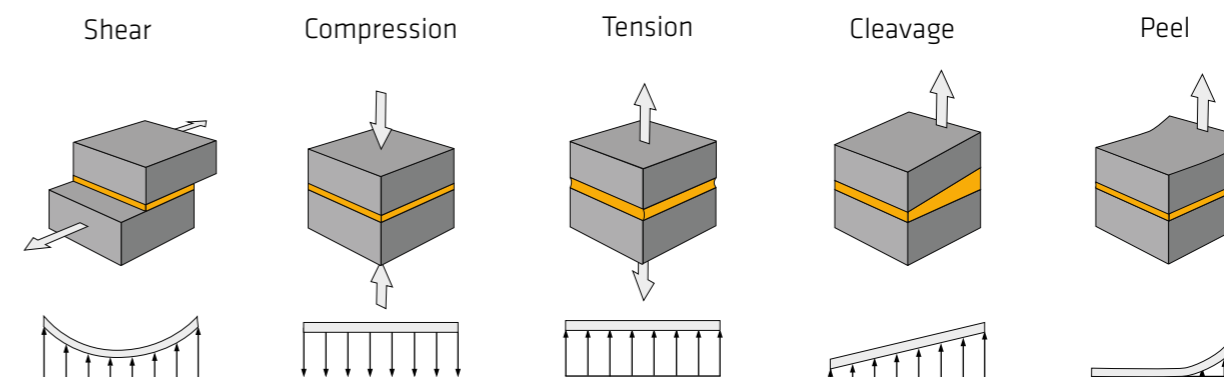

Figure 2. Fundamental types of stresses in bonded joints.

Adhesives are good at resisting shear forces as the stress can be spread relatively evenly over the whole bonded area, so designing to incorporate shear makes good sense. However, shear stress peaks occur at the two ends of the overlap, and these extremities carry the majority of the load. The nature of the stress peaks at the overlap depends on the relative stiffness of the adhesive and the adherends. For a flexible adhesive in shear, the stress is distributed more uniformly giving lower peak stress at the end of the overlap.

Compression and tension loads, applied by stiff substrates, create an even stress distribution in the adhesive layer, which is also a favorable design feature. Compression loads are preferred since the adhesives show typically higher strength when compressed, while tensile loads may lead to peeling or cleavage if the adherends deflect or the applied load is offset to any degree. Peeling and cleavage concentrate high stresses on a single boundary line of the joint leading to premature failure, especially when using rigid adhesives. Joints subjected to peel or cleavage stresses – as well as to bending – should be redesigned for bonding applications.

BEST PRACTICES FOR BONDED JOINT DESIGN

The basic principles for designing bonded joints can be summarized by following the rules illustrated here.

- Avoid peel and cleavage stresses; prefer compression and shear stresses.
- Increase the bond area as much as possible.
- Design the joint so that the stresses are as evenly distributed as possible.

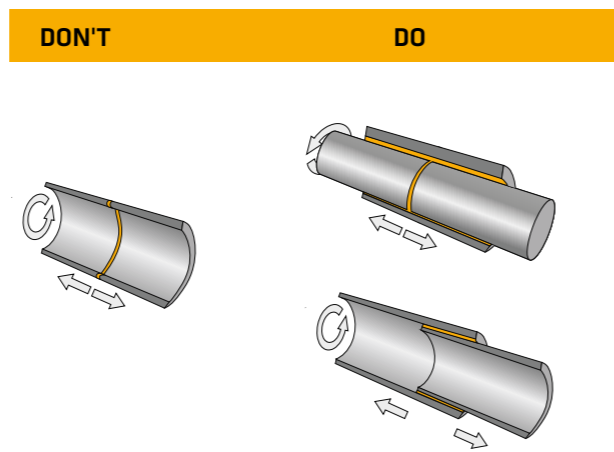
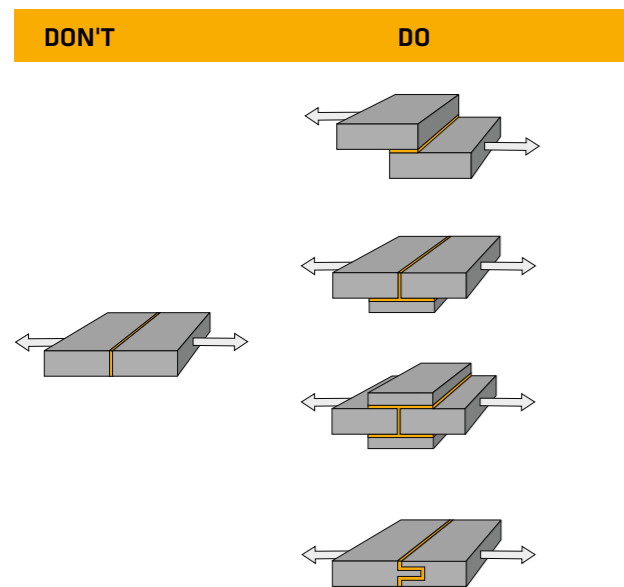
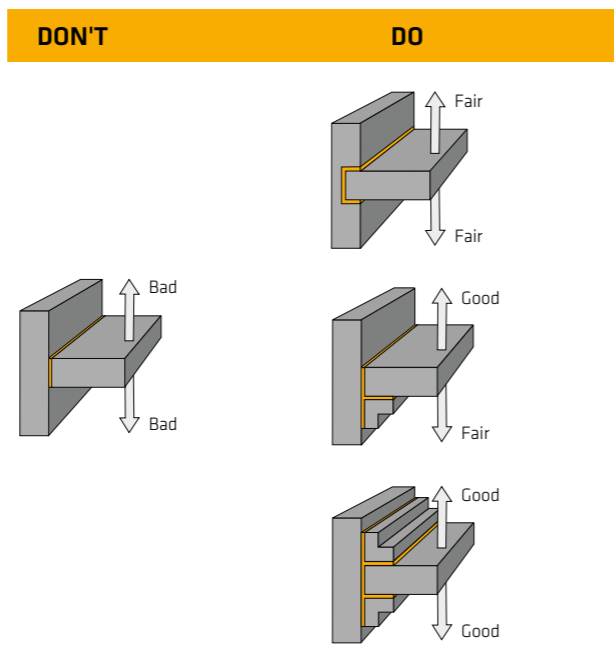

Figure 3. Best practices for bonded joint design.



DIMENSIONING WITH REDUCTION FACTORS

Once a suitable design has been defined, its dimensions can be calculated based on the ability of the adhesive to transfer load throughout its operational life. The external environmental conditions as well as fatigue and creep forces tend to reduce the adhesive's mechanical properties over time and should be allowed for to avoid premature joint failure. In addition, the adhesive thickness and service temperature must be considered for design purposes because they also influence the final material strength. Therefore, joint dimensioning should be based on material data representing the critical scenarios that may occur in service life.

A simplified approach involves using reduction factors (γ) for temperature, thickness, environmental aging, lifetime loads, etc., on the reference or characteristic strength (τ_c), along with a design safety factor (S_d), to calculate a maximum allowable strength (τ_a) using the following formula:

$$\tau_a = \tau_c * \gamma_{temp} * \gamma_{thick} * \gamma_{ageing} * \gamma_{load} \dots / S_d$$

Reference sets of reduction factors for selected Sika products are available in our technical documentation.

THE EMERGENCE OF CONCRETE PRINTING

DIGITALIZATION IN CONSTRUCTION

Traditional reinforced concrete is the most economical method of construction and has been successfully used for decades. Even so, a fundamental change is taking place in the construction industry with the introduction of 3D concrete printing (3DCP) to optimize the building process.

Additive manufacturing or 3D printing is well implemented in the fields of automotive, consumer products, medical and food industries. There has, however, been a slower uptake in the construction industry due to the larger scales required, the complexity of the chemistry and physics of the material and the lack of building standards for 3D printing.

Despite this, there are many examples of digitalized concrete construction with a push coming from 3D concrete entrepreneurs and institutes and a market pull from owners, architects, engineers and contractors able to imagine the design flexibility and potential of this technology. Sika aims to support this passion for 3D concrete printing by offering concrete printing materials and solutions.

COVERING ALL BASES

Sika offers comprehensive Sikacrete® 3D solutions for rapid, precise and inexpensive concrete printing. Drawing on Sika's 100-year history in cement and admixture technology and our expert knowledge in construction materials and solutions, we are well equipped to support you in starting or improving your 3D concrete printing business. Sika also has a wide range of colorings, coatings, protections, sealants, bonding, adhesives, anchoring and much more to add value to your product proposition.

1K

One-component

2K

Two-component

Admixtures

and compatible solutions

SIKA SOLUTIONS AND BENEFITS

Sikacrete®-7100 3D is a 2-component product consisting of a cementitious powder with fibers and a liquid polymer which is combined with water in the mixing station. Additional colors can be added at this stage to enhance the appearance of the finished product. An activator is then added in the print head which provides setting on demand.

Sikacrete®-751 3D and Sikacrete®-752 3D are one-component products which just need to be mixed with water. They are highly thixotropic and accelerated to allow for higher layer stacking to improve output. They are formulated with a small grain size to give a smooth finish but also to reduce pump wear and final shrinkage.

Concrete printing is a new technology to the market and opens huge opportunities for design freedom. It is now starting to be used in the construction industry, but it is still early days for the wind industry. However, opportunities exist in the onsite printing of tower segments or complete foundations, so watch this space.

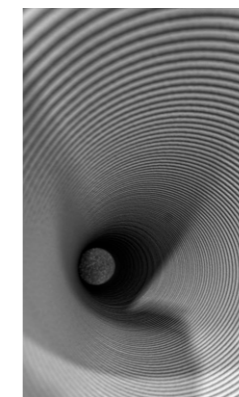

Industry-Ready

- Saves time on choosing, ordering, setting up and testing materials, while allowing you to concentrate on business and sales

Technical Support

- Sika know-how for printing materials, CAD, technical design, operator manuals, training and updates
- Additional network to the construction industry

High Quality

- Small grain size for a smooth finish in light grey or optional colors to enhance your product
- Very high standard of printing

Increased Productivity

- Automated process requires less labor than traditional concrete casting techniques
- No formwork
- Immediate setting means the objects can be moved within a short time after printing
- Long pot life of the mix means the production process can be paused and restarted easily

Add-Ons

- A range of Sika products which can add value to your product proposition

THE POLYURETHANE PARADOX

➤ Polyurethane is one of the world's most widely used synthetic polymers. Besides Sika's well-known adhesives, polyurethane is also used in many other conventional products in our everyday life. From mattresses to shoes, textiles and medical instruments, the use of polyurethane is all-pervasive.

THE CURING PROCESS IN POLYURETHANE PRODUCTS

One-component polyurethane adhesives and sealants cure by reaction with atmospheric moisture. This reaction is based on crosslinking of the pre-polymers through their isocyanate groups. The reaction, also called curing, converts the extruded fluid product into a polyurethane polymer compound with its unique properties. When applying such polyurethane products, users may be exposed to minimal amounts of unreacted monomeric diisocyanates that were used in the production of such pre-polymers.

The same accounts for the reaction of two-component polyurethane products, where isocyanates react with a polyol-containing component to form the final high-performance compound. Typically, all polyurethane-based products follow these types of reactions to form the products which surround us. However, once fully cured, and the diisocyanates have all reacted, the final compounds become completely free of any reactive chemicals.

REACH REGULATION FOR USE OF DIISOCYANATES

The European Union has announced a new REACH (Registration, Evaluation, Authorization and Restriction of Chemicals Regulation) legislation to increase the safety in using products containing more than 0.1% of monomeric diisocyanates. The new law comes into effect on August 24th, 2023. The regulation requires industrial or professional users of products containing more than 0.1% of free monomeric diisocyanates to be trained, with instruction on the risks associated with working with diisocyanates and the corresponding risk-management measures. By following the respective safety measures, polyurethane products continue to be safe to use and will remain available within the market.

SIKA'S EFFORTS TOWARDS USERS' SAFETY

When handling chemicals, it is important to keep the exposure to them as low as possible. Sika, as a leading producer of polyurethane-based sealants and adhesives, takes the health and safety of users of products containing diisocyanate very seriously. As a result, Sika is offering free access to the mandatory training for the upcoming European REACH regulation for the safe use of products containing diisocyanate.

The regulation can impact a majority of polyurethane products available on the market, e.g. adhesives, sealants, coatings, floorings, etc. Products containing more than 0.1% of monomeric diisocyanates can be identified either by checking the relevant Safety Datasheet or the label (note that cured products, in their finished state, no longer contain isocyanates and the restriction does not apply to them).

Sika, as a member of FEICA, the Association of the European Adhesive & Sealant Industry, offers free access to the training via www.safeusediisocyanates.eu by using the Sika code: FEICA_21_C20

All professional users (workers and supervisors) are obliged to perform the training before the deadline in 2023. The web-based training platform contains various sections. With the training selector, you will be guided to the correct training depending on products and applications.



Scan the QR code to access the training homepage



ISOCYANATE-FREE Sikaflex®-5XX & -95X SERIES

Sika's Sikaflex® range of elastic polyurethane adhesives is partially affected by the upcoming regulation. All products from the Sikaflex®-2xx series contain more than 0.1% diisocyanate in an uncured state. However, you can benefit from Sika's isocyanate-free solutions for one- and two-component Sikaflex® products. The silane terminated polymer (STP) range of adhesives and sealants from the Sikaflex®-5xx and -95x series are free of isocyanates and thus do not require the upcoming REACH safety training for safe use.

CLOSING THE CONCRETE CIRCLE

reCO₂VER and concrete recycling

➤ Sika has succeeded in developing a highly efficient process to separate and reuse components of demolished concrete and increase the recycled aggregates' quality. The old concrete is broken down into individual parts – aggregates, sand, and fine powdered material – in a simple process which also binds a significant amount of CO₂.

CAN DEMOLISHED CONCRETE RECYCLING BE MORE SUSTAINABLE?

Yes! This innovation, with the brand name reCO₂ver, will make a significant contribution towards reducing the ecological footprint of the construction industry, by offering the following benefits:

- Cleaning of concrete waste from cement stone
- Recovers raw materials in reusable quality
- Sequestration of CO₂ by carbonation of cement stone powder
- Carbonated fine powder usable in composite binders
- IP protected
- Industrial scale pilot plant for final proof of concept

Why is smart concrete recycling important?



CURRENT SITUATION AND CHALLENGE:

Large volumes of concrete demolition waste are generated worldwide every year. The vast majority of it ends up in landfills. This waste could instead be recycled. Recycling this material is particularly crucial in dense urban areas, as this is where most old concrete accumulates.

WHAT IS WRONG WITH CURRENT RECYCLED CONCRETE?

State-of-the-art recycling of construction and concrete demolition waste has up to now only achieved unsatisfying performance levels:

- Return rates of secondary raw material for concrete production are below 60%, and the application field is limited to low-grade concrete.
- In particular, because of the low quality of available secondary aggregates, their exchange rate for primary material is limited to about 30% – a very unsatisfying level at which desired quality of concrete has to be ensured through the excess amount of cement and chemical admixtures.
- Overall, state-of-the-art recycling has resulted in down cycling, leading to poor quality of secondary material, which can contribute towards global warming.

CONCRETE RECYCLING OPTIMIZATION WITH SIKA'S INNOVATIVE reCO₂ver PROCESS

Sika's novel recycling technology is based on exploiting synergy from a chemo-mechanical treatment of concrete demolition waste. It involves superficial carbonation of the cementitious matrix that is softened and removed upon attrition. With that, freshly exposed surfaces are obtained, able to further carbonate until aggregates free from cementitious material are obtained. In that way, concrete/mortar demolition waste can be separated into "secondary aggregates" for recycling at a quality level of primary material and a powdery material utilizable as secondary raw materials in a broad application spectrum.

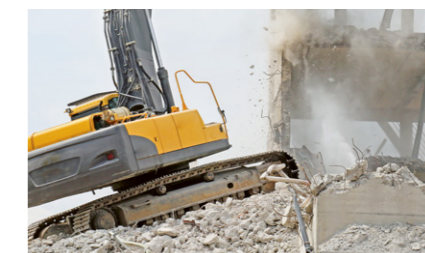

The recycling process elaborated by Sika is tackling several issues related to the state-of-the-art recycling of construction demolition waste. In a relatively simple and efficient process, clean aggregates can be extracted from concrete waste. Moreover, the process is sequestering about 50 kg of CO₂ per ton of crushed concrete demolition waste.

Comparative testing of the Sika reCO₂ver process has demonstrated that new concrete containing recycled content performs similarly to an all-new product. Thanks to additionally developed chemical additives, other process optimizations can be achieved, such as the flexibility to tailor specific concrete functionalities.

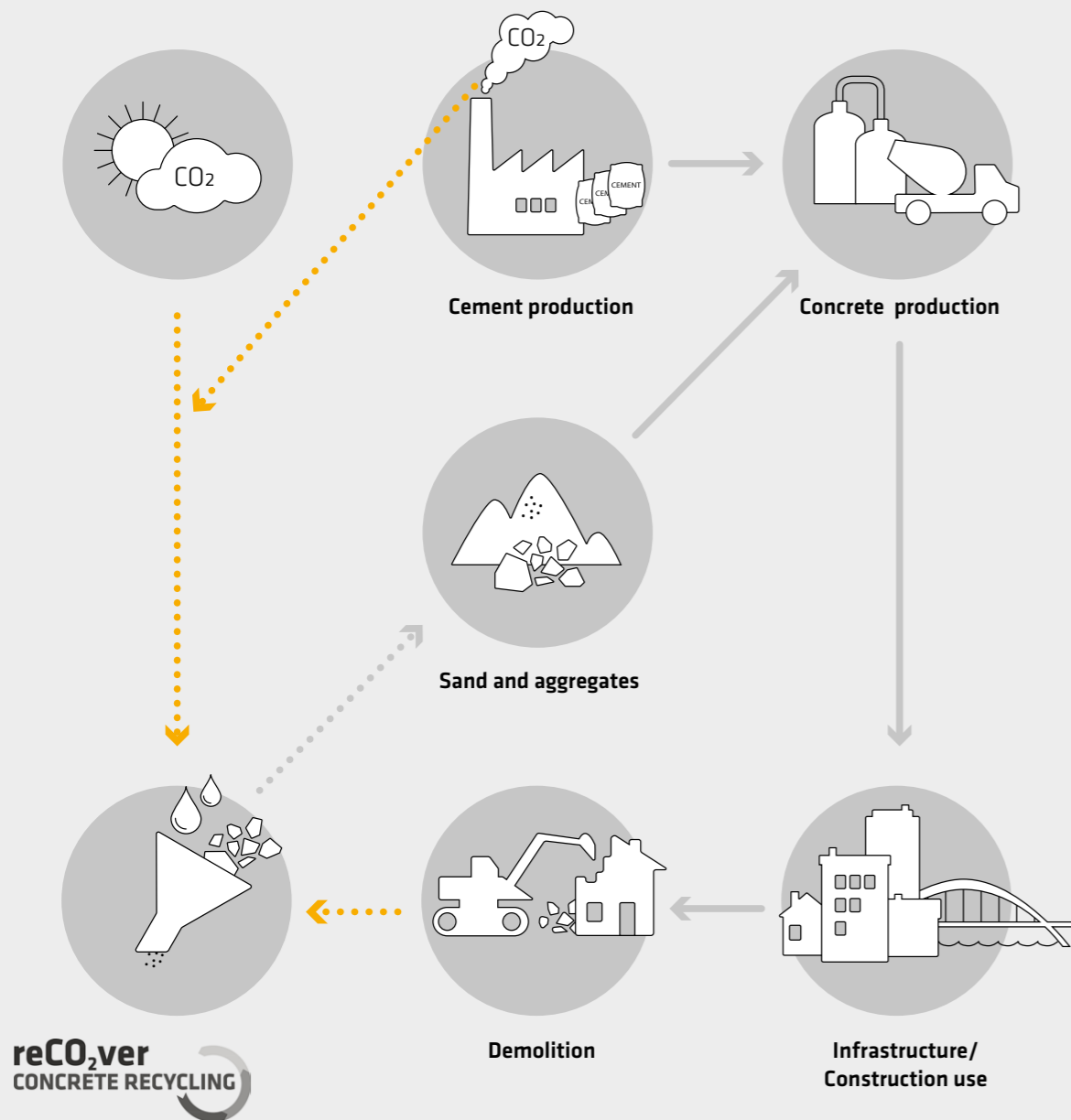

Some of the benefits include: reduction of water by up to 40%, reduction of cement content by 25%

MILESTONE IN CONCRETE RECYCLING

With the new process, demolished concrete can be completely recycled and saved from landfill. So far, attempts to recycle old concrete have led to rather low recycling rates, and only 30% of primary material can be substituted by these recycled materials in structural concrete. The Sika innovation will produce high-performance concrete while sequestering a significant amount of CO₂.

THE BENEFITS OFFERED BY reCO₂ver INCLUDE:

- Circular economy of concrete
- Saving natural resources
- Use of concrete waste for CO₂ sequestration
- Additional reduction of CO₂ emissions:
 - By reduction of cement requirement in recycled concrete
 - By partial replacement of clinker with generated fine powder

SCALE OF THE PROBLEM

The wind industry is still relatively young, with the first utility-scale wind turbines being installed in 2000. With a design life of 25 years, we have yet to enter the product lifecycle decommissioning phase for the first turbines installed.

The conversation on wind blade recyclability is already gaining traction and new recyclable resin systems for blades are starting to be announced. This will be great news for 2050 and beyond.

However, little is being discussed about the recyclability and circularity of concrete materials used within the wind industry. Since 2000 there has been an exponential increase in the number of turbines installed, and by 2025 it is estimated that there will be over 400,000 turbines needing to be recycled.

Sika has already successfully developed processes for recycling concrete into new valuable raw materials for complete circularity within the construction market, and this is something that can now be easily applied to the wind industry to support the overall recyclability percentage for turbines. With a viable materials recyclability solution for concrete now available, concrete towers could become a much more attractive option compared to steel in the future. ■

"In the five largest EU countries alone, roughly 300 million tons of old concrete are generated every year. With complete recycling of these materials, up to 15 million tons of CO₂ emissions could be captured. We are convinced that our new process has the potential to benefit both our customers and the environment."

Thomas Hasler, Chief Executive Officer

BEYOND WELDING

New opportunities
in adhesive bonding

➤ Welding is a well-known, highly established joining technique that allows for the immediate fixation of metal parts. Due to a lack of knowledge about alternative joining technologies, many traditional manufacturing industries still heavily rely on welding as their main joining technology. This preference for welding holds true for wind turbine tower and platform manufacturers as well.





PROBLEMS CAUSED BY WELDING

While welding may be preferred for some selected structural applications, it does have its limitations. Dissimilar materials are difficult or impossible to join, welding requires protective coatings to be removed prior to welding and reinstated afterwards, the process can distort small parts due to excessive heat, and welding requires highly skilled operators to achieve the best results.

According to the American Welding Society there will be a shortage of 400,000 welders by 2024.

The urgency of the situation makes it imperative to rethink these processes very soon. At the same time, it presents an opportunity for re-design and innovation.

Wind turbine towers and offshore platforms are subjected to demanding environments such as rain erosion, salt spray and extreme temperatures, so protective coatings are specified on all metallic parts. Post-coating processing such as the welding of attachment parts (cable trays, ladders, etc.) requires removing these protective layers by abrasion to get back to the bare metal. The integrity of the coating is compromised and must be reinstated after welding. This is not only time consuming but can also cause further complications such as corrosion if not applied correctly

THE CASE FOR BONDING SOLUTIONS

With the right joint design, structural adhesives are more than capable of providing durable fixation for many structural applications. They can eliminate the labor time and costs associated with metal preparation and finishing operations and improve the overall manufacturing process. Let's explore some of the advantages in detail.

WHY BONDING?

Design freedom and ease of use are just some of the benefits that structural adhesives bring to industrial platform assembly and tower manufacturing. Sika features a diverse range of structural adhesives designed to replace welds, rivets and mechanical fasteners while improving fastening strength and durability. We offer innovative solutions that can be used for a wide array of structural applications.

Using structural adhesives helps achieve a more even stress distribution, leading to better long-term properties such as durability and fatigue. In some cases, adhesives also allow for a reduction of the metal thickness and thus a reduction of weight and costs. Adhesives also enable users to make significant gains in productivity. Secondary process steps, such as sanding and polishing processes or re-application of coatings after welding, can be reduced or eliminated.

As an example, Sika evaluated the potential of using Sika's adhesives instead of welding to fix the brackets used to mount the cable trays on offshore platforms. With more than 200 installed brackets per turbine, this example shows the strong potential for bonding solutions compared to traditional welding. ■



Sika offers an extensive portfolio of adhesive solutions to join metal to metal or other materials, from 1-component heat-curing epoxy adhesives to two-component structural adhesives based on acrylates, epoxy and polyurethane. Sika's global expertise, combined with local technical service, helps industrial manufacturers find the best structural adhesive for their challenging applications.

Productivity increase of up to 88%

Welding process	Adhesive process
10 minutes Grinding and cleaning	40 minutes Pretreatment & bonding
10 minutes Welding/Stud welding	20 minutes Curing to handling strength
Up to 8 hours* (Priming), base coat, top coat + individual curing for further handling	60 minutes
8h 20min	

**Based on current market systems*

Process differences between classical welding and advanced adhesive technology

“By eliminating the removal and re-application of protective coatings, we are able to offer a productivity increase of up to 88%.”

Simon Leu, Market Field Manager, Wind Energy, Sika AG

PRODUCT NEWS



SikaBiresin®-910 BLADE REPAIR

SikaBiresin®-910 is a new hand-laminating resin system with two hardener speeds for fast, reliable composite repairs.

The product can be applied from 5 to 35°C and has excellent fiber-wetting and non-draining properties. It requires no gel time delay before heating and offers fast heat curing with high Tg values.



SikaForce®-710 L30

This two-component polyurethane has been designed for precise in-situ re-balancing of wind blades after major repairs. The product is supplied in 415 ml 2:1 side-by-side cartridges for direct injection through small drill holes. This ensures quick, clean and easy application and significantly reduces waste due to overspill. The product is free from any conductive fillers to avoid affecting the lightning protection system.



SikaPower®-800

Developed as a low viscosity epoxy repair injection adhesive for composite structures, SikaPower®-800 is available in 400ml 2:1 side-by-side cartridges. Offering excellent injection and mechanical properties, the product is fast curing, reaching >1MPa handling strength in 3hrs. It cures fully at room temperature to high Tg levels without heating.

SikaGrout®-3350: THE ULTIMATE ULTRA HIGH-PRECISION ONSHORE WIND GROUT

Completing Sika's onshore wind grout range SikaGrout®-3350 allows us to meet the requirements for the most demanding projects. It has the following main advantages:

- Ultra-high compression strength, equivalent to values of C120
- High build up. Layers between 20-500mm.
- No cracks.
- High fatigue resistance, equivalent to concrete class C130.

SikaGrout®-3320: PERFORMANCE MEETS SUSTAINABILITY

The new optimized high-precision onshore wind grout with reduced carbon footprint. Among Sika's key pillars are our ambitions to enhance customer value and reduce environmental impact. Our goal is to provide the most innovative and effective solutions with reduced environmental impacts to fulfill all the technical needs of the project. And at the same time protect and respect our commitment of keeping our impact to the environment as low as possible.

Years of research and practical experience have enabled Sika to develop a new wind grouting solution to fill gaps under turbine bases with a reduced carbon footprint. Sika customer advice and support is second to none, from concept to successful completion on site.



Designed for our customers

- Turbine manufacturers: meets most demanding design specifications
- Contractors: free flowing grout that will not crack after placement
- Designers: ultra-high strength, fatigue certified onshore wind grout



More performance

- High build up
- High final strength development

More sustainable

- Reduced carbon footprint
- Meets LEED v4 requirements





CONTACT US FOR MORE INFORMATION



www.sika.com/wind

Sika AG, Switzerland, is a globally active specialty chemicals company. Sika supplies the building and construction industry as well as manufacturing industries (automotive, bus, truck, rail, solar and wind power plants, facades). Sika is a leader in processing materials used in sealing, bonding, damping, reinforcing and protecting loadbearing structures. Sika's product lines feature high quality concrete admixtures, specialty mortars, sealants and adhesives, damping and reinforcing materials, structural strengthening systems, industrial flooring as well as roofing and waterproofing systems.



SIKA SERVICES AG
Tueffenwies 16
CH-8048 Zurich
Switzerland

Contact
Phone +41 58 436 40 40
Fax +41 58 436 55 30
www.sika.com/wind

BUILDING TRUST

