



SIKA PASSIVE FIRE PROTECTION HANDBOOK



PROFESSIONAL
FIRE PROTECTION

BUILDING TRUST





SIKA SOLUTIONS TAME THE ELEMENT

Fire has been a fascinating element for thousands of years and many achievements in the history of mankind were only possible with its help.

As much as controlled fire has been driving success and wealth as badly it can hurt us – when out of control – and destroy achievements of decades within minutes. Therefore it is in everybody's interest not to lose control over this powerful and elementary force.

Sika provides comprehensive solutions where fire resistant construction is required such as commercial, public and residential buildings, steel structures and others. Fire resistant sealants, fillers and backing materials for linear seals as well as solutions for penetration seals enable safer buildings and infrastructure to be built. Our products comply with the latest relevant standards and can be used for a wide range of fire protection uses in linear seals, cavity barriers and penetration seals.

PREFACE

The testing and classification of 'resistance to fire' are quite rightly, highly regulated processes that must follow very strict rules and standards. This in turn means that fire resistance test- and classification reports e.g. testing and classification in accordance with EN 13501-2 and/or EAD/ETA, can often become very long documents which are extremely difficult to read and understand – even for people familiar with passive fire protection.

In order to assist with this understanding, and as part of Sika's customer service for the fire protection sector, we have produced this helpful tool to our customers making their lives easier when using our products and dealing with such voluminous testing and classifications.

In this Sika handbook the official results are “translated” into a more easily read and understood language, with all of the general rules applied and clearly stating the limitations of each application. An important part of this are easily understood illustrations of each of these applications. The illustrations only refer to one possible application – e.g. where a picture shows penetration seals for flexible walls, the same layout also applies to rigid walls. Furthermore some of the illustrations do not show all details – like insulation material in walls.

This document is designed as a useful addition, but not as a replacement to the respective third-party testing and classification reports (e.g. ETAs), which remain the only legally binding documents. If there is any confusion or seemingly contradictory information, then the official test- and/or classification reports must be followed.

VERSION 1.0 UK

07/2020, based on EN 1366-3, EN 1366-4

CONTENTS

Preface	4
Contents	5
Introduction	7
Reaction to fire, resistance to fire	7
Compartmentation	9
Linear seals, cavity barriers and penetration seals	10
Intumescence and intumescent materials	12
Linear seals, field of application	13
Flexible walls, rigid walls	14
EN 13501-2: classification for linear seals	15
Movement joints, non-movement joints	15
Linings and insulation	16
Insulated and uninsulated pipes	17
Pipe diameter, pipe wall thickness	18
Penetration services support	19
Pipe and insulation material	20
Combining multiple services in one aperture	20
Selection guide and solutions to linear seals	22
Product overview Linear Seals	23
Selection guide and solutions to penetration seals	34
Product overview Penetration Seals	35
Insulated metal pipes in walls, large apertures	36
Uninsulated metal pipes in walls, large apertures	44
Plastic and MLC pipes in walls, large apertures	48
Cables, cable trays and conduits in walls, large apertures	54
Insulated metal pipes in walls, small apertures	60
Uninsulated metal pipes in walls, small apertures	64
Plastic and MLC pipes in walls, small apertures	68
Cables, cable trays and conduits in walls, small apertures	74
Uninsulated metal pipes in floors, large apertures	76
Plastic and MLC pipes in floors, large apertures	80
Cables, cable trays and conduits in floors, large apertures	86
Insulated metal pipes in floors, small apertures	90
Plastic and MLC pipes in floors, small apertures	92





INTRODUCTION

This chapter is a technical introduction to the topic of passive fire protection explaining most relevant terms and definitions. Furthermore it shall be a helpful tool for a better understanding of rules defined in some of the relevant test- or classification standards like EN 1366-3, EN 1366-4 or EN 13501-2. Applying these rules to tested layouts will allow to cover the most possible applications on site without compromising on safety.

REACTION TO FIRE, RESISTANCE TO FIRE

“Fire testing” can be a very complex topic – the differences between ‘reaction to fire’ and ‘resistance to fire’ can frequently cause some confusion, but can be clarified as follows:

Reaction to fire describes how a material contributes to the development and spread of a fire. Typically reaction to fire is determined for a single material or product such as a wall

covering or joint sealant, and not for a system or section such as a wall including the linear joints and any penetrations. In Europe reaction to fire is now classified according to European Standard EN 13501-1, which is gradually replacing older national standards such as the German DIN 4102.

Euro class	Requirement	Examples of materials
A1	No contribution to fire	Stone, concrete, glass, most metals
A2	Insignificant contribution to fire	Similar to A1 including small amounts of organic compounds
B	No spread of fire and very limited contribution to fire	Gypsum boards with very thin surface covering, fire rated sealants
C	Very limited spread of fire	Gypsum boards with thicker surface coverings
D	Limited spread of fire	Wood & wooden products (depending on size)
E	Acceptable reaction to fire in case of a very small flame	Many plastic products and materials
F	Not passing requirements for classes A1-E	Other materials than classes A1-E



Resistance to fire describes the ability of a building element to prevent the passage of heat and flames from one side to another. Typically such building elements are walls or floors including any joints and penetrations, windows and doors etc. This means that not only a specific material or product, but an entire system or building section has to be tested.

There are many different national and international test standards and classification schemes for fire resistance, however most of them follow the same principle: The building element or component for testing, including all of the service penetrations, joints, doors, windows and the joint sealant in and around them, is fixed into a test frame which is then attached to a test furnace. The side facing towards the furnace is known as the exposed or fire side, whilst the outer side is the unexposed or non-fire side. The furnace temperature is raised according to a defined curve reaching 945°C after 60 minutes and 1,153°C after 240 minutes. Two parameters are relevant for most fire resistance tests: Integrity and Insulation.

E - Integrity

Integrity (E) is a building element's capability – when exposed to fire on one side – to prevent the passage of flames and hot gases to the unexposed side.



I - Insulation

Insulation (I) is a building element's capability to maintain its thermal insulation function when exposed to fire on one side. Most standards allow a maximum of 180°C temperature rise on the unexposed side.

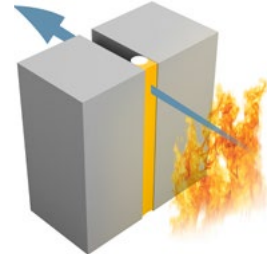

Standard	Description, scope	Remark
EN 1366-3	Test standard for penetration seals	Most relevant standards for resistance to fire testing. Also referred to in EAD and partly AS 1530.4
EN 1366-4	Test standard for linear joint seals	
EN 13501-2	Classification standard for linear joint seals and service penetration seals	Leading to EI classes. Relevant for EN 1366 and EAD
BS 476-20	Test standard for linear joint seals and service penetration seals	British standard; superseded by EN 1366/EN 13501 but still used in some regions
EAD 350454-00-1104	Fire stopping and fire sealing products – penetration seals	Superseded ETAG 026. Leading to CE marking and DoP. Fire resistance tested acc. EN 1366
EAD 350141-00-1106	Fire stopping and fire sealing products – linear joints and gap seals	
UL	Certification scheme for product safety based in the US	Different test methods and requirements for different regions (e.g. UL EU and UL US/UL C)
AS 1530.4	Test and classification for linear joint seals and service penetrations	Australian standard, technically very similar to EN 1366
Certifire	Certification scheme for fire protection products	Relevant in the Middle East

COMPARTMENTATION

Main goal of passive fire protection is not to extinguish fire but rather to prevent the spread of fire and contain it in defined compartments to minimize damage and – even more important – to allow people in other compartments to evacuate safely.

Sika products and solutions presented in this document are designed to maintain separation function of walls and floors even when penetrated by pipes, cables or linear seals.

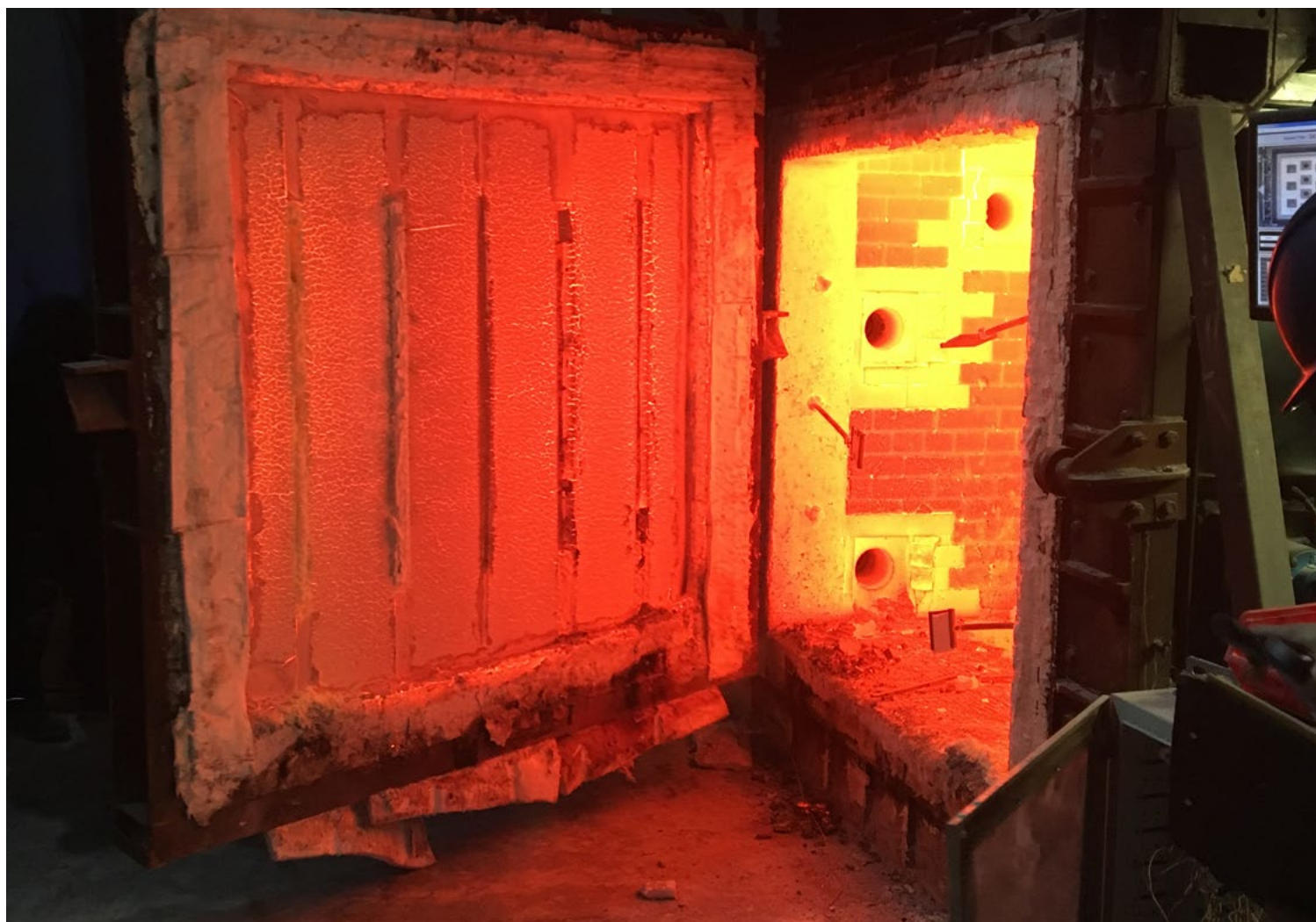

Furnace with vertical linear seals after resistance to fire test acc. EN 1366-4.

LINEAR SEALS, CAVITY BARRIERS AND PENETRATION SEALS

Passive fire protection applications for compartmentations can be divided into the following three main groups:

- Linear joint seals
- Cavity barriers
- Penetration seals

Linear joint seals are passive fire protection systems designed to maintain the required building fire resistance across a separating element plus, if and where relevant, to accommodate a defined degree of movement. Linear joint seals can be found in walls, floors and in so called head of wall applications – joints between wall and ceiling or wall and floor.

A fire resistant linear joint seal can be achieved by different approaches:

- The most common way is to use a fire-resistant joint sealant in combination with a standard PE backing rod. In this case only the sealant is usually required to provide fire resistance while the backer rod is considered as sacrificial.
- An alternative approach is to use a fire-resistant backer rod – typically based on an inorganic fire resistant material like mineral wool – and combine it with a standard joint sealant. In this case the fire resistance of the linear seal is provided by the backer rod and the joint sealant is used to accommodate limited movement, ensure water tightness and provide mechanical protection.
- The 3rd option is to seal the joint with a fire-resistant expanding foam. This system is only recommended where the joints have very limited movement and are not exposed to water, UV radiation or mechanical impact.



PE backer rod and fire resistant sealant



Fire resistant expansion foam



Fire resistant backer rod and standard joint sealant



The following parameters have an influence on the fire resistance of a building element and hence of its classification. Therefore it is crucial to know all relevant details to select the right product.

- 1 Types of involved building material e.g. concrete/steel
- 2 Element orientation horizontal (floor) or vertical (wall)
- 3 Element thickness
- 4 Joint dimension (width, depth)
- 5 Joint configuration: Single seal exposed/unexposed, double seal
- 6 Expected joint movement

Cavity barriers are passive fire protection systems similar to linear (floor-) seals but wider than standard joints in most cases. Cavity barriers typically can be found between floor slabs and curtain wall facades or in wide gaps within a building. Such cavity barriers are designed to avoid the spread of fire from one floor to the other which is one of the major threats when highrise buildings catch fire.

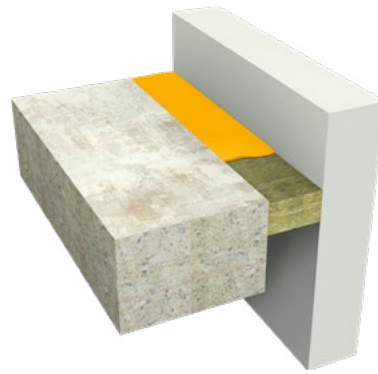

Service penetration seals are passive fire protection systems designed to maintain the fire resistance of a building element or section – wall or floor – where services such as cables, cable trays, pipes or ventilation ducts pass through them.

The vast number of different building materials and different services and the types of penetrations that can be required, leads to a wide variety of different solutions for sealing around these service penetrations. The result is that for most of these penetration sealing applications, several alternative solutions, with different systems and products can be used – if the combination has been tested.



One of the challenges with sealing around penetrations is that certain services (e.g. combustible pipes) will melt in the event of a fire, which results in even larger apertures that must be closed immediately. For this type of application, expanding intumescent materials are usually a very effective solution.



INTUMESCENCE AND INTUMESCENT MATERIALS

Many passive fire protection products are claimed to be intumescent – what does this mean and when can a product be classed as intumescent?

An intumescent is a substance that swells as a result of heat exposure, thus increasing in volume and decreasing in density. Intumescent materials used in fire protection will increase their volume significantly under the influence of heat (approximately at 200°C). This physical process is one of the main principles for passive fire protection products: Intumescent sealants are able to close gaps in and around service penetration seals very quickly in the event that a fire occurs.

These are particularly useful for sealing around any combustible service pipes – which can melt and create larger openings in the building floors and walls – an important role in passive fire protection. However, not all passive fire protection products

are intumescent; for instance flexible silicone joint sealants, acrylic sealants and some coated insulation boards are used for passive fire protection based on different chemical and/or physical principles.

Unfortunately at this time there is no clear definition of how much a material or product has to expand under heat in order to be classed as intumescent. This means that building owners and their professional construction team must take steps to check and confirm that the intumescent materials, systems and products selected and used, will perform and that their volume will expand sufficiently to seal the dimensions of any openings and gaps that could be created during a fire.

Cautionary note: there are some products on the market with less than a 30% volume increase, which are being marketed as being intumescent – Buyer beware!

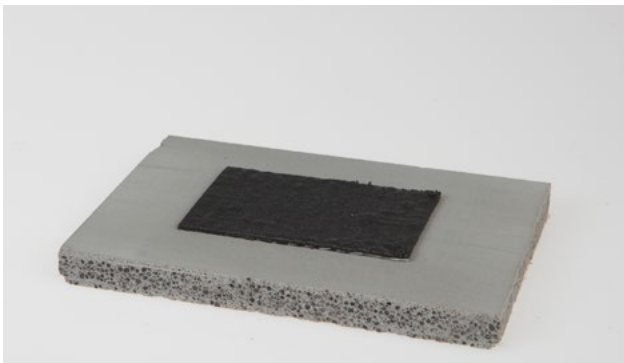

Highly intumescent, fire resistance wrap before (top) and after (bottom) exposure to heat.



LINEAR SEALS, FIELD OF APPLICATION

EN 13501-2 defines in which situations a tested linear seal orientation can be applied to other orientations in practical use. The tables below show a simplified version of these definitions (field of direct application).

In practice this means that vertical joints in walls (B) and horizontal joints in walls (C) are only covered if this specific orientation has been tested, whilst joints between ceilings and walls (D, known as heads of walls) are covered by the testing of seals for joints in floors (A).

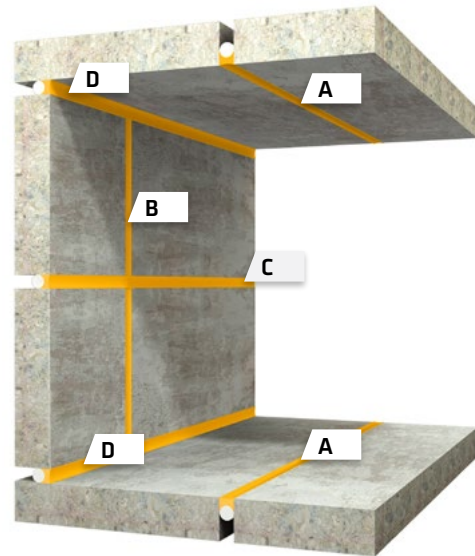

A	Joint in a horizontal test arrangement (floor)
B	Vertical joint in a vertical test arrangement (wall)
C	Horizontal joint in a vertical test arrangement (wall)
D	Horizontal wall joint abutting a floor, ceiling or roof (head of wall)

Tested orientation	Covered application(s)
A	A, D
B	B
C	C



FLEXIBLE WALLS, RIGID WALLS

In principle each type of structural element (walls or floors) will lead to a different fire resistance classification and consequently these have to be tested separately. For simplification EN 1363-1 defines two generic classes of walls; testing using one of these will cover a wider range of substrates than just the one tested. Thanks to this rule resources can be saved without compromising on safety.

- Flexible wall substrates are lightweight gypsumboard faced steel or timber stud wall partitions made from defined materials and dimensions.
- Rigid wall substrates consist of aerated concrete blocks produced with a consistent density of approx. 650 kg/m^3 .

Tests performed with these flexible wall substrates are suitable to cover all flexible walls of the same composition and the same or higher thickness, as well as rigid walls of the same or higher thickness. Tests performed on the rigid wall substrates are suitable to cover all rigid walls of the tested or higher thicknesses and of the tested or higher material densities (e.g. precast concrete instead of aerated concrete).

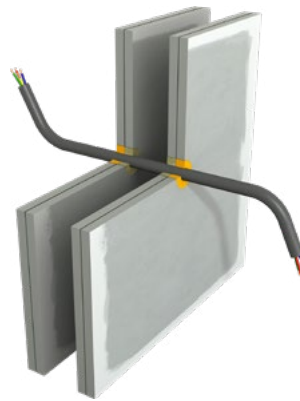

Flexible wall



Rigid wall



EN 13501-2: CLASSIFICATION FOR LINEAR SEALS

EN 13501-2 is the European classification standard for fire resistance of many building elements including linear seals and penetrations.

The classification for linear seals provides information on 5 variable parameters, some of which are well known, whilst others are used less frequently. The following chart gives an overview of this linear seal classification system including all of the available options.

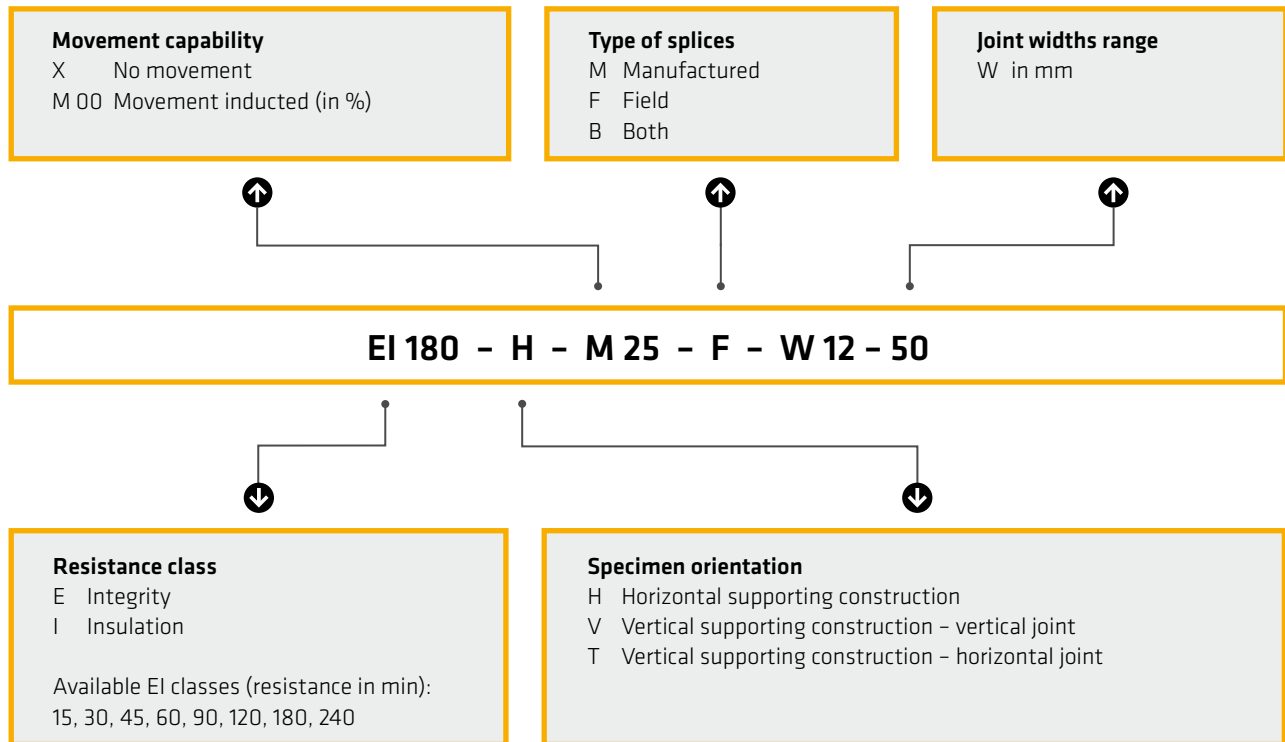

MOVEMENT JOINTS, NON-MOVEMENT JOINTS

You may be asked the question: "Is your fire resistant joint seal able to accommodate movement?" Be careful! - It is not enough to use an elastic joint sealant with the required movement capability (e.g. according to ISO 11600 or ASTM C 920); because also fire resistance tests (e.g. according to EN 1366-4) may be required to be performed under forced movement.

To do so the joint width is mechanically increased by the required amount (e.g. 25%) before the fire resistance test and kept at this position for the duration of the test. From the respective product's EN 13501-2 classification you can see what degree of movement a product was tested with:

EI 120 - V - X - F - W 0-30

Joint classification without movement (X)

EI 120 - V - M 25 - F - W 0-30

Joint classification with 25% movement (M 25)

According to EAD 350141-00-1106 (formerly known as ETAG 026) linear seals tested without movement can accommodate a maximum of $\leq 7.5\%$ movement, for such joints the term non-movement joints or static joints is used. Internal non-structural wall and floor jointing applications (e.g. construction, connection, daywork and isolation joints) typically do not call for more than of $\leq 7.5\%$ movement capability.

LININGS AND INSULATION

Apertures in flexible walls (walls made from metal or timber studs lined with gypsum boards) can be either lined or unlined. A lining is a frame built into the aperture and hence separating the aperture from the inner part of the flexible wall. Mostly such frames or linings are made from the same gypsum boards which are used on the walls.

Generally, a lined aperture leads to better resistance to fire than an unlined and consequently test data obtained from an unlined aperture also covers lined apertures, but not vice-versa. Therefore many of Sika's penetration seals for flexible walls are tested in unlined situations.

An unlined aperture in an insulated flexible wall covers lined apertures of the same size in uninsulated flexible walls.

Flexible walls consist of one or several layers of gypsum boards mounted to both sides of a metal or timber stud. The space between the gypsum boards may be left empty, or filled with insulation material (stone wool, glass wool or similar). The presence of an insulation material improves the resistance to fire performance of the tested system, and consequently test data obtained from uninsulated flexible walls covers insulated walls, but not vice-versa.

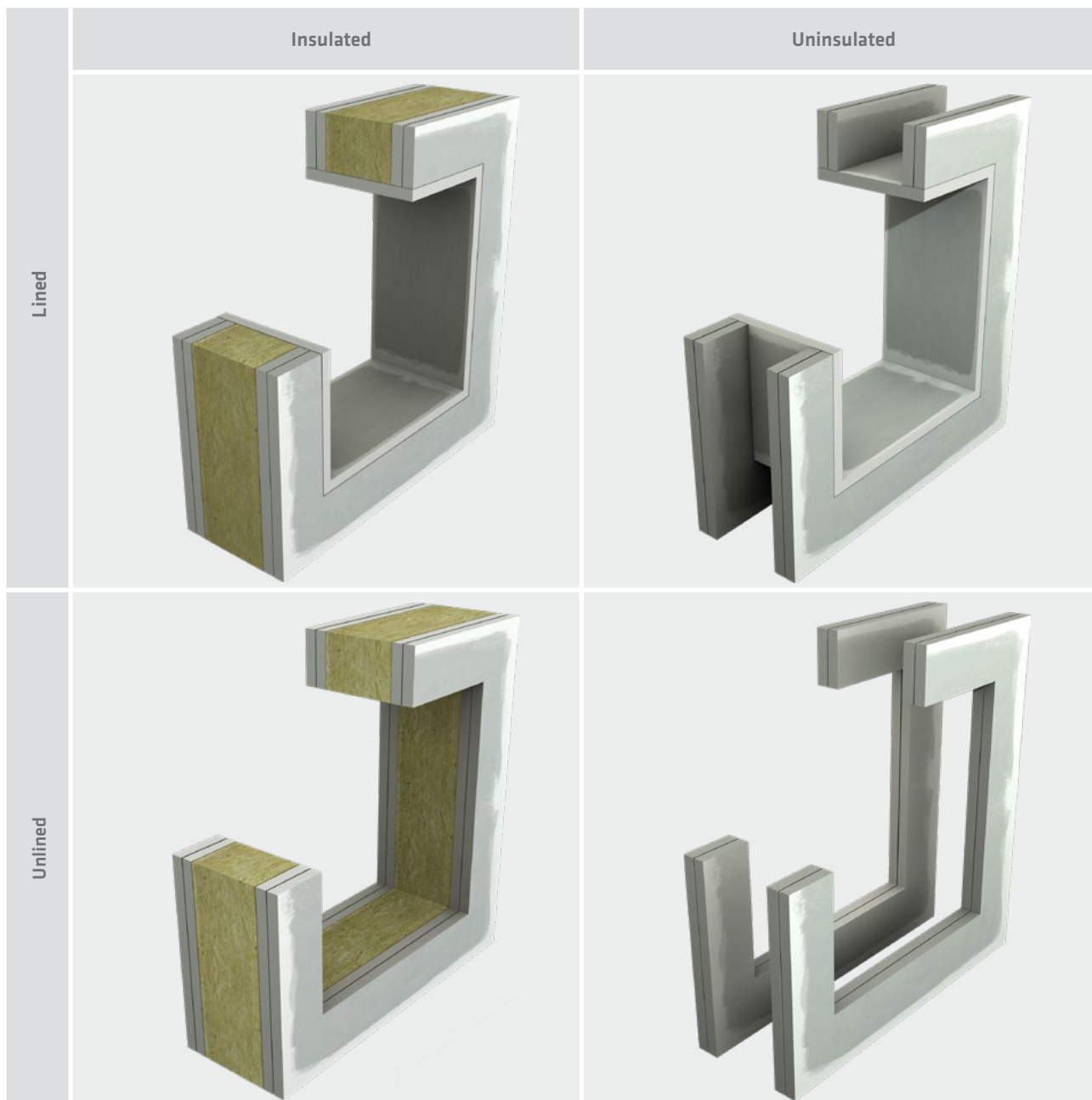

INSULATED AND UNINSULATED PIPES

Pipework used in buildings is either insulated or uninsulated, but despite this very clear definition, the topic of pipe insulation in passive fire protection applications can lead to confusion: To try and clarify this: There are 4 different configurations and even uninsulated pipes can be classified as insulated!

This diagram (acc. EN 1366-4, simplified) shows the 4 classifications.

Cases CS and CI cover insulated pipes where the pipes are either supplied with continuous insulation or continuous insulation is applied on site (case CS). However, this continuous insulation may be interrupted where the pipe penetrates walls or floors (case CI).

A section of uninsulated pipe can be insulated locally for a limited distance before and after the penetration. Again this type of insulation can be sustained (case LS) or interrupted (case LI).

The scope of any such local insulation is to improve the fire resistance of the penetration seal, whilst the scope of continuous insulation is generally to insulate the complete pipe run for thermal or other reasons such as acoustics etc.

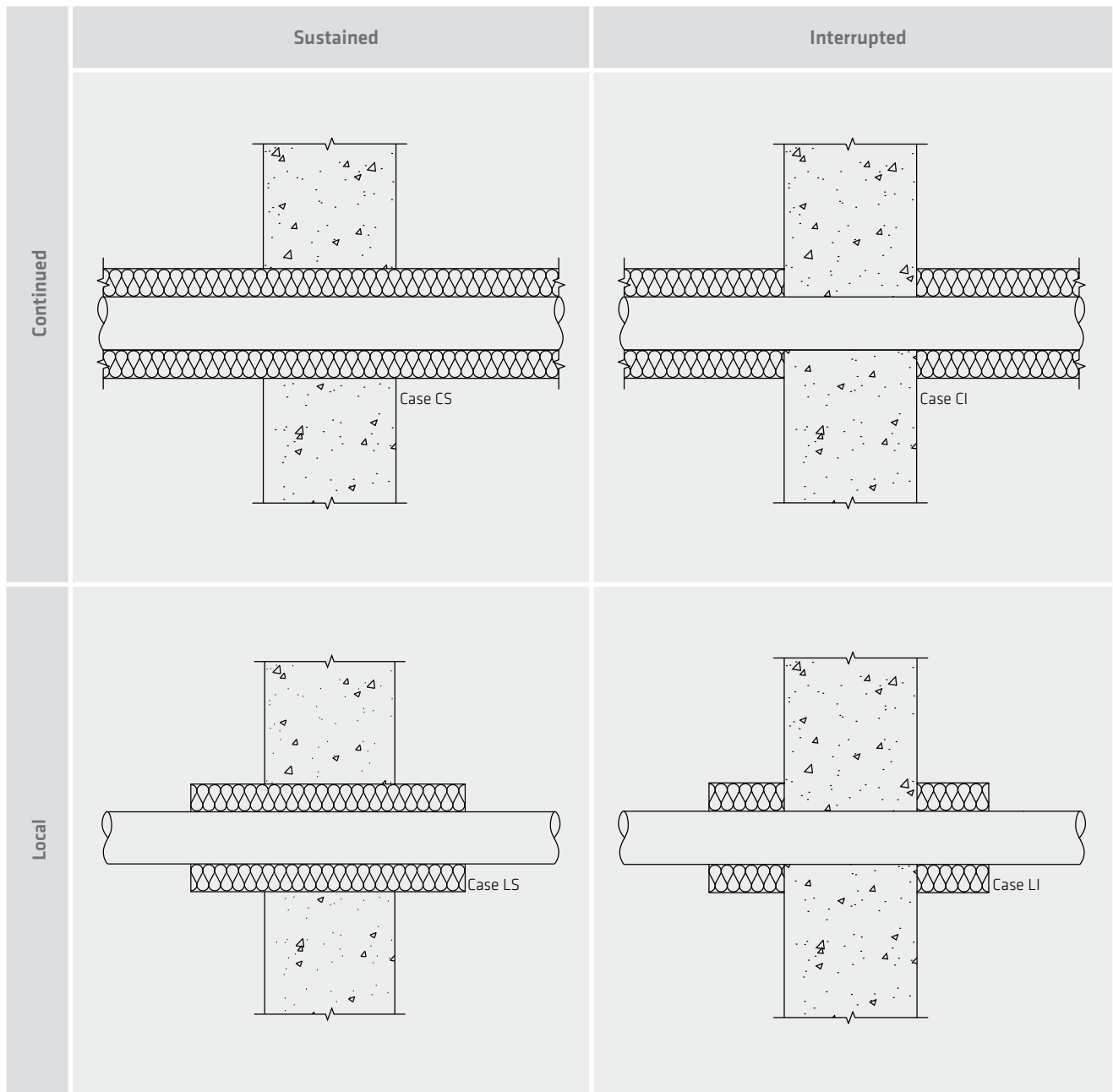

PIPE DIAMETER, PIPE WALL THICKNESS

When testing penetration seals around pipes, the pipe diameter as well as the pipe wall thickness are relevant because they both have a direct influence on the test result. Tested combinations of pipe diameters and pipe wall thicknesses may also cover other dimensions and types of pipes. To explain further, 3 pipes of different diameters and wall thicknesses are tested and then interpolation rules allow this testing to also cover pipes with wall thicknesses and diameters in between these dimensions.

In this document test data is shown in tables or in diagrams like the one below. In this example – which is partially overlapping – 3 different pipe materials are shown (PE, PP, PVC). Example Pipe A (90 mm diameter, 12 mm wall thickness) is covered by the testing if made from PP or PE but not PVC; whilst with Example Pipe B (160 mm diameter, 5 mm wall thickness), this is covered if made from PP only. Finally as shown with Example Pipe C (125 mm diameter, 2 mm wall thickness), this dimension is not covered for any type of material.

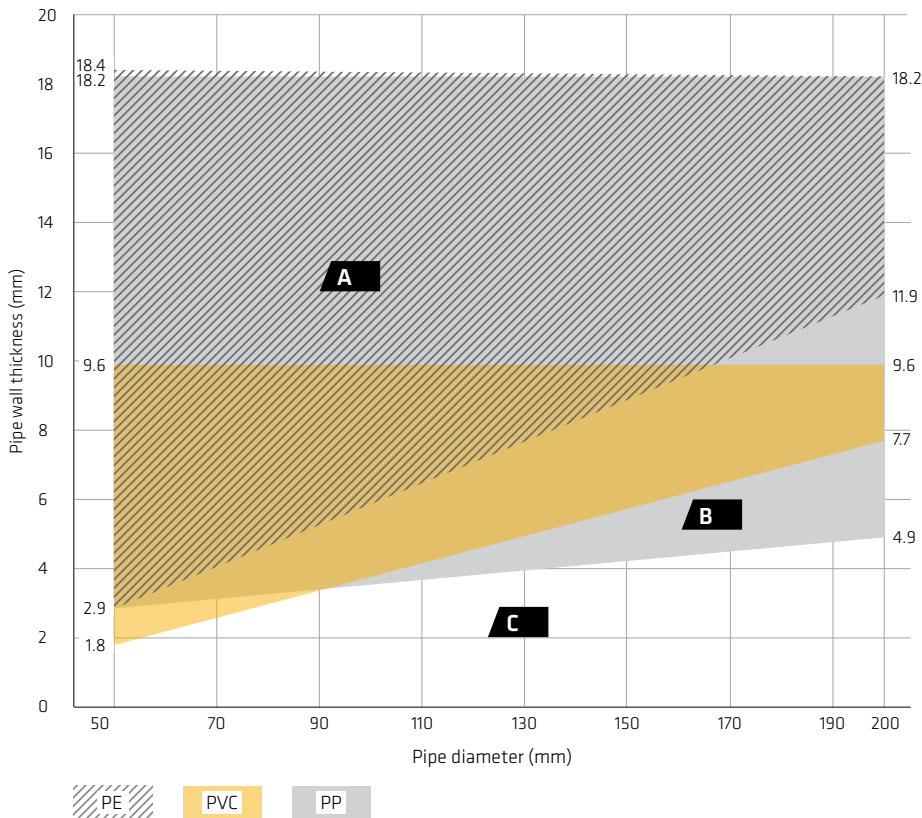

PIPE END-CONFIGURATIONS

The pipe end-configuration for fire protection describes whether the ends of a pipe are closed or open (C for capped and U for uncapped). EN 1366-3 defines 4 possible pipe end configurations considering that each pipe has two ends, one on its exposed side (in the furnace) and one on its unexposed side (outside the furnace). The pipe end configuration has a significant influence on the heat flux during a fire and hence on the fire resistance rating of the penetration seal under test. The tables below shows that the testing of a defined configuration also covers other less severe configurations in similar applications.

PLASTIC PIPES

Tested configuration	Covered configurations
U/U	U/U, C/U, U/C, C/C
C/U	C/U, U/C, C/C
U/C	U/C, C/C
C/C	C/C

METAL PIPES

Tested configuration	Covered configurations
U/U	U/U, U/C, C/U, C/K
U/C	U/C, C/U, C/C
C/U	C/U, C/C
C/C	C/C

The first letter represents the end of the pipe on the exposed end while the second letter stands for the unexposed end of the pipe. For example a pipe classified as U/C indicates that the pipe was tested uncapped in the furnace and capped outside the furnace.

An uncapped pipe end does not necessarily mean that this pipe ends in a compartment or room with a capping, but in most cases it will continue to another compartment, or leave the building without opening. Soil and vent pipes for example are generally uncapped at the drainage end and closed (uncapped configuration, not having any opening) until they leave the building. Closed circuits like gas supply pipes, compressed air or similar are capped at both ends.

PENETRATION SERVICES SUPPORT

Penetration services like pipes, cables or cable trays are mechanically supported. Pipe hangers – anchored in the ceiling – are the most popular support device for pipes penetrating walls. The distance between wall and support device may influence the fire resistance performance of a system, hence this so called “support distance” is an important variable for each penetration layout.

The shorter the distance between pipe support and wall the better the performance of the system. Consequently supports may be placed closer to the wall/floor than tested but not further away. For all our penetration layouts you will find the maximum allowable distance between wall and support device, this distance applies to both sides of the wall. For penetration seals in floor this distance only applies to the upper side of the floor.

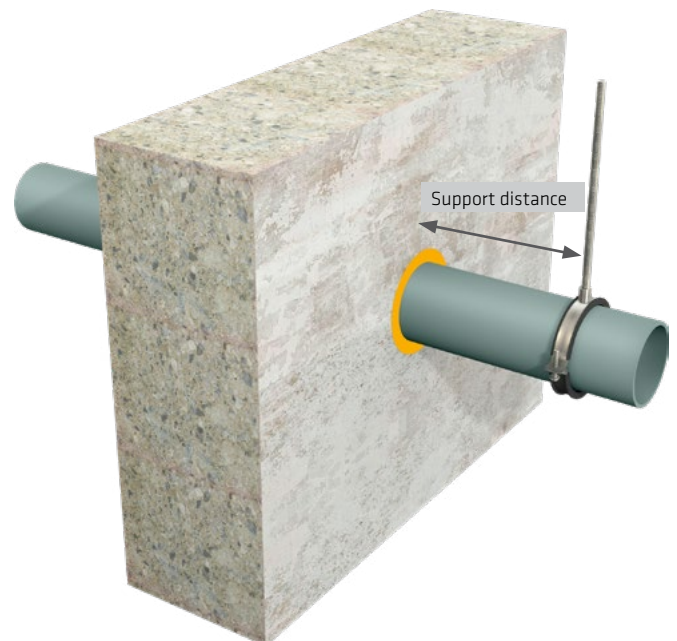

PIPE AND INSULATION MATERIAL

The variety of plastic materials used for combustible pipes and pipe insulations is wide. Many of these plastic types have different physical characteristics (e.g. softening point or melting point) which means that pipes made from different materials will perform differently when exposed to fire. In order to minimise test effort without compromising on safety EN 1366-3 defines plastic materials which are covered if other, similar materials are tested.

Class	Tested material	Covered material
PVC	PVC-U	PVC-U, PVC-C
PP	PP	PP
PE	PE-HD	PE, ABS, SAN + PVC

Abbrev.	Explanation
PVC	Polyvinyl chloride
PVC-U	Unplasticised PVC known as "hard PVC"
PVC-C	Chlorinated PVC
PP	Polypropylene
PE	Polyethylene
PE-HD	High density PE
SAN	Styrene acrylonitrile copolymer
SAN + PVC	Styrene copolymer blend material

COMBINING MULTIPLE SERVICES IN ONE APERTURE

This book describes different applications of penetration seals around pipes, cables and cable trays. Each example shows only one utility or service pipe, whilst under certain conditions several services may be combined to pass through one large aperture:

For example with SikaSeal®-626 Fire Board and Sikacrete®-630 Fire, the maximum aperture size is stated for each different type of application. Within these limitations multiple services can be combined, provided that they are all based on the same

configuration (e.g. two boards in a flexible wall). The maximum aperture size as well as the resistance to fire rating of the combined seal will be no-better than the lowest size and rating of all of the individual seals included. The total cross section of all of the services combined must be $\leq 60\%$ of the total aperture size (area). The minimum distances for sealing around and between each of the individual service pipes, as well as the distance to the edges of the aperture must be respected in all situations.

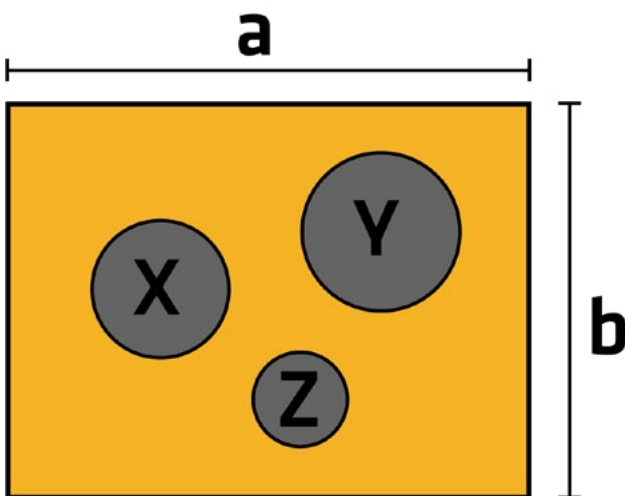

$$X+Y+Z \leq 0.6 (ab)$$





SELECTION GUIDE AND SOLUTIONS TO LINEAR SEALS

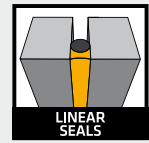

Sika provides a full range of fire resistant products for linear seals. Some applications can be covered by several alternative products, others – more specific ones – by just one. The following guide is intended to help you find the most efficient solution to any given application:

■ Firstly, use the diagram below starting with the column on the left (walls, floors/head of walls or cavity barriers), working left to right to select the relevant code (A – G) letter(s) in the right hand column.

■ Secondly, in the table below find the codes from the diagram and use the corresponding line(s) to find the products that are suitable for your application. Then for full details please refer to the corresponding product page of this document.

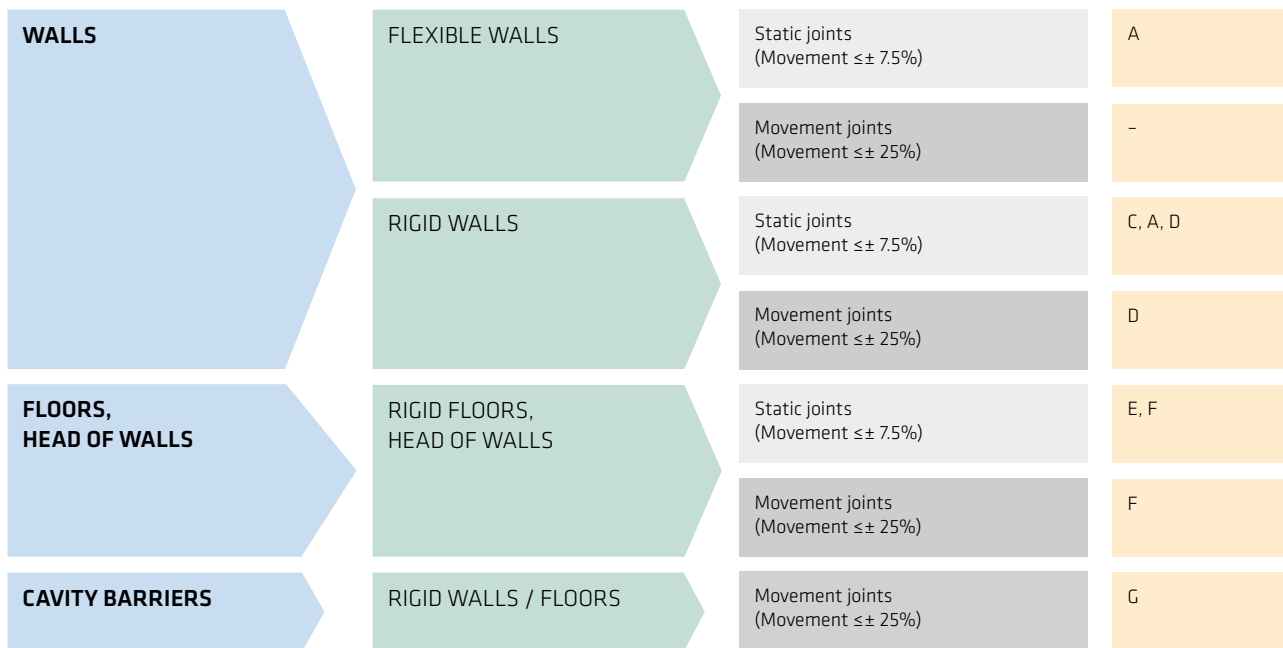

Key	Use	Product	Page
A	Static joints in flexible walls*	Sikacryl®-621 Fire	28
C	Static joints in rigid walls*	Sikacryl®-620 Fire	27
		Sikacryl®-621 Fire	28
		Sika® Backer Rod Fire	29 – 31
		Sikasil®-670 Fire	24 – 25
		Sika Boom®-400 Fire	32
		Sikaflex®-400 Fire	26
D	Movement joints in rigid walls	Sikasil®-670 Fire	24 – 25
E	Static joints in floors or head of wall applications*	Sikacryl®-620 Fire	27
		Sikacryl®-621 Fire	28
		Sika® Backer Rod Fire	29 – 31
		Sikasil®-670 Fire	24 – 25
F	Movement joints in floors or head of wall applications	Sikasil®-670 Fire	24 – 25
G	Cavity barriers	Sikacryl®-624 Fire	31

* Static joints can accommodate max. $\pm 7.5\%$ movement (acc. FAD 350141-00-1106)

PRODUCT OVERVIEW LINEAR SEALS

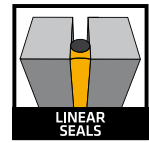

Product	Description	Typical uses	Main advantages
	Sikasil®-670 Fire Neutral cure, fire resistant silicone sealant	<ul style="list-style-type: none"> ■ Static and elastic floor- and wall joints ■ Indoor and outdoor use 	<ul style="list-style-type: none"> ■ Compensates ± 25% movement also in case of fire (tested acc. EN 1366-4) ■ For wall joints – horizontal and vertical ■ For floor joints ■ Can be used on various substrates
	Sikacryl®-621 Fire Phthalate-free, fire resistant acrylic sealant	<ul style="list-style-type: none"> ■ Static floor and wall joints ■ Indoor use 	<ul style="list-style-type: none"> ■ Easy to use, easy to clean ■ System component used in conjunction with many products for penetration seals
	Sikacryl®-620 Fire Fire resistant acrylic sealant	<ul style="list-style-type: none"> ■ Static floor and wall joints ■ Indoor use 	<ul style="list-style-type: none"> ■ Easy to use, easy to clean
	Sika® Backer Rod Fire Mineral wool based, non-combustible, fire resistant backer rod used in combination with SikaHyflex®-250 Facade, Sikaflex® AT Connection or Sikaflex® PRO-3	<ul style="list-style-type: none"> ■ Static floor and wall joints ■ Indoor and outdoor use 	<ul style="list-style-type: none"> ■ For wall joints – horizontal and vertical ■ For floor joints ■ Outstanding fire resistance even in single seal configuration
	Sikaflex®-400 Fire Fire resistant PU sealant	<ul style="list-style-type: none"> ■ Static floor and wall joints ■ Indoor and outdoor use 	<ul style="list-style-type: none"> ■ For wall and floor joints ■ Suitable for hot / humid climatic conditions
	Sika Boom®-400 Fire Fire resistant expansion foam	<ul style="list-style-type: none"> ■ Static floor and wall joints ■ Indoor use 	<ul style="list-style-type: none"> ■ Tested for joints up to 45 mm width ■ High volume expansion ■ Easy to apply
	Sikacryl®-624 Fire Fire resistant acrylic sealant/ coating	<ul style="list-style-type: none"> ■ Static and elastic floor- and wall joints ■ Indoor use 	<ul style="list-style-type: none"> ■ Suitable for joint up to 200 mm width ■ Compensates ± 25% movement also in case of fire (tested acc. EN 1366-4) ■ Very easy to apply by pouring, spraying or brushing

Sikasil®-670 Fire

Resistance to fire of **vertical** linear seals in **rigid walls** (wall thickness ≥ 150 mm) sealed with Sikasil®-670 Fire. Tested acc. EN 1366-4 and classified acc. EN 13501-2/EAD 350141-00-1106.

Substrates	Movement	Configuration	Joint width (mm)	Joint depth (mm)	Resistance Class
Concrete* / Concrete	$\pm 25\%$	1	12 – 50	0.5 x width	EI 240
	$\pm 25\%$	2	10 – 30	15	EI 45, E 180
	$\pm 25\%$	2	12 – 50	0.5 x width	EI 30, E 240
	$\pm 25\%$	3	10 – 30	15	EI 45, E 60
	$\pm 25\%$	3	30 – 50	0.5 x width	EI 45, E 60
	$\pm 7.5\%$	1	12 – 50	0.5 x width	EI 240
	$\pm 7.5\%$	2	12 – 50	0.5 x width	EI 60, E 240
	$\pm 7.5\%$	3	10 – 30	15	EI 60, E 240
Concrete* / Steel	$\pm 7.5\%$	1	12 – 30	0.5 x width	EI 60, E 240
	$\pm 7.5\%$	1	30 – 50	0.5 x width	EI 90, E 240
	$\pm 7.5\%$	2	12 – 50	0.5 x width	EI 15, E 240
Concrete* / Softwood	$\pm 7.5\%$	1	12 – 50	0.5 x width	EI 120
	$\pm 7.5\%$	2	12 – 50	0.5 x width	EI 90
Concrete* / Hardwood	$\pm 7.5\%$	1	12 – 30	0.5 x width	EI 180
	$\pm 7.5\%$	1	30 – 50	0.5 x width	EI 240

* Brickwork, concrete or aerated concrete with a density ≥ 760 kg/m³

CONFIGURATIONS



1. Double seal

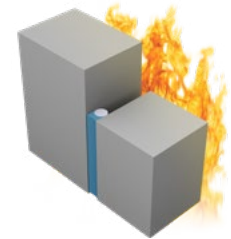

2. Single seal, unexposed side



3. Single seal, exposed side

Resistance to fire of **horizontal** linear seals in **rigid walls** (wall thickness ≥ 150 mm) sealed with Sikasil®-670 Fire. Tested acc. EN 1366-4 and classified acc. EN 13501-2/EAD 350141-00-1106.

Substrates	Movement	Configuration	Joint width (mm)	Joint depth (mm)	Resistance Class
Concrete* / Concrete	$\pm 25\%$	1	12 – 50	0.5 x width	EI 180, E 240
	$\pm 25\%$	2	12 – 50	0.5 x width	EI 60, E 120
	$\pm 25\%$	3	10 – 30	15	EI 45, E 60
	$\pm 25\%$	3	30 – 50	0.5 x width	EI 45, E 60
	$\pm 7.5\%$	1	12 – 50	0.5 x width	EI 240
	$\pm 7.5\%$	2	12 – 50	0.5 x width	EI 60, E 240
	$\pm 7.5\%$	3	10 – 30	15	EI 60, E 180
	$\pm 7.5\%$	3	30 – 50	0.5 x width	EI 60, E 90

* Brickwork, concrete or aerated concrete with a density ≥ 760 kg/m³

CONFIGURATIONS



1. Double seal



2. Single seal, unexposed side



3. Single seal, exposed side

Sikasil®-670 Fire

Resistance to fire of linear seals in **rigid floors** (floor thickness ≥ 150 mm) sealed with Sikasil®-670 Fire. Tested acc. EN 1366-4 and classified acc. EN 13501-2/EAD 350141-00-1106.

Substrates	Movement	Configuration	Joint width (mm)	Joint depth (mm)	Resistance Class
Concrete* / Concrete	$\pm 25\%$	1	12 – 50	0.8 x width	EI 180, E 240
	$\pm 25\%$	2	12 – 50	0.8 x width	EI 60, E 240
	$\pm 25\%$	3	12 – 50	0.8 x width	EI 60, E 90
	$\pm 7.5\%$	1	12 – 50	0.8 x width	EI 240
	$\pm 7.5\%$	2	12 – 30	0.8 x width	EI 120, E 240
	$\pm 7.5\%$	2	30 – 50	0.8 x width	EI 60, E 240
	$\pm 7.5\%$	3	12 – 50	0.8 x width	EI 60
Concrete* / Steel	$\pm 7.5\%$	1	12 – 50	0.8 x width	EI 60, E 240
	$\pm 7.5\%$	2	12 – 50	0.8 x width	EI 60, E 90
	$\pm 7.5\%$	3	12 – 50	0.8 x width	EI 60, E 90

* Brickwork, concrete or aerated concrete with a density ≥ 760 kg/m³

CONFIGURATIONS



1. Double seal

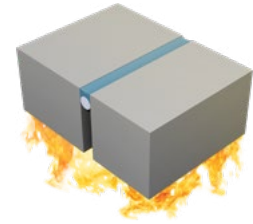

2. Single seal, unexposed side

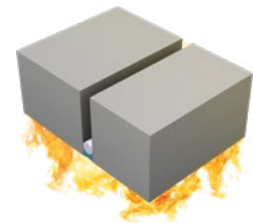

3. Single seal, exposed side

Sikaflex®-400 Fire

Resistance to fire of **vertical** linear seals in **rigid walls** (wall thickness ≥ 150 mm) sealed with Sikaflex®-400 Fire. Tested acc. AS 1530.4 / EN 1366-4 and classified acc. EN 13501-2.

Substrates	Configuration	Joint width (mm)	Joint depth (mm)	Resistance Class***
Concrete** / Concrete	1	25	10	EI 180, E 240
	2	10 – 40	0.5 x width	EI 120, E 240
Concrete* / Concrete	2	10 – 40	0.5 x width	EI 120

* Brickwork, concrete or aerated concrete with a density ≥ 760 kg/m³

** Precast concrete

*** EI 180, E 240 acc. EN 13501-2 is the equivalent of “-/240/180” acc. AS 1530.4

CONFIGURATIONS



1. Double seal

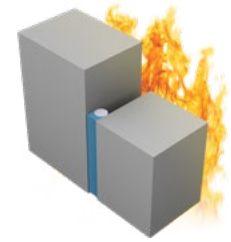

2. Single seal, unexposed side

Resistance to fire of linear seals in **rigid floors** (floor thickness ≥ 200 mm) sealed with Sikaflex®-400 Fire. Tested acc. AS 1530.4 / EN 1366-4 and classified acc. EN 13501-2.

Substrates	Configuration	Joint width (mm)	Joint depth (mm)	Resistance Class***
Concrete* / Concrete	1	12 – 40	0.8 x width	EI 240
	2	12 – 40	0.8 x width	EI 120

* Brickwork, concrete or aerated concrete with a density ≥ 760 kg/m³

CONFIGURATIONS



1. Double seal



2. Single seal, unexposed side

Sikacryl®-620 Fire

Resistance to fire of **vertical** linear seals in **rigid walls** (wall thickness ≥ 150 mm) sealed with Sikacryl®-620 Fire. Movement $\leq \pm 7.5\%$. Tested acc. EN 1366-4 and classified acc. EN 13501-2/ETAG 026.

Substrates	Configuration	Joint width (mm)	Joint depth (mm)	Resistance Class
Concrete* / Concrete	1	12 – 50	0.5 x width	EI 240
Concrete* / Softwood	1	12	0.5 x width	EI 60, E 120
	1	13 – 49	0.5 x width	EI 120
	1	50	0.5 x width	EI 180
Concrete* / Hardwood	1	12 – 49	0.5 x width	EI 180
	1	50	0.5 x width	EI 180
Concrete* / Steel	1	12 – 49	0.5 x width	EI 90, E 240
	1	50	0.5 x width	EI 120, E240

* Brickwork, concrete or aerated concrete with a density ≥ 760 kg/m³

CONFIGURATIONS

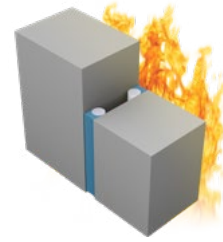

1. Double seal

Resistance to fire of linear seals in **rigid floors** (floor thickness ≥ 150 mm) sealed with Sikacryl®-620 Fire. Tested acc. EN 1366-4 and classified acc. EN 13501-2/ETAG 026.

Substrates	Configuration	Joint width (mm)	Joint depth (mm)	Resistance Class
Concrete* / Concrete	1	12 – 50	0.5 x width	EI 120, E240
Concrete* / Steel	1	12 – 50	0.5 x width	EI 30, E240

* Brickwork, concrete or aerated concrete with a density ≥ 760 kg/m³

CONFIGURATIONS

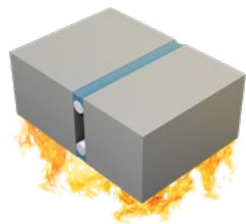

1. Double seal

Sikacryl®-621 Fire

Resistance to fire of **vertical** linear joints in **rigid and flexible walls** sealed with Sikacryl®-621 Fire. Movement $\leq \pm 7.5\%$. Tested acc. EN 1366-4 and classified acc. EN 13501-2/EAD 350141-00-1106.

Substrates	Wall thickness (mm)	Configuration	Joint width (mm)	Joint depth (mm)	Resistance Class
Concrete* / Concrete	≥ 100	3	8 – 20	10	EI 45, E 120
	≥ 100	3	8 – 50	25	EI 60, E 120
	≥ 150	1	8 – 50	20	EI 120, E 240
	$\geq 150^{***}$	2	8 – 50	5	EI 120, E 240
	≥ 150	1	8 – 50	25	EI 240
Concrete* / Steel	≥ 100	3	8 – 20	10	EI 20, E 120
	≥ 100	3	8 – 50	25	EI 30, E 45
	$\geq 150^{****}$	1	8 – 50	30	EI 60, E 240
Concrete* / Softwood	≥ 100	3	8 – 20	10	EI 20, E 30
	≥ 100	3	8 – 50	25	EI 45
	$\geq 150^{****}$	1	8 – 50	30	EI 60
Gypsum walls** / Concrete*	≥ 120	4	8 – 20	12.5	EI 120
	≥ 120	1	8 – 20	12.5	EI 120

* Brickwork, concrete or aerated concrete with a density $\geq 670 \text{ kg/m}^3$
 ** 2 Layers of gypsum board (2 x 15 mm on each side)
 *** Backed with $\geq 60 \text{ kg/}^3$ mineral wool, $\geq 75 \text{ mm}$ deep
 **** Backed with $\geq 45 \text{ kg/}^3$ mineral wool, $\geq 40 \text{ mm}$ deep

CONFIGURATIONS

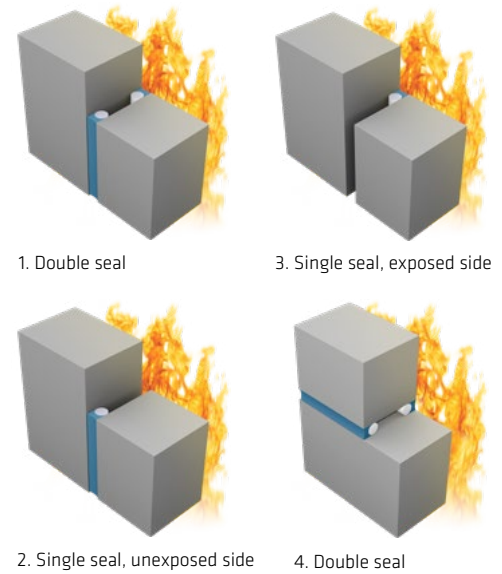

Resistance to fire of linear joints in **floors** as well as **head of walls** (wall thickness $\geq 150 \text{ mm}$) sealed with Sikacryl®-621 Fire. Movement $\leq \pm 7.5\%$. Tested acc. EN 1366-4 and classified acc. EN 13501-2/EAD 350141-00-1106.

Substrates	Configuration	Joint width (mm)	Joint depth (mm)	Resistance Class
Concrete* / Concrete	3/6	8 – 20	10	EI 45, E 240
	3/6	8 – 50	25	EI 90, E 240
	1/4	8 – 50	20	EI 120, E 240
	2/5	8 – 50	5***	EI 120, E 240
Concrete* / Steel	3/6	8 – 20	10	EI 20, E 120
	3/6	8 – 50	25	EI 90, E 240
Concrete* / Softwood	3/6	8 – 20	10	EI 30
	3/6	8 – 50	25	EI 45

* Brickwork, concrete or aerated concrete with a density $\geq 760 \text{ kg/m}^3$
 *** Backed with $\geq 60 \text{ kg/}^3$ mineral wool, $\geq 75 \text{ mm}$ deep

CONFIGURATIONS

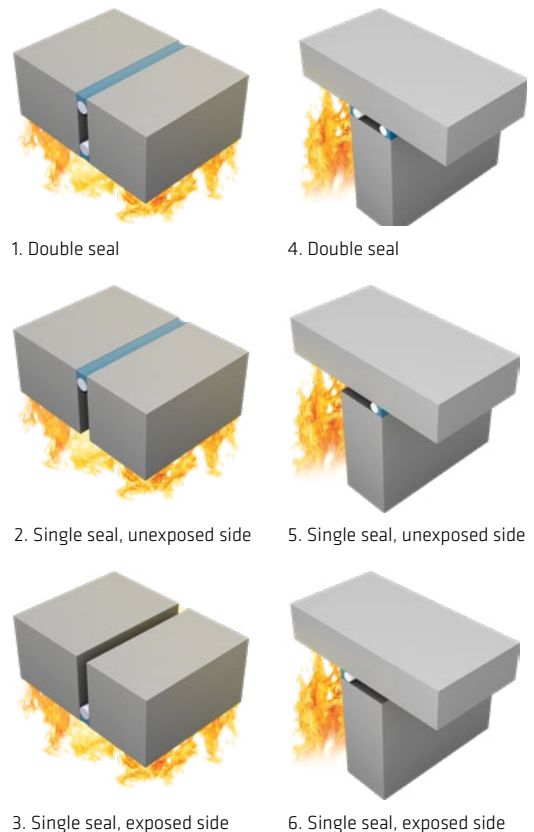

Sika® Backer Rod Fire

Sika® Backer Rod Fire is available in seven different nominal diameters (see y-axis of the diagram) Refer to the number at the right edge of the yellow bar in the diagram, as each diameter of Sika® Backer Rod Fire may only be used for nominal joint widths below this value. The number at the left edge of

the bar refers to the lower nominal joint width limit, since Sika® Backer Rod Fire can only be compressed to a certain degree. For example, for a nominal 50 mm diameter Sika® Backer Rod Fire, the lower limit threshold joint width is 32 mm, and the maximum joint width is 42.5 mm.

Use of Sika® Backer Rod Fire depending on the joint width

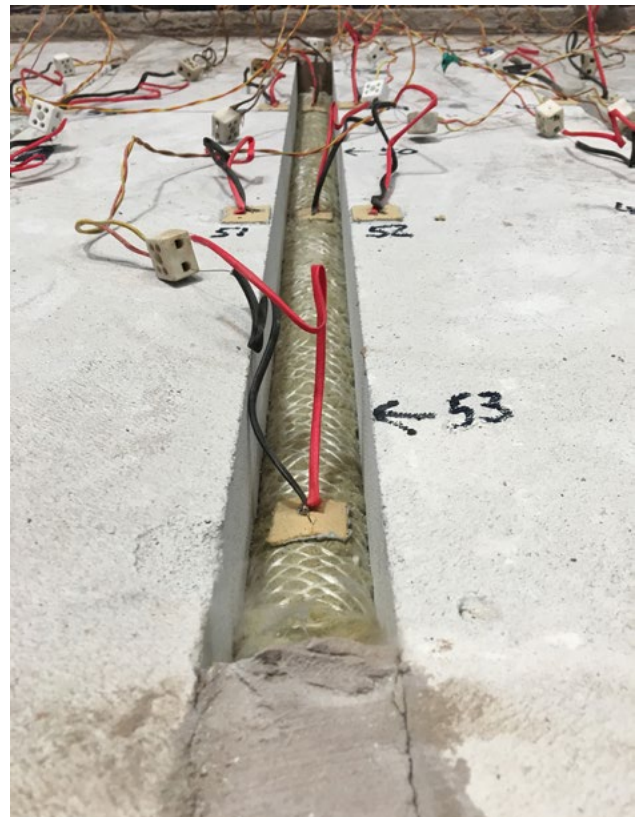
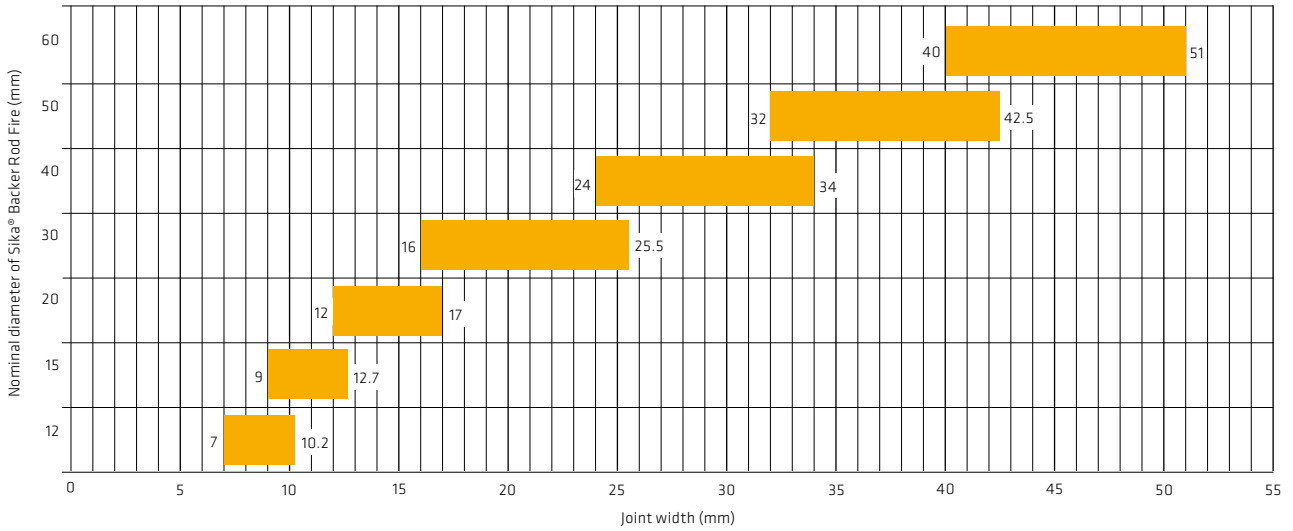

Sika® Backer Rod Fire

Resistance to fire of **vertical** linear seals in **rigid walls*** (wall thickness ≥ 150 mm) sealed with Sika® Backer Rod Fire combined with SikaHyflex®-250 Facade, Sikaflex® AT Connection or Sikaflex® PRO-3. Movement $\leq \pm 7.5\%$. Tested acc. EN 1366-4 and classified acc. EN 13501-2/EAD 350141-00-1106.

Sealant	Configuration	Joint width (mm)	Joint depth (mm)	Resistance Class
SikaHyflex®-250 Facade	1	7 – 51	0.5 x width	EI 240
	2	7 – 51	0.5 x width	EI 180, E 240
	3	7 – 51	0.5 x width	EI 120, E 240
Sikaflex® AT Connection	1	7 – 51	0.5 x width	EI 240
	2	7 – 51	0.5 x width	EI 180, E 240
	3	7 – 51	0.5 x width	EI 180, E 240
Sikaflex® PRO-3	2	7 – 51	0.5 x width	EI 180, E 240
	3	7 – 51	0.5 x width	EI 45, E 120

* Brickwork, concrete or aerated concrete with a density ≥ 760 kg/m³

CONFIGURATIONS

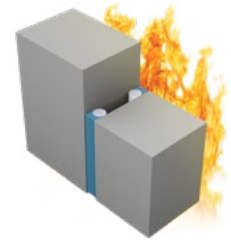

1. Double seal



2. Single seal, unexposed side



3. Single seal, exposed side

Resistance to fire of **horizontal** linear seals in **rigid walls*** (wall thickness ≥ 150 mm) sealed with Sika® Backer Rod Fire combined with SikaHyflex®-250 Facade, Sikaflex® AT Connection. Movement $\leq \pm 7.5\%$. Tested acc. EN 1366-4 and classified acc. EN 13501-2/EAD 350141-00-116.

Sealant	Configuration	Joint width (mm)	Joint depth (mm)	Resistance Class
SikaHyflex®-250 Facade	2	7 – 51	0.5 x width	EI 240
	3	7 – 51	0.5 x width	EI 90, E 180
Sikaflex® AT Connection	2	7 – 51	0.5 x width	EI 240
	3	7 – 51	0.5 x width	EI 120, E 240

* Brickwork, concrete or aerated concrete with a density ≥ 760 kg/m³

CONFIGURATIONS



2. Single seal, unexposed side



3. Single seal, exposed side

Sika® Backer Rod Fire

Resistance to fire of linear joints in **rigid floors*** (floor thickness ≥ 200 mm) sealed with Sika® Backer Rod Fire combined with SikaHyflex®-250 Facade**, Sikaflex® AT Connection** or Sikaflex® PRO-3. Movement $\leq \pm 7.5\%$. Tested acc. EN 1366-4 and classified acc. EN 13501-2/EAD 350141-00-1106.

Substrates	Configuration	Joint width (mm)	Joint depth (mm)	Resistance Class
Sikaflex® PRO-3	1	7 – 51	0.8 x width	EI 240
	2	7 – 51	0.8 x width	EI 240
	3	7 – 51	0.8 x width	EI 60, E 240
SikaHyflex®-250 Facade	1**	7 – 51	0.8 x width	EI 240
	2**	7 – 51	0.8 x width	EI 240
	3	7 – 51	0.8 x width	EI 120, E 180
Sikaflex® AT Connection	1**	7 – 51	0.8 x width	EI 240
	2**	7 – 51	0.8 x width	EI 240
	3	7 – 51	0.8 x width	EI 120, E 180

* Brickwork, concrete or aerated concrete with a density ≥ 760 kg/m³

** Not approved for pedestrian walkways acc. EN 15651-4 in the European Union

CONFIGURATIONS



1. Double seal



2. Single seal, unexposed side



3. Single seal, exposed side

Sika Boom®-400 Fire

Resistance to fire of **vertical** linear joints in **rigid walls*** (wall thickness ≥ 200 mm) sealed with Sika Boom®-400 Fire. Movement $\pm 7.5\%$. Tested acc. EN 1366-4 and classified acc. EN 13501-2.

Configuration	Application type	Joint width (mm)	Joint depth (mm)	Resistance Class
2	gun	≤ 10	200	EI 240
2	gun	≤ 30	180	EI 120
2	gun	≤ 45	180	EI 60
2	gun	≤ 20	120	EI 240
2	gun	≤ 35	120	EI 90
2	nozzle	≤ 10	200	EI 240
2	nozzle	≤ 30	160	EI 120
2	nozzle	≤ 45	160	EI 90
2	nozzle	≤ 20	100	EI 180
2	nozzle	≤ 35	100	EI 60

* Brickwork, concrete or aerated concrete with a density ≥ 760 kg/m³

CONFIGURATIONS

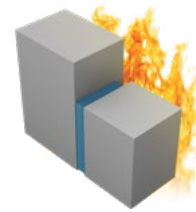

2. Single seal, unexposed side

Resistance to fire of linear joints in **floors*** (floor thickness ≥ 200 mm) sealed with Sika Boom®-400 Fire. Movement $\pm 7.5\%$. Tested acc. EN 1366-4 and classified acc. EN 13501-2.

Configuration	Application type	Joint width (mm)	Joint depth (mm)	Resistance Class
2	gun	≤ 10	200	EI 240
2	gun	≤ 30	180	EI 120
2	gun	≤ 45	180	EI 60
2	gun	≤ 20	120	EI 180
2	gun	≤ 35	120	EI 60
2	nozzle	≤ 10	200	EI 240
2	nozzle	≤ 30	160	EI 90
2	nozzle	≤ 45	160	EI 60
2	nozzle	≤ 20	100	EI 180
2	nozzle	≤ 35	100	EI 60

* Brickwork, concrete or aerated concrete with a density ≥ 760 kg/m³

CONFIGURATIONS



2. Single seal, unexposed side

Sikacryl®-624 Fire

Resistance to fire of cavity barriers in **floors** (floor thickness ≥ 150 mm) sealed with Sikacryl®-624 Fire. Tested acc. EN 1366-4 and classified acc. EN 13501-2/EAD 350141-00-1106.

CONFIGURATIONS

Substrates	Movement	Configuration	Joint width (mm)	Joint depth (mm)	Resistance Class
Concrete* / Concrete	$\pm 25\%$	1	10 – 200**	1***	EI 180, E 240
	$\pm 25\%$	2	10 – 200**	1***	EI 180, E 240

* Brickwork, concrete or aerated concrete with a density ≥ 760 kg/m³

** Backed with ≥ 80 kg/m³ mineral wool, ≥ 100 mm deep

*** ≥ 1 mm dry film thickness, equals to ≥ 2 mm wet film thickness

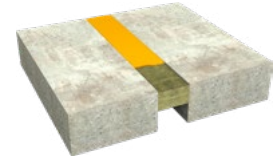

1. Cavity barrier in floor

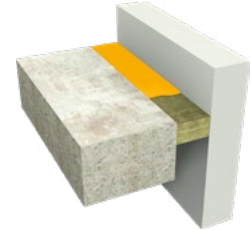

2. Cavity barrier between wall and floor

SELECTION GUIDE AND SOLUTIONS TO PENETRATION SEALS



Sika offers a full range of fire resistant products for penetration seals. Some applications can be covered by several products, others – more specific ones – just by one. The following guide will help you to select the best solution to a given application.

will find an overview to all applications covering a certain type of penetration, followed by detailed descriptions of each layout. Before choosing one specific layout check all other layouts of the same penetration type (e.g. all layouts for insulated metal pipes).

How to use this selection guide

Use the below diagram to find the relevant type of layout for your application and browse to corresponding page. There you

SEPARATING ELEMENT	APERTURE SIZE*	PENETRATION SERVICE TYPE	PAGE
WALL	LARGE APERTURE	Metal pipes insulated	36
		Metal pipes uninsulated	44
		Plastic and MLC pipes	48
		Cables, cable trays and conduits	54
	SMALL APERTURE	Metal pipes insulated	60
		Metal pipes uninsulated	64
		Plastic and MLC pipes	68
		Cables, cable trays and conduits	74
FLOOR	LARGE APERTURE	Metal pipes insulated	**
		Metal pipes uninsulated	76
		Plastic and MLC pipes	80
		Cables, cable trays and conduits	86
	SMALL APERTURE	Metal pipes insulated	90
		Metal pipes uninsulated	**
		Plastic and MLC pipes	92
		Cables, cable trays and conduits	**

* A Large apertures is an opening clearly larger than the penetration service and hence a large surface must be sealed, generally with an insulation board (SikaSeal®-626 Fire Board) or a compound (Sikacrete®-630 Fire).

A small aperture is ± of the same size as the penetration service and only limited surface must be sealed. Mostly small apertures are core drilled holes for pipes or cables.

** Not covered by this handbook

Large aperture



Small aperture (core drilled hole)



PRODUCT OVERVIEW PENETRATION SEALS



Product	Description	Typical uses	Main advantages
	SikaSeal®-623 Fire Intumescent, fire resistant sealant	<ul style="list-style-type: none"> ■ Combustible pipes, mainly small diameters 	<ul style="list-style-type: none"> ■ Highly intumescent – volume expansion 20 times original size ■ Easy to apply
	Sikacryl®-625 Fire Fire resistant acrylic coating	<ul style="list-style-type: none"> ■ Edge protection and touch-up on SikaSeal®-626 Fire Board 	<ul style="list-style-type: none"> ■ Easy to apply and clean
	SikaSeal®-626 Fire Board Mineral wool based, fire resistant coated board	<ul style="list-style-type: none"> ■ All kind of penetrations in walls and floors; also in combination with other products 	<ul style="list-style-type: none"> ■ Extremely versatile ■ For face-fit and internal fit installations ■ Can be combined with many other products
	SikaSeal®-627 Fire Collar Intumescent, fire resistant pipe collar	<ul style="list-style-type: none"> ■ Combustible pipes in walls and floors; all diameters. ■ Face-fit installation 	<ul style="list-style-type: none"> ■ Highly intumescent – volume expansion 20 times original size ■ Flexible design enables installation in confined spaces ■ Easy to apply – 1 part, 3 fixings for all sizes
	SikaSeal®-628 Fire Wrap Intumescent, fire resistant pipe wrap	<ul style="list-style-type: none"> ■ Combustible pipes in walls and floors; all diameters. ■ Internal-fit installation 	<ul style="list-style-type: none"> ■ Highly intumescent – volume expansion 20 times original size ■ Ready to use, pre-cut strips for most pipe diameters ■ Invisible installation in walls and floors
	SikaSeal®-629 Fire Wrap Intumescent, fire resistant pipe wrap on a roll	<ul style="list-style-type: none"> ■ Combustible pipes in walls and floors, all diameters. ■ Internal-fit installation 	<ul style="list-style-type: none"> ■ Highly intumescent – volume expansion 20 times original size ■ Cut and use direct from roll ■ Invisible installation in walls and floors
	Sikacrete®-630 Fire Load bearing, fire resistant compound	<ul style="list-style-type: none"> ■ All kind of load bearing penetrations in floors 	<ul style="list-style-type: none"> ■ Excellent load bearing properties ■ Self-supporting in floor penetrations up to 1.8 x 1.8 m ■ Fast setting, no loss of volume

INSULATED METAL PIPES IN WALLS, LARGE APERTURES

Short description	Products	Code	Page
Insulated steel and copper pipes in flexible and rigid walls Glass wool pipe insulation Insulated walls, lined apertures Internal fit board installation	SikaSeal®-626 Fire Board Sikacryl®-621 Fire SikaSeal®-623 Fire	626.5	37
Insulated steel and copper pipes in flexible and rigid walls Glass wool pipe insulation Insulated walls, lined and unlined apertures Internal fit board installation	SikaSeal®-626 Fire Board Sikacryl®-621 Fire	626.6	38
Insulated steel and copper pipes in flexible and rigid walls K-flex pipe insulation Insulated walls, lined and unlined apertures Internal fit board installation	SikaSeal®-626 Fire Board Sikacryl®-621 Fire SikaSeal®-629 Fire Wrap	626.7	39
Insulated steel and copper pipes in flexible and rigid walls Kingspan Kooltherm pipe insulation Insulated walls, lined and unlined apertures Internal fit board installation.	SikaSeal®-626 Fire Board Sikacryl®-621 Fire SikaSeal®-629 Fire Wrap	626.8	40
Insulated steel and copper pipes in flexible and rigid walls K-flex pipe insulation Insulated and uninsulated walls, lined and unlined apertures Face fit (pattress fit) board installation.	SikaSeal®-626 Fire Board Sikacryl®-621 Fire Sikacryl®-625 Fire (Sikacryl®-621 Fire alternatively) SikaSeal®-629 Fire Wrap	626.10	41
Insulated steel and copper pipes in flexible and rigid walls Kingspan Kooltherm pipe insulation Insulated and uninsulated walls, lined and unlined apertures Face fit (pattress fit) board installation.	SikaSeal®-626 Fire Board Sikacryl®-621 Fire Sikacryl®-625 Fire (Sikacryl®-621 Fire alternatively) SikaSeal®-629 Fire Wrap	626.11	42

INSULATED METAL PIPES IN FLEXIBLE AND RIGID WALLS



PRODUCTS, MATERIALS

1. SikaSeal®-626 Fire Board
2. Sikacryl®-621 Fire
3. SikaSeal®-623 Fire

CLASSIFICATION

EI 60 U/C

DETAILS

- Wall: Thickness ≥ 100 mm, ≥ 2 layers of gypsum board each side (≥ 25 mm in total each side) on a steel or timber stud
- Pipes: Diameter ≤ 159 mm, wall thickness 2.3 – 14.2 mm steel and copper or metals with higher melting point and/or lower thermal conductivity
- Pipe insulation: Glass wool, stone wool or ceramic wool, density ≥ 80 kg/m³, thickness 30 mm, CS (continuous sustained)
- SikaSeal®-626 Fire Board internal fit, installed flush on both sides of the wall
- 15 mm annular space around pipes sealed with SikaSeal®-623 Fire, ≥ 15 mm deep, double seal
- Sikacryl®-621 Fire between board and gypsum board
- Aperture size $\leq 730 \times 1,200$ mm
- Distance between pipes (sealant) ≥ 100 mm
- Distance between aperture edge and pipes (sealant) ≥ 100 mm
- Distance between wall and pipe support ≤ 250 mm
- Covers flexible walls (insulated, lined) as well as rigid walls

INSTALLATION INSTRUCTIONS

Refer to the relevant Sika method statement(s)

INSULATED METAL PIPES IN FLEXIBLE AND RIGID WALLS



PRODUCTS, MATERIALS

1. SikaSeal®-626 Fire Board
2. Sikacryl®-621 Fire

CLASSIFICATION

EI 45, E 120 C/U

DETAILS

- Wall: Thickness ≥ 100 mm, ≥ 2 layers of gypsum board each side (≥ 25 mm in total each side) on a steel or timber stud
- Pipes: Diameter ≤ 159 mm, wall thickness 1.2 – 14.2 mm steel and copper or metals with higher melting point and/or lower thermal conductivity
- Pipe insulation: Glass wool, stone wool or ceramic wool, density ≥ 30 kg/ m³, thickness 25 mm, CS (continuous sustained)
- SikaSeal®-626 Fire Board internal fit, installed flush on both sides of the wall
- Sikacryl®-621 Fire between abutting materials
- Aperture size $\leq 730 \times 1,200$ mm
- Distance between pipes (sealant) ≥ 100 mm
- Distance between aperture edge and pipes (sealant) ≥ 100 mm
- Distance between wall and pipe support ≤ 400 mm
- Covers flexible walls (insulated, lined and unlined) as well as rigid walls

INSTALLATION INSTRUCTIONS

Refer to the relevant Sika method statement(s)

INSULATED METAL PIPES IN FLEXIBLE AND RIGID WALLS

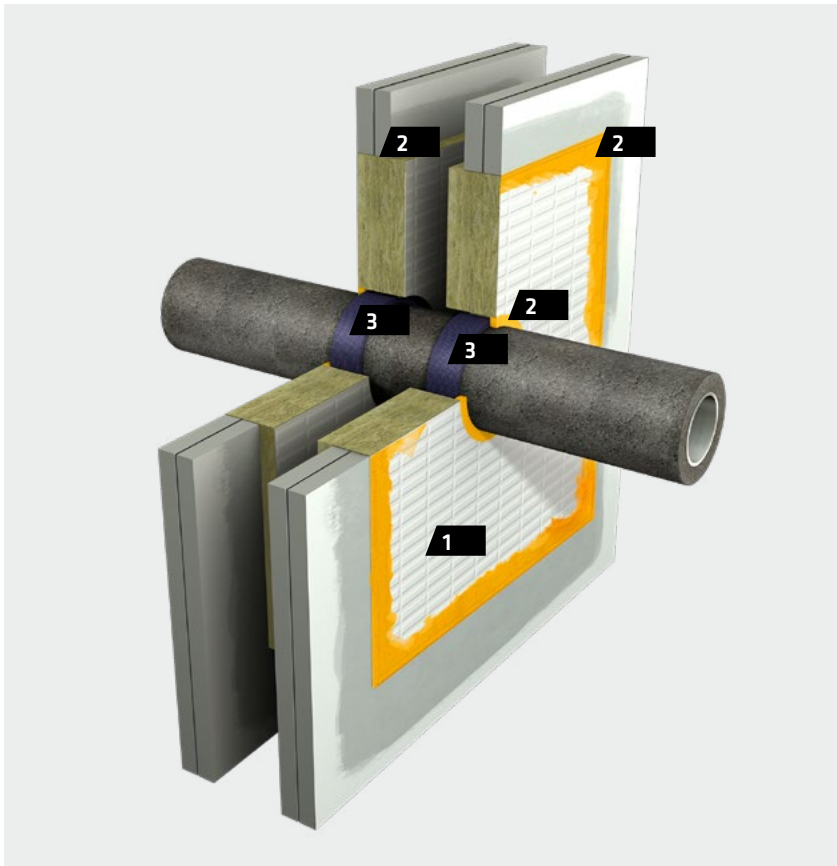

PRODUCTS, MATERIALS

1. SikaSeal®-626 Fire Board
2. Sikacryl®-621 Fire
3. SikaSeal®-629 Fire Wrap

CLASSIFICATION

EI 60, E 120 C/U (for K-FLEX pipes)

EI 60, E 120 C/U (for glass wool insulated pipes)

DETAILS

- Wall: Thickness ≥ 100 mm, ≥ 2 layers of gypsum board each side (≥ 25 mm in total each side) on a steel or timber stud
- Pipes: Diameter ≤ 159 mm, wall thickness 1.2 – 14.2 mm steel and copper or metals with higher melting point and/or lower thermal conductivity
- Pipe insulation: K-FLEX ST foam insulation, thickness 13 – 25 mm; alternatively glass wool, stone wool or ceramic wool, density ≥ 30 kg/m³, thickness 50 mm, CS (continuous sustained)
- SikaSeal®-626 Fire Board internal fit, installed flush on both sides of the wall
- 5 mm annular space around pipes, 2 layers of SikaSeal®-629 Fire Wrap, Sikacryl®-621 Fire 5 mm deep on both sides
- Sikacryl®-621 Fire between board and gypsum board
- Aperture size $\leq 730 \times 1,200$ mm
- Distance between pipes (sealant) ≥ 100 mm
- Distance between aperture edge and pipes (sealant) ≥ 100 mm
- Distance between wall and pipe support ≤ 400 mm
- Covers flexible walls (insulated, lined and unlined) as well as rigid walls

INSTALLATION INSTRUCTIONS

Refer to the relevant Sika method statement(s)

INSULATED METAL PIPES IN FLEXIBLE AND RIGID WALLS

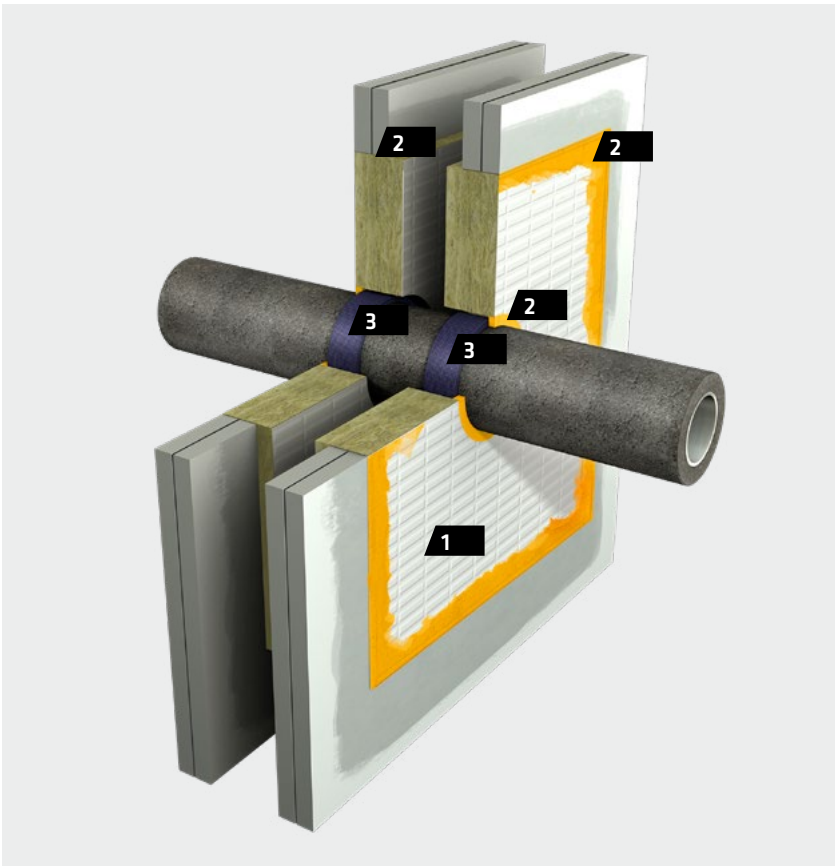

PRODUCTS, MATERIALS

1. SikaSeal®-626 Fire Board
2. Sikacryl®-621 Fire
3. SikaSeal®-629 Fire Wrap

CLASSIFICATION

EI 60, E 120 C/U

DETAILS

- Wall: Thickness ≥ 100 mm, ≥ 2 layers of gypsum board each side (≥ 25 mm in total each side) on a steel or timber stud
- Pipes: Diameter ≤ 108 mm, wall thickness 1.2 – 14.2 mm steel and copper or metals with higher melting point and/or lower thermal conductivity
- Pipe insulation: Kingspan Kooltherm FM, CS (continuous sustained)
- SikaSeal®-626 Fire Board internal fit, installed flush on both sides of the wall
- 5 mm annular space around pipes, 2 layers of SikaSeal®-629 Fire Wrap, Sikacryl®-621 Fire 5 mm deep on both sides
- Sikacryl®-621 Fire between board and gypsum board
- Aperture size $\leq 730 \times 1,200$ mm
- Distance between pipes (sealant) ≥ 100 mm
- Distance between aperture edge and pipes (sealant) ≥ 100 mm
- Distance between wall and pipe support ≤ 400 mm
- Covers flexible walls (insulated, lined and unlined) as well as rigid walls

INSTALLATION INSTRUCTIONS

Refer to the relevant Sika method statement(s)

INSULATED METAL PIPES IN FLEXIBLE AND RIGID WALLS

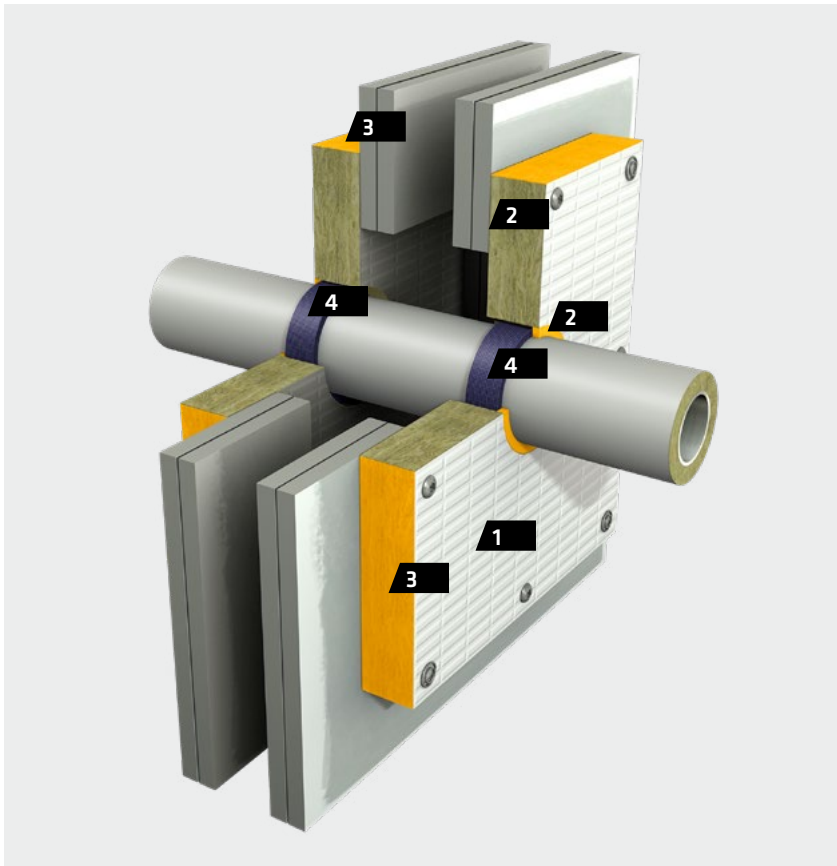

PRODUCTS, MATERIALS

1. SikaSeal®-626 Fire Board
2. Sikacryl®-621 Fire
3. Sikacryl®-625 Fire (Sikacryl®-621 Fire alternatively)
4. SikaSeal®-629 Fire Wrap

CLASSIFICATION

EI 90, E 120 C/U

DETAILS

- Wall: Thickness ≥ 100 mm, ≥ 2 layers of gypsum board each side (≥ 25 mm in total each side) on a steel or timber stud
- Pipes: diameter ≤ 159 mm, wall thickness 1.2 – 14.2 mm steel and copper or metals with higher melting point and/or lower thermal conductivity
- Pipe insulation: K-FLEX ST foam insulation, thickness 13 – 25 mm; alternatively glass wool, stone wool or ceramic wool, density ≥ 30 kg/m³, thickness 25 – 50 mm, CS (continuous sustained)
- SikaSeal®-626 Fire Board face fit (pattress fit) installed on both sides of the wall
- Edge surfaces of boards coated with Sikacryl®-625 Fire or Sikacryl®-621 Fire
- Overlap between board and wall ≥ 100 mm
- 5 mm annular space around pipes, 2 layers of SikaSeal®-629 Fire Wrap, Sikacryl®-621 Fire 5 mm deep on both sides
- Sikacryl®-621 Fire between board and wall
- Aperture size $\leq 730 \times 1,200$ mm
- Distance between pipes (wrap) ≥ 100 mm
- Distance between aperture edge and pipes (wrap) ≥ 100 mm
- Distance between wall and pipe support ≤ 400 mm
- Covers flexible walls (insulated and uninsulated, lined and unlined) as well as rigid walls

INSTALLATION INSTRUCTIONS

Refer to the relevant Sika method statement(s)

INSULATED METAL PIPES IN FLEXIBLE AND RIGID WALLS

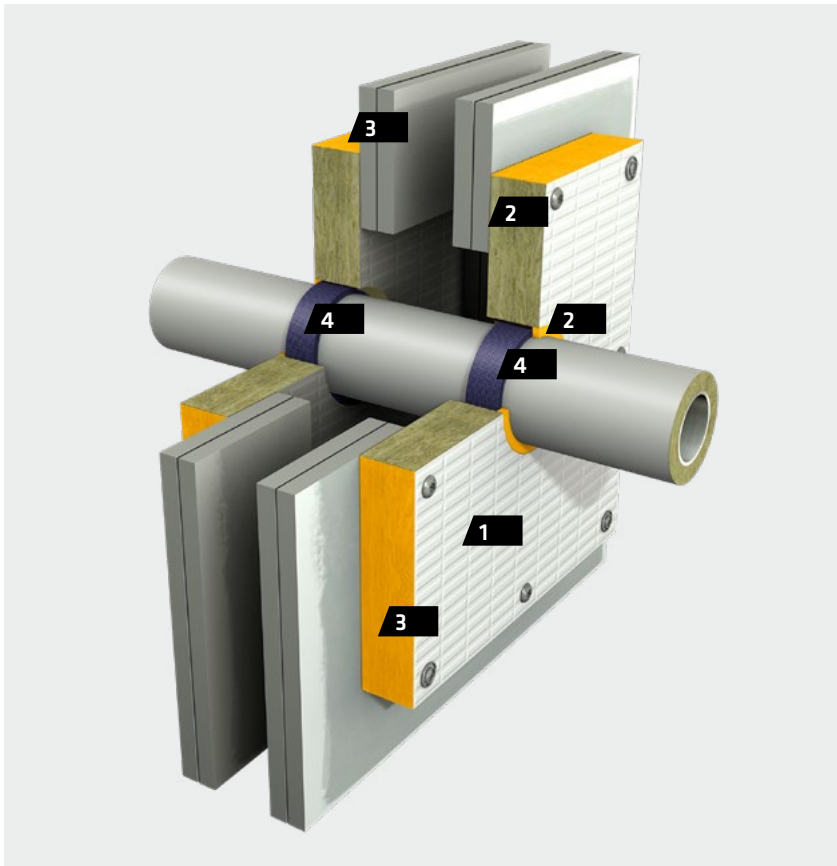

PRODUCTS, MATERIALS

1. SikaSeal®-626 Fire Board
2. Sikacryl®-621 Fire
3. Sikacryl®-625 Fire
(Sikacryl®-621 Fire alternatively)
4. SikaSeal®-629 Fire Wrap

CLASSIFICATION

EI 90, E 120 C/U

DETAILS

- Wall: Thickness ≥ 100 mm, ≥ 2 layers of gypsum board each side (≥ 25 mm in total each side) on a steel or timber stud
- Pipes: diameter ≤ 108 mm, wall thickness 1.2 – 14.2 mm steel and copper or metals with higher melting point and/or lower thermal conductivity
- Pipe insulation: Kingspan Kooltherm FM, CS (continuous sustained)
- SikaSeal®-626 Fire Board face fit (pattress fit) installed on both sides of the wall
- Edge surfaces of boards coated with Sikacryl®-625 Fire or Sikacryl®-621 Fire
- Overlap between board and wall ≥ 100 mm
- 5 mm annular space around pipes, 2 layers of SikaSeal®-629 Fire Wrap, Sikacryl®-621 Fire 5 mm deep on both sides
- Sikacryl®-621 Fire between board and wall
- Aperture size $\leq 730 \times 1,200$ mm
- Distance between pipes (wrap) ≥ 100 mm
- Distance between aperture edge and pipes (wrap) ≥ 100 mm
- Distance between wall and pipe support ≤ 400 mm
- Covers flexible walls (insulated and uninsulated, lined and unlined) as well as rigid walls

INSTALLATION INSTRUCTIONS

Refer to the relevant Sika method statement(s)

Layout: 626.11/626.G

UNINSULATED METAL PIPES IN WALLS, LARGE APERTURES

Short description	Products	Code	Page
Uninsulated steel and copper pipes in flexible and rigid walls Insulated walls, lined and unlined apertures Internal fit board installation	SikaSeal®-626 Fire Board Sikacryl®-621 Fire Pipe insulation	626.2	45
Uninsulated steel pipes in flexible and rigid walls Insulated walls, lined and unlined apertures Internal fit board installation.	SikaSeal®-626 Fire Board Sikacryl®-621 Fire Sikacryl®-625 Fire	626.3	46
Uninsulated steel pipes in flexible and rigid walls Insulated walls, lined and unlined apertures Internal fit board installation	SikaSeal®-626 Fire Board Sikacryl®-621 Fire Sikacryl®-625 Fire	626.4	47

UNINSULATED METAL PIPES IN FLEXIBLE AND RIGID WALLS

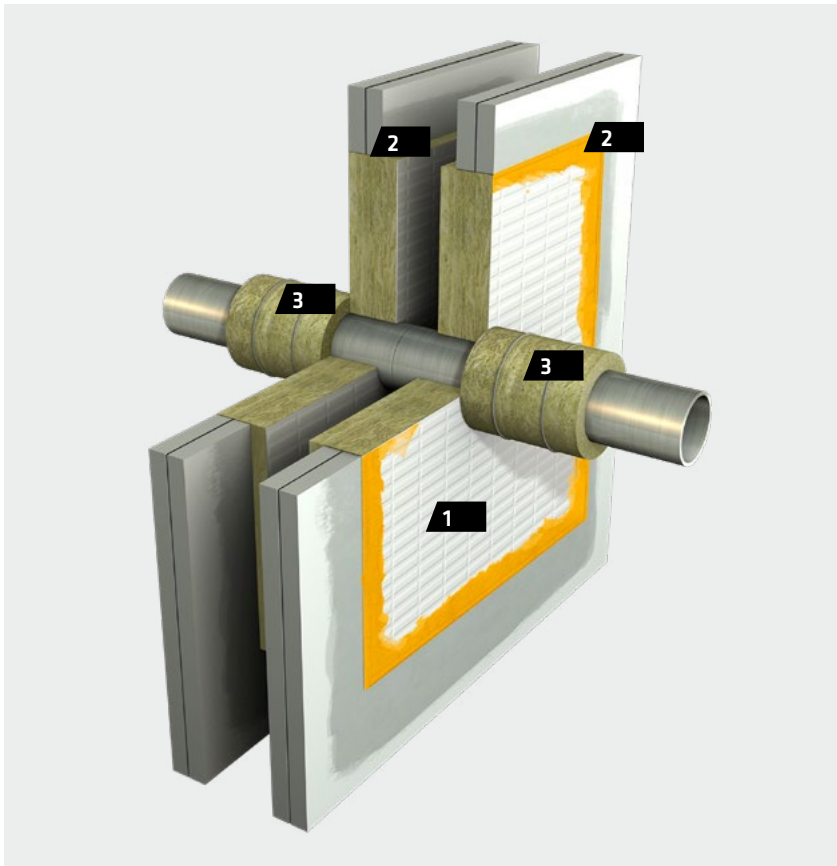

PRODUCTS, MATERIALS

1. SikaSeal®-626 Fire Board
2. Sikacryl®-621 Fire
3. Pipe insulation

CLASSIFICATION

EI 45 C/U

DETAILS

- Wall: Thickness ≥ 100 mm, ≥ 2 layers of gypsum board each side (≥ 25 mm in total each side) on a steel or timber stud
- Pipes: Diameter ≤ 324 mm, wall thickness 14.2 - 16 mm, steel or metals with higher melting point and/or lower thermal conductivity
- Pipe insulation: Stone wool, density ≥ 45 kg/m³, thickness ≥ 40 mm, length ≥ 400 mm, both sides of the wall, LI (local interrupted)
- SikaSeal®-626 Fire Board internal fit, installed flush on both sides of the wall
- Sikacryl®-621 Fire between abutting materials
- Aperture size $\leq 730 \times 1,200$ mm
- Distance between pipes ≥ 0 mm
- Distance between aperture edge and insulation ≥ 50 mm
- Distance between wall and pipe support ≤ 400 mm
- Covers flexible walls (insulated, lined and unlined) as well as rigid walls

INSTALLATION INSTRUCTIONS

Refer to the relevant Sika method statement(s)

UNINSULATED METAL PIPES IN FLEXIBLE AND RIGID WALLS

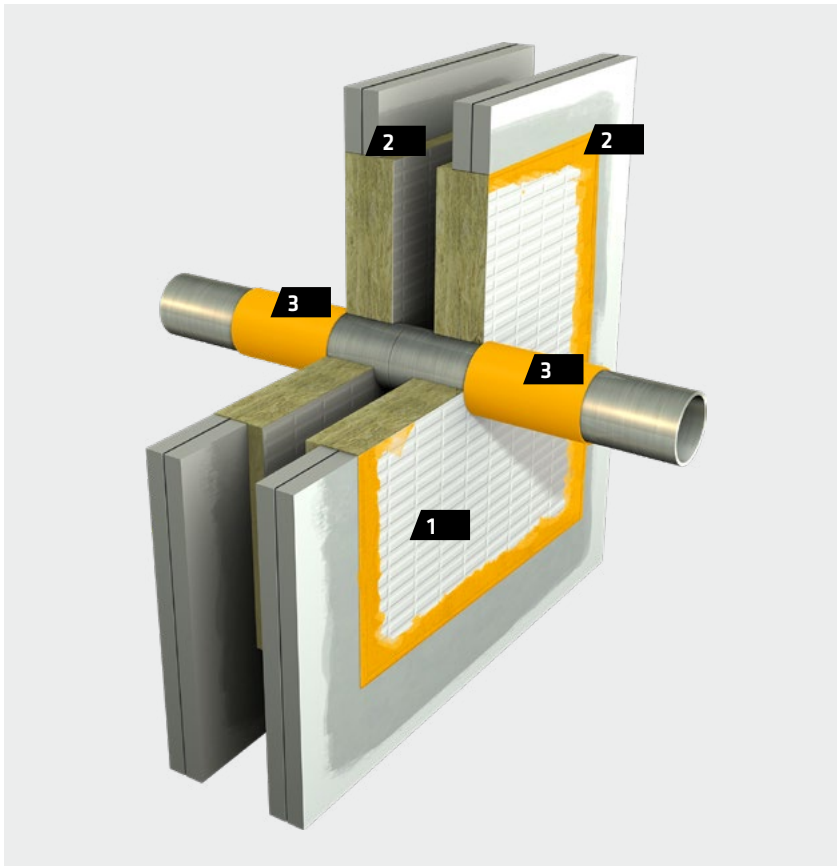

PRODUCTS, MATERIALS

1. SikaSeal®-626 Fire Board
2. Sikacryl®-621 Fire
3. Sikacryl®-625 Fire

CLASSIFICATION

EI 45, E 120 C/U

DETAILS

- Wall: Thickness ≥ 100 mm, ≥ 2 layers of gypsum board each side (≥ 25 mm in total each side) on a steel or timber stud
- Pipes: Diameter ≤ 159 mm wall thickness 1.2 - 14.2 mm, steel and copper or metals with higher melting point and/or lower thermal conductivity
- Pipe insulation: Sikacryl®-625 Fire, thickness ≥ 2 mm, length ≥ 400 mm, both sides of the wall, LI (local interrupted)
- SikaSeal®-626 Fire Board internal fit, installed flush on both sides of the wall
- Sikacryl®-621 Fire between abutting materials
- Aperture size $\leq 730 \times 1,200$ mm
- Distance between pipes ≥ 0 mm
- Distance between aperture edge and insulation ≥ 50 mm
- Distance between wall and pipe support ≤ 400 mm
- Covers flexible walls (insulated, lined and unlined) as well as rigid walls

INSTALLATION INSTRUCTIONS

Refer to the relevant Sika method statement(s)

Layout: 626.3/626.B

UNINSULATED METAL PIPES IN FLEXIBLE AND RIGID WALLS

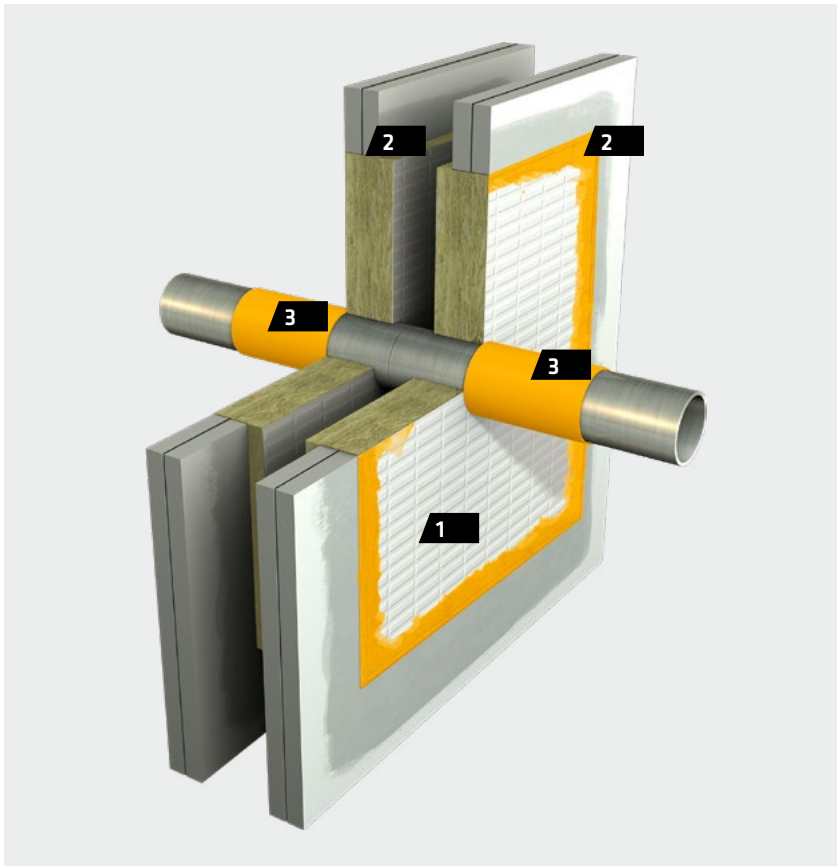

PRODUCTS, MATERIALS

1. SikaSeal®-626 Fire Board
2. Sikacryl®-621 Fire
3. Sikacryl®-625 Fire

CLASSIFICATION

EI 30, E 120 C/U

DETAILS

- Wall: Thickness ≥ 100 mm, ≥ 2 layers of gypsum board each side (≥ 25 mm in total each side) on a steel or timber stud
- Pipes: Diameter ≤ 324 mm, wall thickness 14.2 - 16 mm steel or metals with higher melting point and/or lower thermal conductivity
- Pipe insulation: Sikacryl®-625 Fire, thickness ≥ 2 mm, length ≥ 400 mm, both sides of the wall, LI (local interrupted)
- SikaSeal®-626 Fire Board internal fit, installed flush on both sides of the wall
- Sikacryl®-621 Fire between abutting materials
- Aperture size $\leq 730 \times 1,200$ mm
- Distance between pipes ≥ 0 mm
- Distance between aperture edge and insulation ≥ 50 mm
- Distance between wall and pipe support ≤ 400 mm
- Covers flexible walls (insulated, lined and unlined) as well as rigid walls

INSTALLATION INSTRUCTIONS

Refer to the relevant Sika method statement(s)

PLASTIC AND MLC PIPES IN WALLS, LARGE APERTURES

Short description	Products	Code	Page
Plastic pipes in flexible and rigid walls Insulated walls, lined and unlined apertures Internal fit board installation	SikaSeal®-626 Fire Board Sikacryl®-621 Fire SikaSeal®-627 Fire Collar	627.5	49
Plastic pipes in flexible and rigid walls Insulated and uninsulated walls, lined and unlined apertures Face fit (pattress fit) board installation	SikaSeal®-626 Fire Board Sikacryl®-621 Fire Sikacryl®-625 Fire (Sikacryl®-621 Fire alternatively) SikaSeal®-627 Fire Collar	627.6	50
Plastic pipes in flexible and rigid walls Insulated and uninsulated walls, lined and unlined apertures Face fit (pattress fit) board installation	SikaSeal®-626 Fire Board Sikacryl®-621 Fire Sikacryl®-625 Fire (Sikacryl®-621 Fire alternatively) SikaSeal®-628 Fire Wrap (SikaSeal®-629 Fire Wrap alternatively)	626.13	51
Plastic pipes in rigid walls Internal fit board installation	SikaSeal®-626 Fire Board Sikacryl®-621 Fire SikaSeal®-623 Fire	626.14	52
MLC pipes in rigid walls Internal fit board installation	SikaSeal®-626 Fire Board Sikacryl®-621 Fire SikaSeal®-623 Fire	626.15	53

PLASTIC PIPES IN FLEXIBLE AND RIGID WALLS

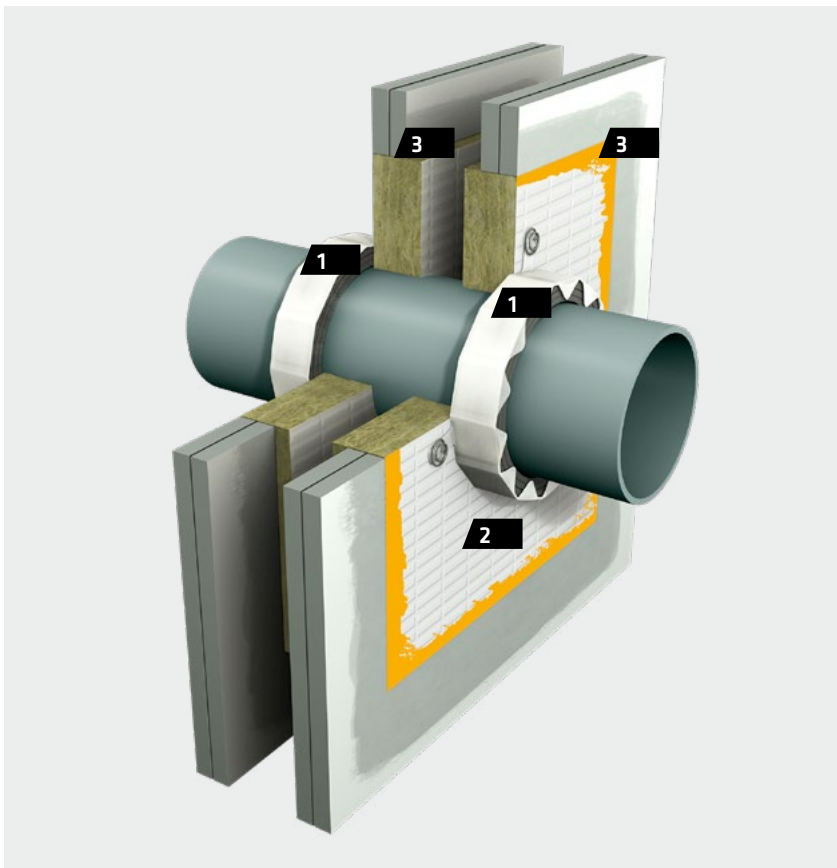

PRODUCTS, MATERIALS

1. SikaSeal®-627 Fire Collar
2. SikaSeal®-626 Fire Board
3. Sikacryl®-621 Fire

CLASSIFICATION

EI 120 U/C for all pipes, see diagram below

DETAILS

- Wall: Thickness ≥ 100 mm, ≥ 2 layers of gypsum board each side (≥ 25 mm in total each side) on a steel or timber stud
- Pipe details see diagram below
- SikaSeal®-626 Fire Board internal fit, installed flush on both sides of the wall
- Sikacryl®-621 Fire between abutting materials
- SikaSeal®-627 Fire collar on both sides
- Aperture size $\leq 730 \times 1,200$ mm
- Distance between collars ≥ 0 mm
- Distance between aperture edge and collar ≥ 50 mm
- Distance between wall and pipe support ≤ 400 mm
- Covers flexible walls (insulated, unlined and lined) as well as rigid walls

INSTALLATION INSTRUCTIONS

Refer to the relevant Sika method statement(s)

Pipe diameter, collar diameter (mm)	PVC*	PP	PE**
	Pipe wall thickness (mm)		
32	1.8	2.9	2.9
40	1.8	2.9	2.9
50	1.8	2.9	2.9
55	2.3 - 3.0	2.9 - 4.4	2.9 - 4.4
63	2.3 - 3.0	2.9 - 4.4	2.9 - 4.4
75	3.1 - 4.8	2.8 - 6.7	2.8 - 6.7
82	3.1 - 4.8	2.8 - 6.7	2.8 - 6.7
90	4.2 - 7.4	2.7 - 10.0	2.7 - 10.0
100	4.2 - 7.4	2.7 - 10.0	2.7 - 10.0
110	4.2 - 7.4	2.7 - 10.0	2.7 - 10.0
125	6	3.1	3.1
140	6.1 - 7.5	3.5 - 8.0	3.9 - 5.8
160	6.2 - 9.5	4.0 - 14.6	4.9 - 9.5

* PVC-U, PVC-C

** PE HD, ABS, SAN + PVC

See chapter "Pipe and insulation material"

Layout: 627.5/627.E

PLASTIC PIPES IN FLEXIBLE AND RIGID WALLS

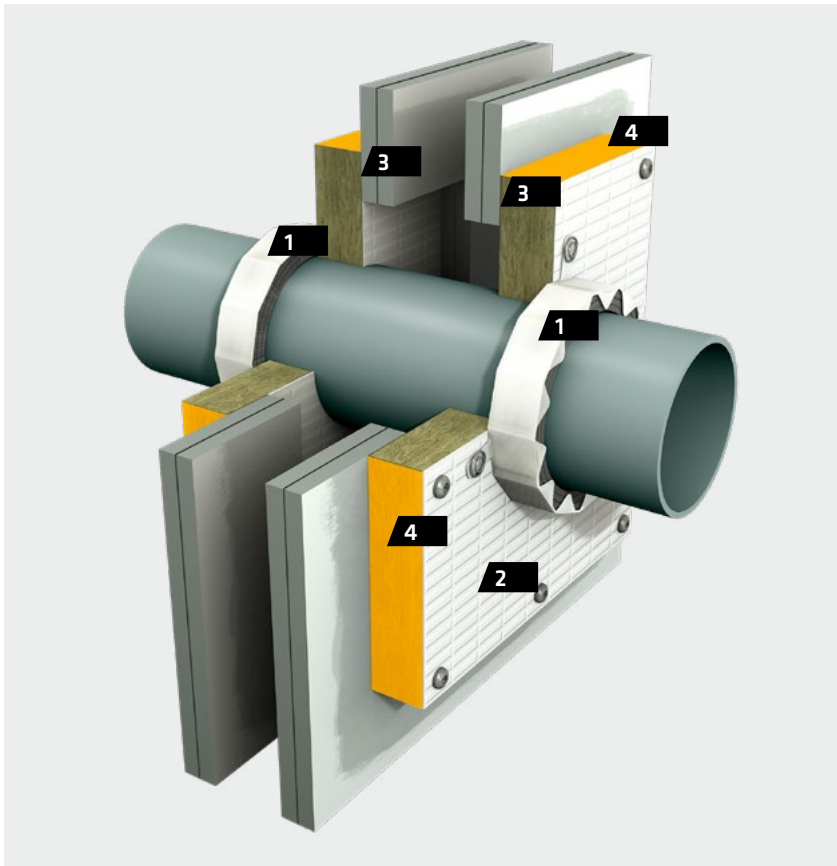

PRODUCTS, MATERIALS

1. SikaSeal®-627 Fire Collar
2. SikaSeal®-626 Fire Board
3. Sikacryl®-621 Fire
4. Sikacryl®-625 Fire
(Sikacryl®-621 Fire alternatively)

CLASSIFICATION

EI 120 U/C for all pipes, see diagram below

DETAILS

- Wall: Thickness ≥ 100 mm, 2 layers of gypsum board each side (≥ 25 mm in total each side) on a steel or timber stud
- Pipe details see diagram below
- SikaSeal®-626 Fire Board face fit (pattress fit) installed on both sides of the wall
- Sikacryl®-621 Fire between abutting materials
- SikaSeal®-627 Fire collar on both sides
- Edge surfaces of boards coated with Sikacryl®-625 Fire or Sikacryl®-621 Fire
- Overlap between board and wall ≥ 100 mm
- Aperture size $\leq 730 \times 1,200$ mm
- Distance between collars ≥ 0 mm
- Distance between board edge and collar ≥ 50 mm
- Distance between wall and pipe support ≤ 400 mm
- Covers flexible walls (insulated and uninsulated, lined and unlined) as well as rigid walls

INSTALLATION INSTRUCTIONS

Refer to the relevant Sika method statement(s)

Pipe diameter, collar diameter (mm)	PVC*	PP	PE**
	Pipe wall thickness (mm)		
32	1.8	2.9	2.9
40	1.8	2.9	2.9
50	1.8	2.9	2.9
55	2.3 - 3.0	2.9 - 4.4	2.9 - 4.4
63	2.3 - 3.0	2.9 - 4.4	2.9 - 4.4
75	3.1 - 4.8	2.8 - 6.7	2.8 - 6.7
82	3.1 - 4.8	2.8 - 6.7	2.8 - 6.7
90	4.2 - 7.4	2.7 - 10.0	2.7 - 10.0
100	4.2 - 7.4	2.7 - 10.0	2.7 - 10.0
110	4.2 - 7.4	2.7 - 10.0	2.7 - 10.0
125	6	3.1	3.1
140	6.1 - 7.5	3.5 - 8.0	3.9 - 5.8
160	6.2 - 9.5	4.0 - 14.6	4.9 - 9.5

* PVC-U, PVC-C

** PE HD, ABS, SAN + PVC

See chapter "Pipe and insulation material"

Layout: 627.6/627.F

PLASTIC PIPES IN FLEXIBLE AND RIGID WALLS

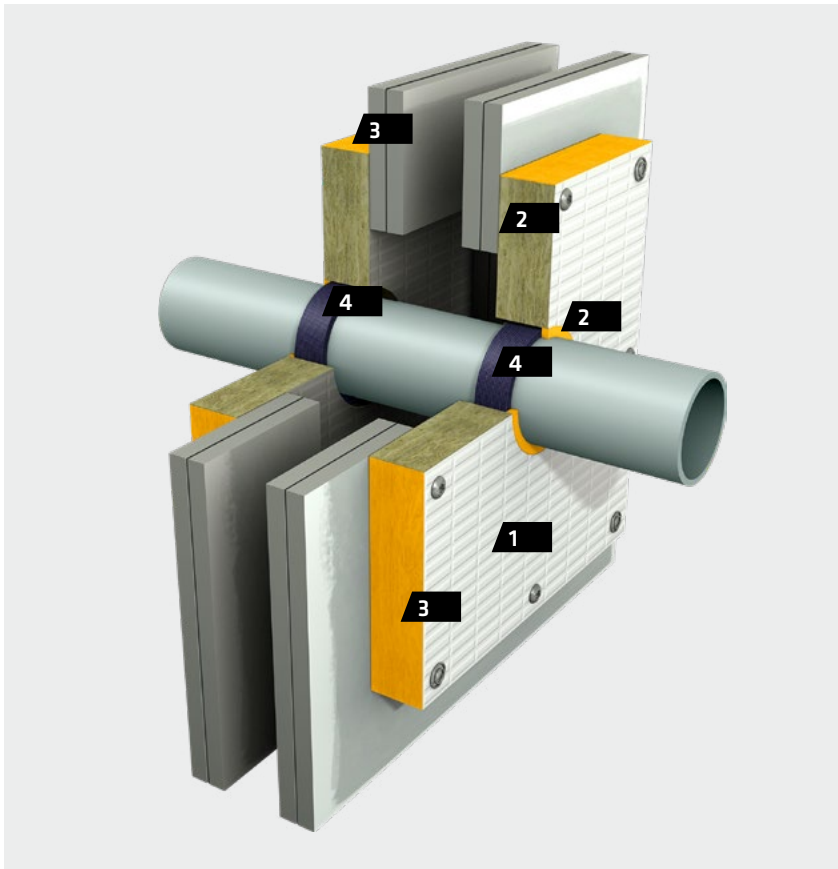

PRODUCTS, MATERIALS

1. SikaSeal®-626 Fire Board
2. Sikacryl®-621 Fire
3. Sikacryl®-625 Fire (Sikacryl®-621 Fire alternatively)
4. SikaSeal®-628 Fire Wrap (SikaSeal®-629 Fire Wrap alternatively)

CLASSIFICATION

EI 60 U/C

DETAILS

- Wall: Thickness ≥ 100 mm, ≥ 2 layers of gypsum board each side (≥ 25 mm in total each side) on a steel or timber stud
- Pipe details see diagram below
- SikaSeal®-626 Fire Board face fit (pattress fit) installed on both sides of the wall
- Edge surfaces of boards coated with Sikacryl®-625 Fire or Sikacryl®-621 Fire
- Overlap between board and wall ≥ 100 mm
- Annular space around pipes see table below
- SikaSeal®-628 Fire Wrap according to pipe diameter on both sides; alternatively SikaSeal®-629 Fire Wrap according to table below on both sides
- Sikacryl®-621 Fire 5 mm deep on both sides
- Sikacryl®-621 Fire between board and wall
- Aperture size $\leq 730 \times 1,200$ mm
- Distance between pipes (wrap) ≥ 0 mm
- Distance between aperture edge and pipes (wrap) ≥ 50 mm
- Distance between wall and pipe support ≤ 400 mm
- Covers flexible walls (insulated and uninsulated, lined and unlined) as well as rigid walls

Pipe diameter / pipe wall thickness diagram

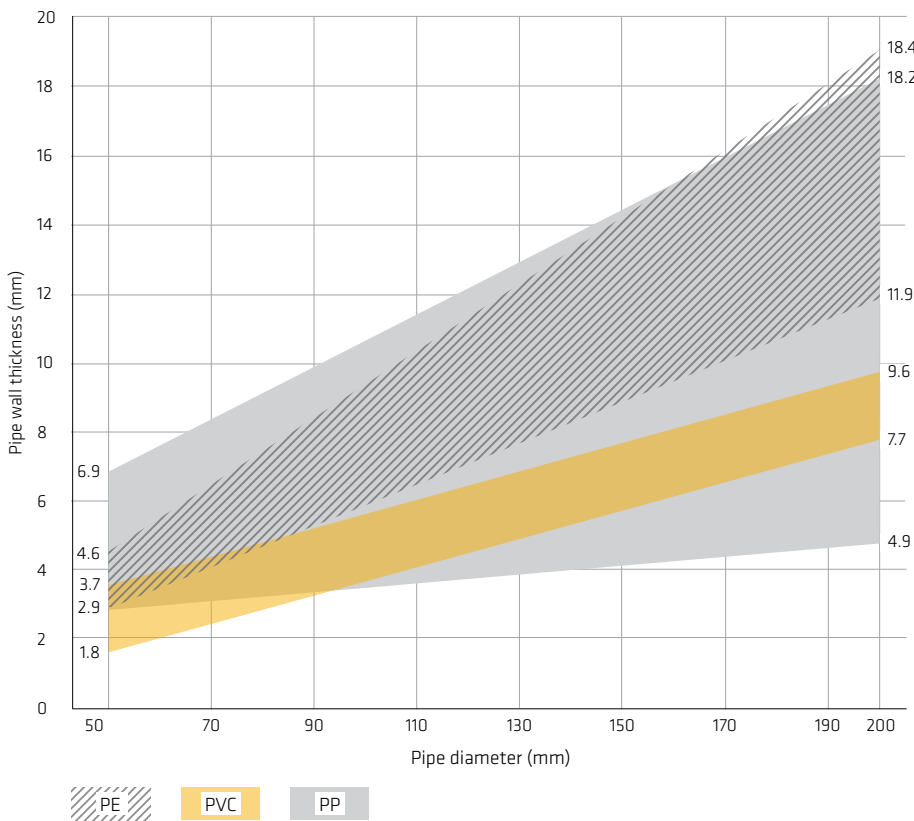

INSTALLATION INSTRUCTIONS

Refer to the relevant Sika method statement(s)

Pipe diameter (mm)	Annular space (mm)	Numbers of layers of SikaSeal®-629 Fire Wrap
32 - 50	4	1
50 - 82	6	2
82 - 115	8	3
115 - 160	10	4
160 - 200	12	5
200 - 250	14	6

Layout: 626.13/626.1

PLASTIC PIPES IN RIGID WALLS

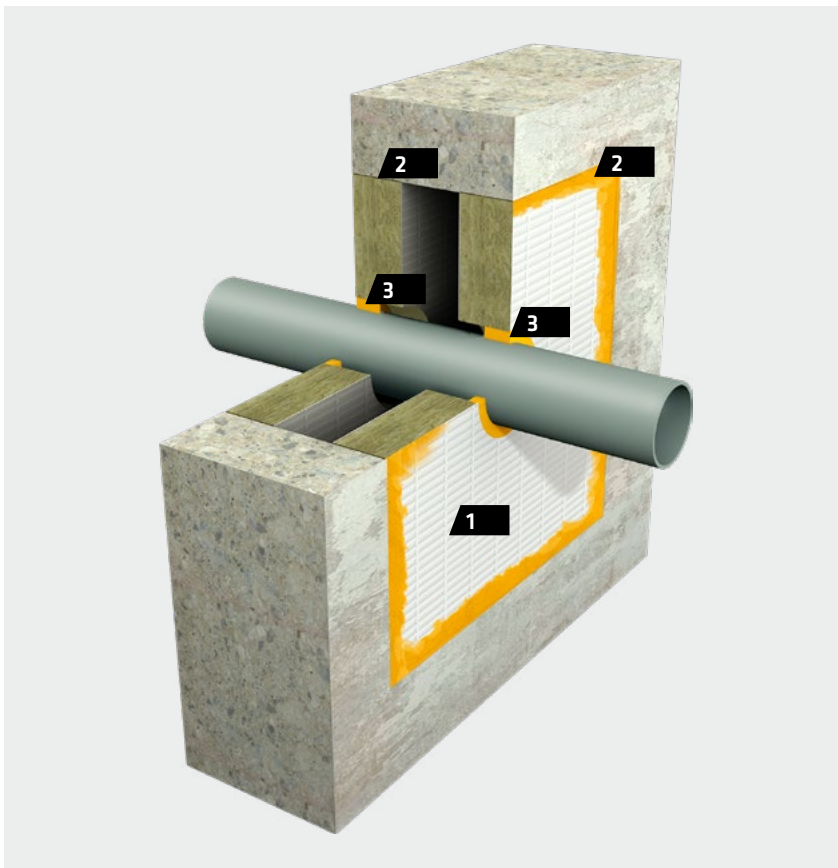

PRODUCTS, MATERIALS

1. SikaSeal®-626 Fire Board
2. Sikacryl®-621 Fire
3. SikaSeal®-623 Fire

CLASSIFICATION

EI 90 U/C

DETAILS

- Wall: Thickness ≥ 150 mm, aerated concrete, concrete or brickwork, density ≥ 760 kg/m³
- Pipe details see diagram below
- SikaSeal®-626 Fire Board internal fit, installed flush on both sides of the wall or centred in the middle of it
- 20 mm annular space around pipes sealed with SikaSeal®-623 Fire, ≥ 25 mm deep on both sides
- Sikacryl®-621 Fire between board and concrete
- Aperture size $\leq 750 \times 1,100$ mm
- Distance between pipes (sealant) ≥ 50 mm
- Distance between aperture edge and pipes (sealant) ≥ 50 mm
- Distance between wall and pipe support ≤ 400 mm

INSTALLATION INSTRUCTIONS

Refer to the relevant Sika method statement(s)

Pipe diameter / pipe wall thickness diagram

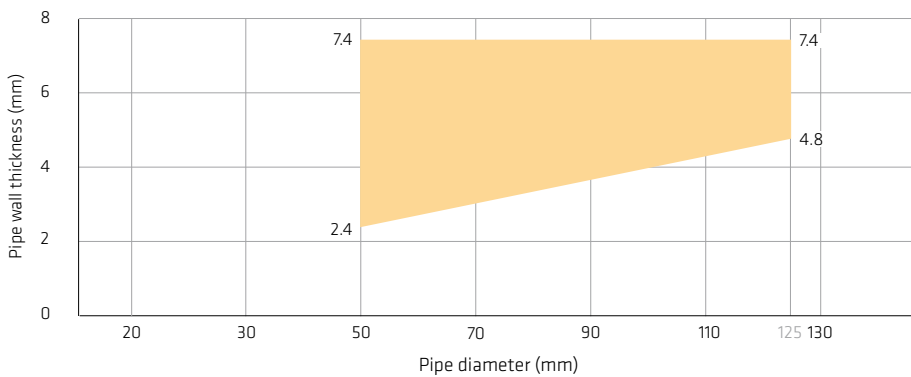

PVC

Layout: 626.14/626.J

MLC PIPES IN RIGID WALLS

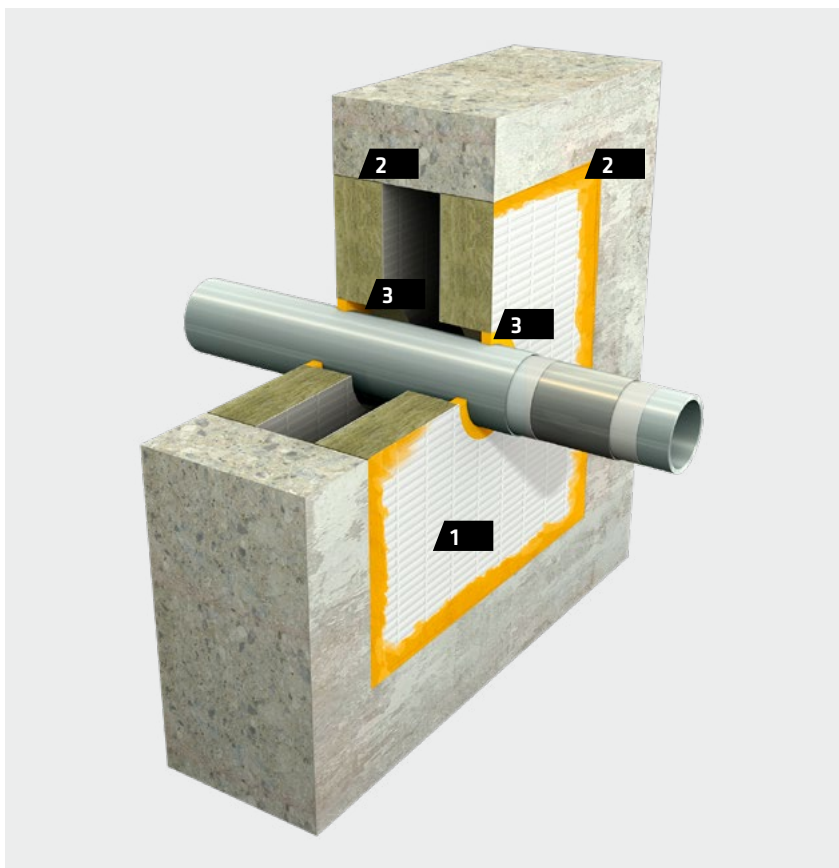

PRODUCTS, MATERIALS

1. SikaSeal®-626 Fire Board
2. Sikacryl®-621 Fire
3. SikaSeal®-623 Fire

CLASSIFICATION

EI 120 U/C

DETAILS

- Wall: Thickness ≥ 150 mm, aerated concrete, concrete or brickwork, density ≥ 760 kg/m³
- Pipe details see table below
- SikaSeal®-626 Fire Board internal fit, installed flush on both sides of the wall or centred in the middle of it
- 20 mm annular space around pipes sealed with SikaSeal®-623 Fire, 50 mm deep on both sides
- Sikacryl®-621 Fire between board and concrete
- Aperture size $\leq 750 \times 1,100$ mm
- Distance between pipes (sealant) ≥ 50 mm
- Distance between aperture edge and pipes (sealant) ≥ 50 mm
- Distance between wall and pipe support ≤ 400 mm

INSTALLATION INSTRUCTIONS

Refer to the relevant Sika method statement(s)

Penetration specification	Diameter (mm)	Wall thickness (mm)
Uponore MLC* Pipe	40	4
Uponore MLC* Pipe	50	4.5
Uponore MLC* Pipe	63	6
Uponore MLC* Pipe	75	7.5
Uponore MLC* Pipe	90	8.5
Uponore MLC* Pipe	110	10

*Multi Layer Composite

CABLES, CABLE TRAYS AND CONDUITS IN WALLS, LARGE APERTURES

Short description	Products	Code	Page
Cables, cable trays and conduits in flexible and rigid walls Insulated walls, lined apertures Internal fit board installation	SikaSeal®-626 Fire Board Sikacryl®-621 Fire	626.9	55
Cables, cable trays and conduits in flexible and rigid walls Insulated and uninsulated walls, lined and unlined apertures Face fit (pattress fit) board installation	SikaSeal®-626 Fire Board Sikacryl®-621 Fire Sikacryl®-625 Fire (Sikacryl®-621 Fire alternatively) Insulation material	626.12	56
Cable trays in rigid walls Internal fit board installation	SikaSeal®-623 Fire SikaSeal®-626 Fire Board Sikacryl®-621 Fire Sikacryl®-625 Fire	623.4	57
Cables and conduits in flexible and rigid walls Insulated walls, lined and unlined apertures	Sikacryl®-621 Fire Backing material	621.3	58

CABLES, CABLE TRAYS AND CONDUITS IN FLEXIBLE AND RIGID WALLS

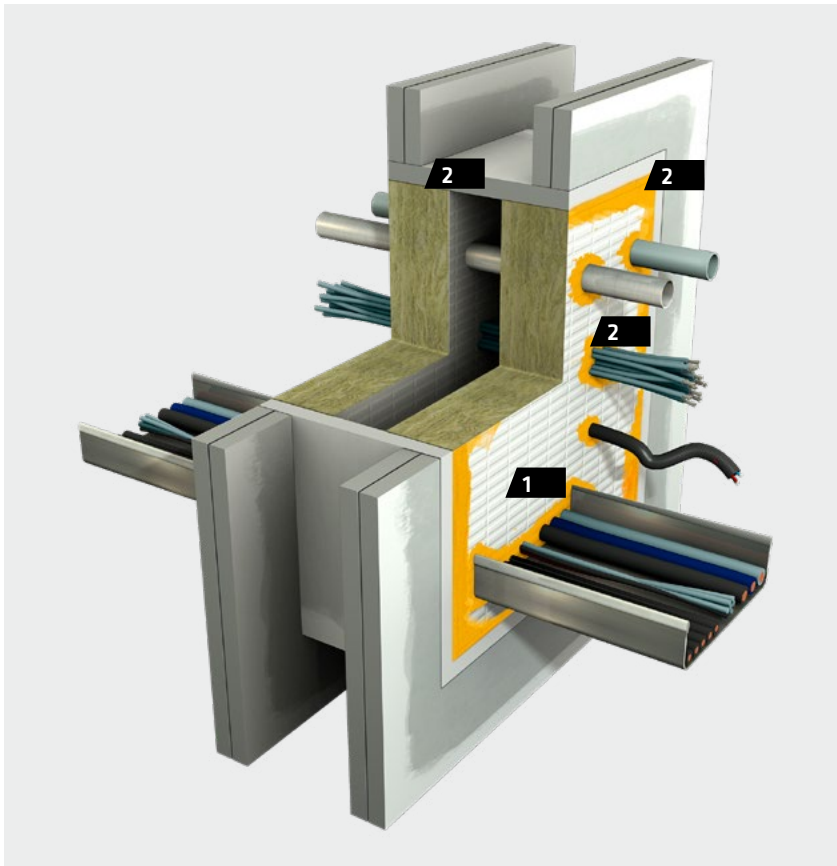

PRODUCTS, MATERIALS

1. SikaSeal®-626 Fire Board
2. Sikacryl®-621 Fire

CLASSIFICATION

See table below

DETAILS

- Wall: Thickness ≥ 100 mm, ≥ 2 layers of gypsum board each side (≥ 25 mm in total each side) on a steel or timber stud
- Cables/conduits details see table below
- Covers perforated and unperforated cable trays as well as leathers, width ≤ 500 mm
- SikaSeal®-626 Fire Board internal fit, installed flush on both sides of the wall
- Sikacryl®-621 Fire between abutting materials
- Aperture size $\leq 730 \times 1,200$ mm
- Distance between cables/cable trays/conduits ≥ 50 mm
- Distance between aperture edge and cables/cable trays/conduits ≥ 50 mm
- Distance between wall and cable, cable tray support ≤ 250 mm
- Covers flexible walls (insulated, lined) as well as rigid walls

Penetration specification	Classification
Electrical cables, diameter ≤ 21 mm	EI 60
Electrical cables, diameter 22 – 80 mm	EI 45, E 60
Cable trays and ladders	EI 60
Cable bunches, diameter ≤ 100 mm, diameter of individual cables ≤ 21 mm	EI 60
Unsheathed electrical cables, diameter ≤ 17 mm	EI 30, E 60
Unsheathed electrical cables, diameter 18 – 24 mm	EI 15, E 60
Steel and copper conduits, diameter ≤ 16 mm	EI 15, E 60
Plastic conduits, diameter ≤ 16 mm	EI 60

INSTALLATION INSTRUCTIONS

Refer to the relevant Sika method statement(s)

CABLES, CABLE TRAYS AND CONDUITS IN FLEXIBLE AND RIGID WALLS

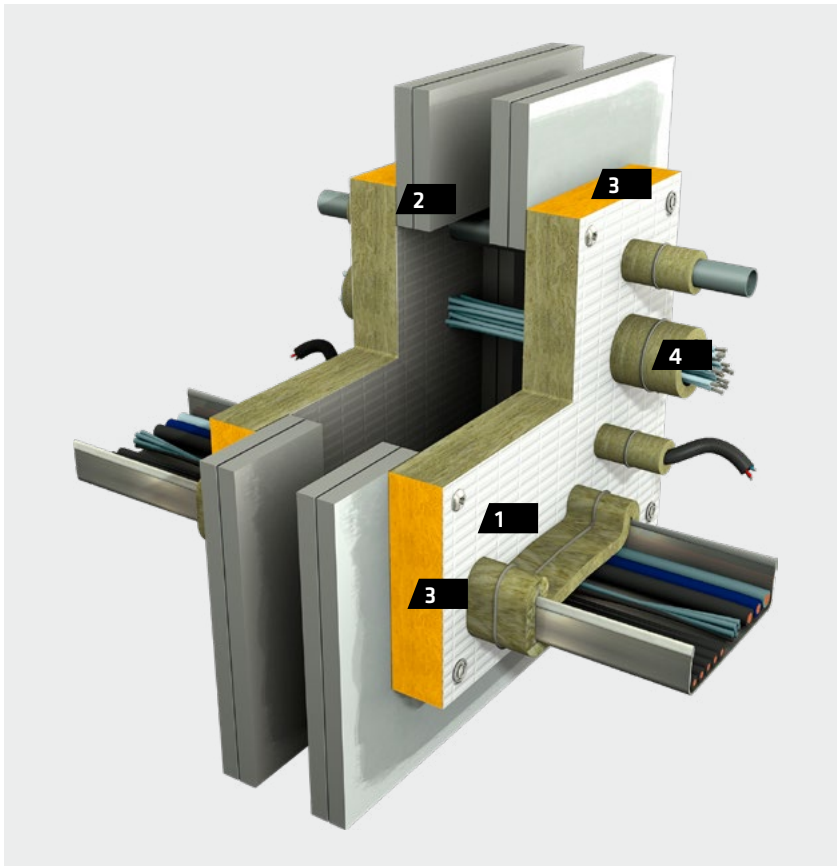

Penetration specification

Electrical cables, diameter ≤ 80 mm

Cable trays and ladders (perforated and unperforated, width ≤ 500 mm) loaded with the following cables

Cable bunches, diameter ≤ 100 mm, diameter of individual cables ≤ 21 mm

Unsheathed electrical cables, diameter ≤ 24 mm

Steel and copper conduits, diameter ≤ 16 mm

Plastic conduits, diameter ≤ 16 mm

PRODUCTS, MATERIALS

1. SikaSeal®-626 Fire Board
2. Sikacryl®-621 Fire
3. Sikacryl®-625 Fire
(Sikacryl®-621 Fire alternatively)
4. Insulation material

CLASSIFICATION

EI 120

DETAILS

- Wall: Thickness ≥ 100 mm, ≥ 2 layers of gypsum board each side (≥ 25 mm in total each side) on a steel or timber stud
- Cables/conduits details see table below
- Insulation: Stone wool or ceramic wool, density ≥ 45 kg/m³, thickness ≥ 40 mm, length ≥ 300 mm, both sides, LI (local interrupted)
- SikaSeal®-626 Fire Board face fit (pattress fit) installed on both sides of the wall
- Edge surfaces of boards coated with Sikacryl®-625 Fire or Sikacryl®-621 Fire
- Overlap between board and wall ≥ 100 mm
- Sikacryl®-621 Fire between abutting materials
- Aperture size $\leq 730 \times 1,200$ mm
- Distance between cables/cable trays/conduits (insulation) ≥ 50 mm
- Distance between aperture edge and cables/cable trays/conduits (insulation) ≥ 50 mm
- Distance between wall and cable, cable tray support ≤ 400 mm
- Covers flexible walls (insulated and uninsulated, lined and unlined) as well as rigid walls

INSTALLATION INSTRUCTIONS

Refer to the relevant Sika method statement(s)

Layout: 626.12/626.H

CABLE TRAYS IN RIGID WALLS

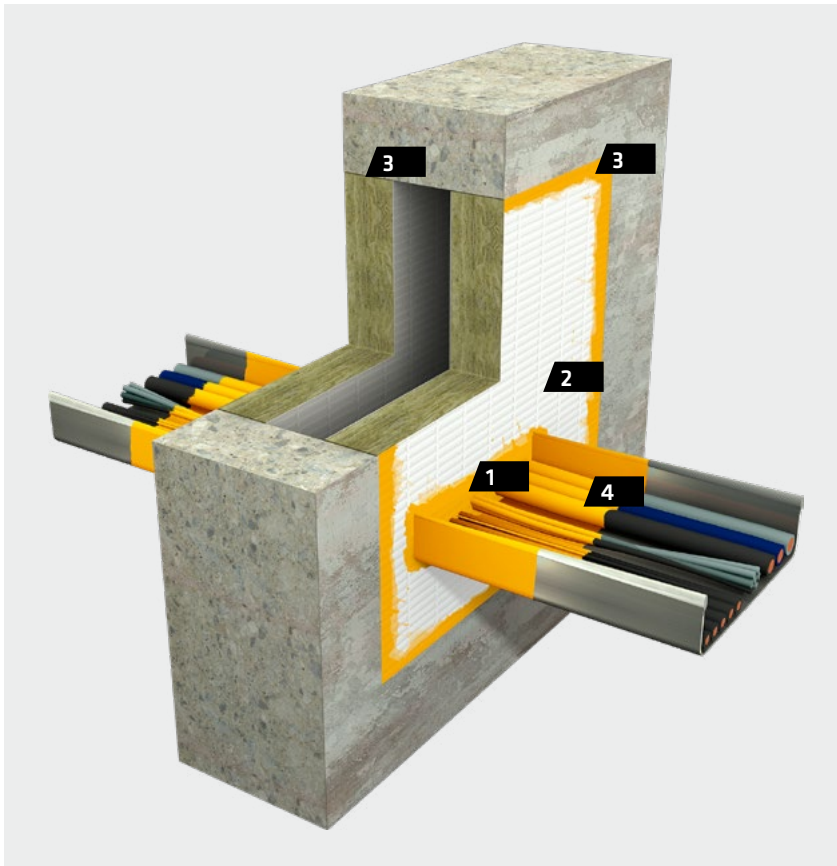

PRODUCTS, MATERIALS

1. SikaSeal®-623 Fire
2. SikaSeal®-626 Fire Board
3. Sikacryl®-621 Fire
4. Sikacryl®-625 Fire

CLASSIFICATION

See table below

DETAILS

- Wall: Thickness ≥ 150 mm, aerated concrete, concrete or brickwork, density ≥ 760 kg/m³
- SikaSeal®-626 Fire Board internal fit, installed flush on both sides of the wall or centred in the middle of it
- Cables, cable tray details see table below
- Coating: Cables and cable trays coated with Sikacryl®-625 Fire on both sides of the wall. Length ≥ 300 mm, DFT (dry film thickness) ≥ 2 mm
- 20 mm space on top of cables sealed with SikaSeal®-623 Fire, 25 mm deep on both sides
- Sikacryl®-621 Fire between abutting materials
- Aperture size $\leq 750 \times 1,100$ mm
- Distance between cable trays ≥ 100 mm
- Distance between aperture edge and cable trays ≥ 50 mm
- Distance between wall and cable tray support ≤ 200 mm

INSTALLATION INSTRUCTIONS

Refer to the relevant Sika method statement(s)

Penetration specification	Classification
Cable trays and ladders (perforated and unperforated, width ≤ 500 mm) loaded with the following cables	EI 120
Electrical cables, diameter ≤ 21 mm	EI 120
"C1 cable" acc. EN 1366-3	EI 120
"C2 cable" acc. EN 1366-3	EI 90, E 120
"C3 cable" acc. EN 1366-3	EI 120

CABLES, CABLE BUNDLES AND CONDUITS IN FLEXIBLE AND RIGID WALLS

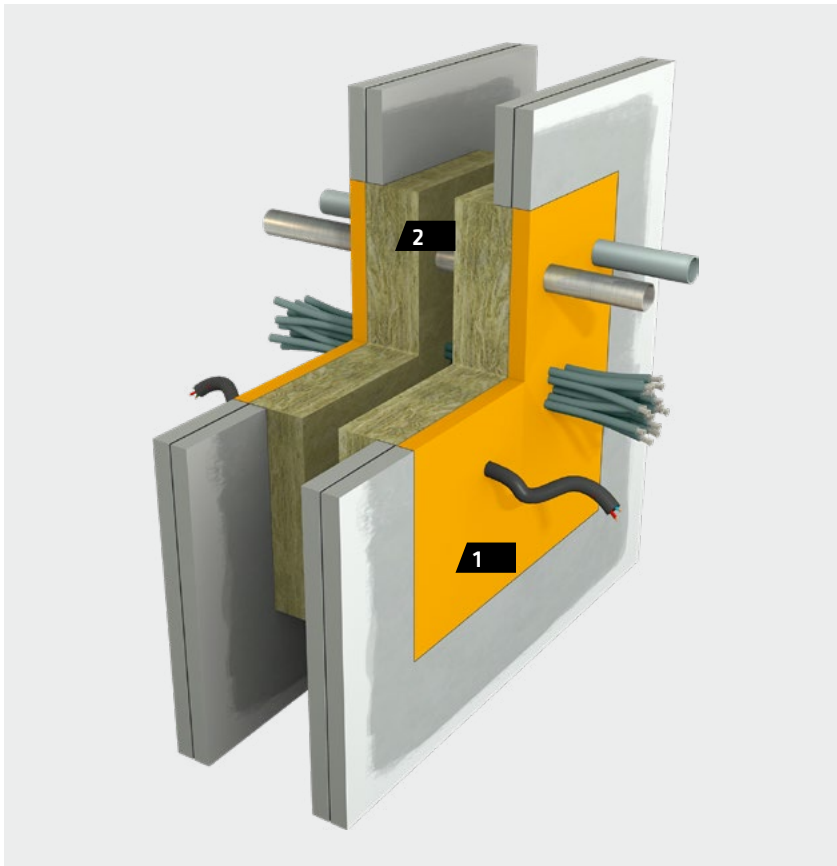

PRODUCTS, MATERIALS

1. Sikacryl®-621 Fire
2. Backing material

CLASSIFICATION

See table below

DETAILS

- Wall: Thickness ≥ 100 mm, ≥ 2 layers of gypsum board each side (≥ 25 mm in total each side) on a steel or timber stud
- Cables/conduits details see table below
- Backing material: Stone wool or ceramic wool, density ≥ 45 kg/m³, thickness ≥ 20 mm, same dimension as aperture, applied on both sides of the wall (internal fit)
- Sikacryl®-621 Fire ≥ 20 mm deep on backing material
- Aperture size 50 x 50 – 180 x 180 mm or round with same diameter restrictions
- Distance between cables/cable trays/conduits ≥ 0 mm
- Distance between aperture edge and cables/cable trays/conduits ≥ 10 mm
- Distance between wall and cable, conduit support ≤ 400 mm
- Covers flexible walls (insulated, lined and unlined) as well as rigid walls

INSTALLATION INSTRUCTIONS

Refer to the relevant Sika method statement(s)

Penetration specification	Classification
Electrical cables, diameter ≤ 50 mm	EI 60, E 90
Cable bunches, diameter ≤ 100 mm, diameter of individual cables ≤ 21 mm	EI 120, E 90
Steel and copper conduits, diameter ≤ 16 mm	EI 20, E 120
Plastic conduits, diameter ≤ 16 mm	EI 120

Layout: 621.3/621.C

INSULATED METAL PIPES IN WALLS, SMALL APERTURES

Short description	Products	Code	Page
Insulated steel and copper pipes in flexible and rigid walls Armaflex AF foam pipe insulation Insulated walls, lined and unlined apertures	SikaSeal®-623 Fire	623.1	61
Insulated steel and copper pipes in flexible and rigid walls Armaflex AF foam pipe insulation Insulated walls, lined and unlined apertures	SikaSeal®-623 Fire	623.2	62

INSULATED METAL PIPES IN FLEXIBLE AND RIGID WALLS



PRODUCTS, MATERIALS

1. SikaSeal®-623 Fire

CLASSIFICATION

See table below

DETAILS

- Wall: Thickness ≥ 120 mm, ≥ 2 layers of gypsum board each side (≥ 25 mm in total each side) on a steel or timber stud
- Pipes: Steel and copper or metals with higher melting point and/or lower thermal conductivity, details see table below
- Pipe insulation: Armaflex AF foam insulation, CS (continuous sustained)
- Core drilled holes, 20 mm annular space around pipes
- Sikacryl®-623 Fire ≥ 25 mm deep on both sides
- Distance between pipes (sealant) ≥ 100 mm
- Covers flexible walls (insulated, lined and unlined) as well as rigid walls
- Distance between wall and pipe support ≤ 150 mm

INSTALLATION INSTRUCTIONS

Refer to the relevant Sika method statement(s)

Pipe diameter (mm)	Pipe wall thickness (mm)	Pipe insulation thickness (mm)	Classification
60	0.8 - 14.2	32	EI 90 C/U
15	0.8 - 7.0	13	EI 120 C/U

INSULATED METAL PIPES IN FLEXIBLE AND RIGID WALLS



PRODUCTS, MATERIALS

1. SikaSeal®-623 Fire

CLASSIFICATION

See table below

DETAILS

- Wall: Thickness ≥ 100 mm, ≥ 2 layers of gypsum board each side (≥ 25 mm in total each side) on a steel or timber stud
- Pipes: Steel and copper or metals with higher melting point and/or lower thermal conductivity, details see table below
- Pipe insulation: Armaflex AF foam insulation, CS (continuous sustained)
- Core drilled holes, 20 mm annular space around pipes
- Sikacryl®-623 Fire ≥ 25 mm deep on both sides
- Distance between pipes (sealant) ≥ 100 mm
- Covers flexible walls (insulated, lined and unlined) as well as rigid walls
- Distance between wall and pipe support ≤ 150 mm

INSTALLATION INSTRUCTIONS

Refer to the relevant Sika method statement(s)

Pipe diameter (mm)	Pipe wall thickness (mm)	Pipe insulation thickness (mm)	Classification
40	1.5 - 14.2	32	EI 30, E 120 C/U
40 - 159	2.0 - 14.2	32	EI 30, E 120 C/U

Layout: 623.2/623.A

UNINSULATED METAL PIPES IN WALLS, SMALL APERTURES

Short description	Products	Code	Page
Uninsulated steel pipes in flexible and rigid walls Insulated walls, lined and unlined apertures	Sikacryl®-621 Fire	621.1	65
Uninsulated steel and copper pipes in flexible and rigid walls Insulated walls, lined and unlined apertures	Sikacryl®-621 Fire Pipe insulation	621.2	66

UNINSULATED METAL PIPES IN FLEXIBLE AND RIGID WALLS



PRODUCTS, MATERIALS

1. Sikacryl®-621 Fire

CLASSIFICATION

EI 45 C/U for pipes ≤ 42 mm diameter

EI 20, **E 120 C/U** for all other pipes

DETAILS

- Wall: Thickness ≥ 100 mm, ≥ 2 layers of gypsum board each side (≥ 25 mm in total each side) on a steel or timber stud
- Pipes: Diameter ≤ 114 mm, wall thickness 3 – 14.2 mm, steel or metals with higher melting point and/or lower thermal conductivity
- Core drilled holes, ≤ 10 mm annular space around pipes
- Sikacryl®-621 Fire ≥ 25 mm deep on both sides
- Distance between sealant ≥ 100 mm
- Distance between wall and pipe support ≤ 400 mm
- Covers flexible walls (insulated, lined and unlined) as well as rigid walls

INSTALLATION INSTRUCTIONS

Refer to the relevant Sika method statement(s)

UNINSULATED METAL PIPES IN FLEXIBLE AND RIGID WALLS

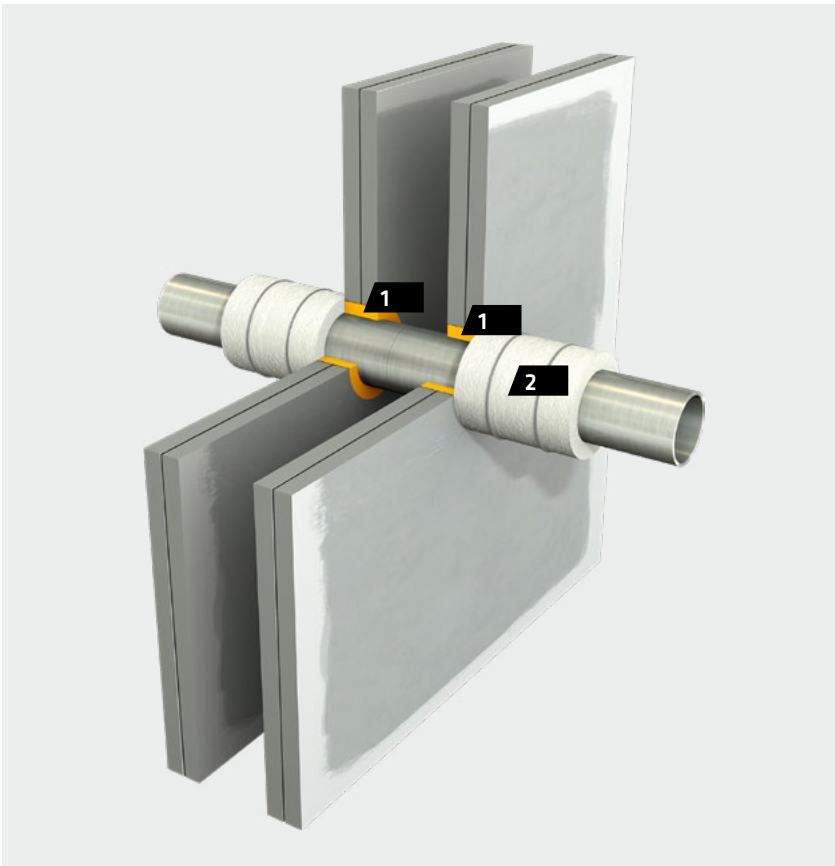

PRODUCTS, MATERIALS

1. Sikacryl®-621 Fire
2. Pipe insulation

CLASSIFICATION

EI 90 C/U for pipes ≤ 40 mm diameter

EI 20, **E 120 C/U** for all other pipes

DETAILS

- Wall: Thickness ≥ 120 mm, ≥ 2 layers of gypsum board each side (≥ 25 mm in total each side) on a steel or timber stud
- Pipes: Diameter ≤ 159 mm, wall thickness 1.8 – 14.2 mm, steel and copper or metals with higher melting point and/or lower thermal conductivity
- Pipe insulation: ceramic wool, density ≥ 160 kg/m³, thickness ≥ 6 mm, length ≥ 300 mm, both sides of the wall, LI (local interrupted)
- Core drilled holes, ≤ 10 mm annular space around pipes
- Sikacryl®-621 Fire ≥ 25 mm deep on both sides
- Distance between insulation ≥ 100 mm
- Distance between wall and pipe support ≤ 150 mm
- Covers flexible walls (insulated, lined and unlined) as well as rigid walls

INSTALLATION INSTRUCTIONS

Refer to the relevant Sika method statement(s)

PLASTIC AND MLC PIPES IN WALLS, SMALL APERTURES

Short description	Products	Code	Page
Plastic pipes in flexible and rigid walls Pipes U/C Insulated and uninsulated walls, lined and unlined apertures	SikaSeal®-627 Fire Collar Sikacryl®-621 Fire	627.4	69
Plastic pipes in flexible and rigid walls Pipes U/U Insulated and uninsulated walls, lined and unlined apertures	SikaSeal®-627 Fire Collar Sikacryl®-621 Fire	627.8	70
Angled plastic pipes in flexible and rigid walls Insulated and uninsulated walls, lined and unlined apertures	SikaSeal®-627 Fire Collar Sikacryl®-621 Fire	627.9	71
Plastic pipes in flexible and rigid walls Insulated walls, lined and unlined apertures	SikaSeal®-623 Fire	623.3	72
Plastic pipes in flexible and rigid walls Insulated walls, lined and unlined apertures	SikaSeal®-628 Fire Wrap (SikaSeal®-629 Fire Wrap alternatively) Sikacryl®-621 Fire	628.2	73

PLASTIC PIPES IN FLEXIBLE AND RIGID WALLS

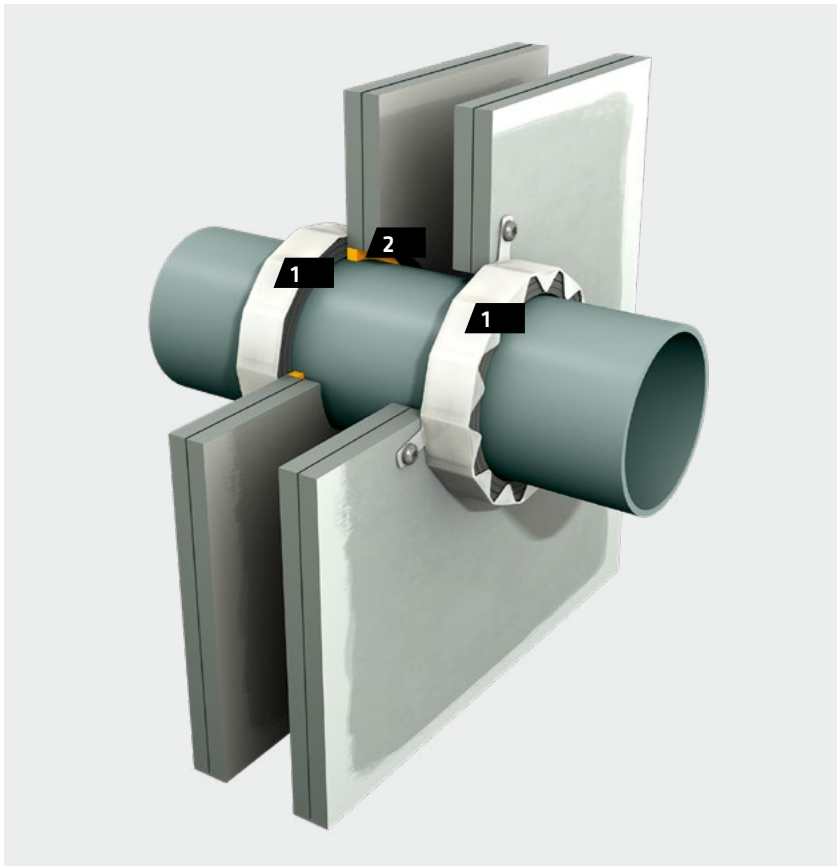

PRODUCTS, MATERIALS

1. SikaSeal®-627 Fire Collar
2. Sikacryl®-621 Fire

CLASSIFICATION

EI 120 U/C for all pipes, see diagram below

DETAILS

- Wall: Thickness ≥ 100 mm, ≥ 2 layers of gypsum board each side (≥ 25 mm in total each side) on a steel or timber stud
- Pipe details see diagram below
- Core drilled holes, ≤ 10 mm annular space around pipes
- Sikacryl®-621 Fire ≥ 12.5 mm deep on both sides
- SikaSeal®-627 Fire Collar on both sides
- Distance between collars ≥ 100 mm
- Distance between wall and pipe support ≤ 400 mm
- Covers flexible walls (insulated and uninsulated, lined and unlined) as well as rigid walls

INSTALLATION INSTRUCTIONS

Refer to the relevant Sika method statement(s)

Pipe diameter, collar diameter (mm)	PVC*	PP	PE**
	Pipe wall thickness (mm)		
32	1.8	2.9	2.9
40	1.8	2.9	2.9
50	1.8	2.9	2.9
55	2.3 - 3.0	2.9 - 4.4	2.9 - 4.4
63	2.3 - 3.0	2.9 - 4.4	2.9 - 4.4
75	3.1 - 4.8	2.8 - 6.7	2.8 - 6.7
82	3.1 - 4.8	2.8 - 6.7	2.8 - 6.7
90	4.2 - 7.4	2.7 - 10.0	2.7 - 10.0
100	4.2 - 7.4	2.7 - 10.0	2.7 - 10.0
110	4.2 - 7.4	2.7 - 10.0	2.7 - 10.0
125	6	3.1	3.1
140	6.1 - 7.5	3.5 - 8.0	3.9 - 5.8
160	6.2 - 9.5	4.0 - 14.6	4.9 - 9.5

* PVC-U, PVC-C

** PE HD, ABS, SAN + PVC

See chapter "Pipe and insulation material"

Layout: 627.4/627.D

PLASTIC PIPES IN FLEXIBLE AND RIGID WALLS

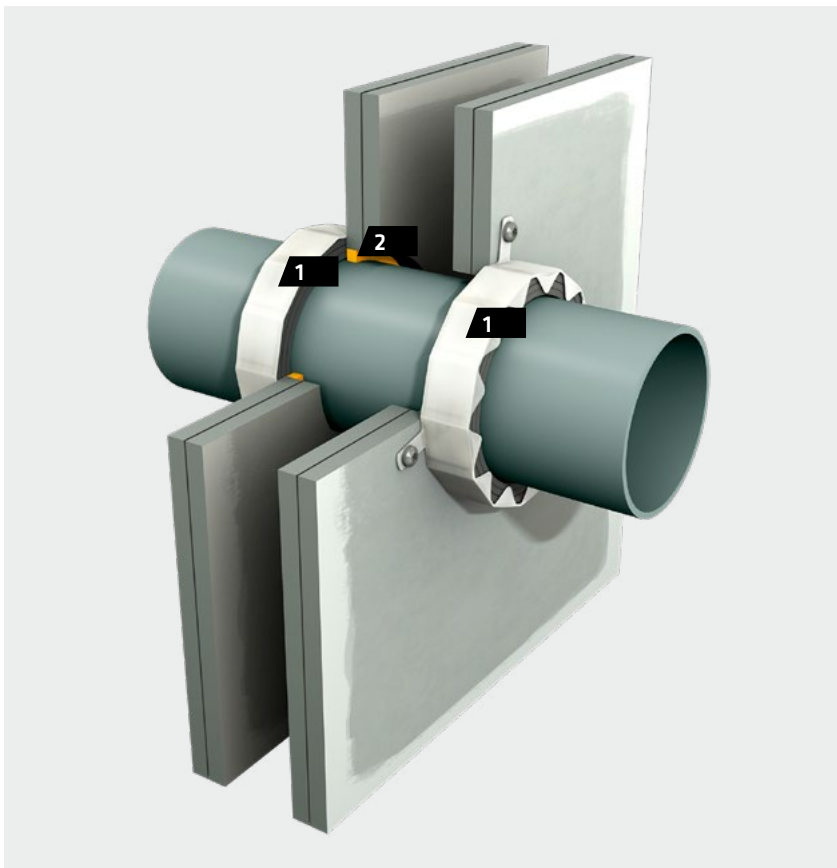

PRODUCTS, MATERIALS

1. SikaSeal®-627 Fire Collar
2. Sikacryl®-621 Fire

CLASSIFICATION

EI 60 U/U for all pipes, see diagram below

DETAILS

- Wall: Thickness ≥ 100 mm, ≥ 2 layers of gypsum board each side (≥ 25 mm in total each side) on a steel or timber stud
- Pipe details see diagram below
- Core drilled holes, ≤ 10 mm annular space around pipes
- Sikacryl®-621 Fire ≥ 12.5 mm deep on both sides
- SikaSeal®-627 Fire Collar on both sides
- Distance between collars ≥ 100 mm
- Distance between wall and pipe support ≤ 400 mm
- Covers flexible walls (insulated and uninsulated, lined and unlined) as well as rigid walls

INSTALLATION INSTRUCTIONS

Refer to the relevant Sika method statement(s)

Pipe diameter, collar diameter (mm)	PVC*	PP	PE**
	Pipe wall thickness (mm)		
32	1.8 - 3.7	2.0 - 6.9	3.1 - 4.6
40	1.8 - 3.7	2.0 - 6.9	3.1 - 4.6
50	1.8 - 3.7	2.0 - 6.9	3.1 - 4.6
55	2.2 - 4.3	2.1 - 7.5	3.0 - 5.7
63	2.2 - 4.3	2.1 - 7.5	3.0 - 5.7
75	3.2 - 5.2	2.3 - 8.5	2.9 - 7.4
82	3.2 - 5.2	2.3 - 8.5	2.9 - 7.4
90	4.2 - 6.6	2.7 - 10.0	2.7 - 10.0
100	4.2 - 6.6	2.7 - 10.0	2.7 - 10.0
110	4.2 - 6.6	2.7 - 10.0	2.7 - 10.0
125	4.8 - 7.4	3.1 - 17.1	3.1 - 11.4
140	5.4 - 8.3	3.5 - 11.5	3.4 - 10.5
160	6.2 - 9.5	4.0 - 14.6	4.0 - 9.5

* PVC-U, PVC-C

** PE HD, ABS, SAN + PVC

See chapter "Pipe and insulation material"

Layout: 627.8/627.D

ANGLED PLASTIC PIPES IN FLEXIBLE AND RIGID WALLS

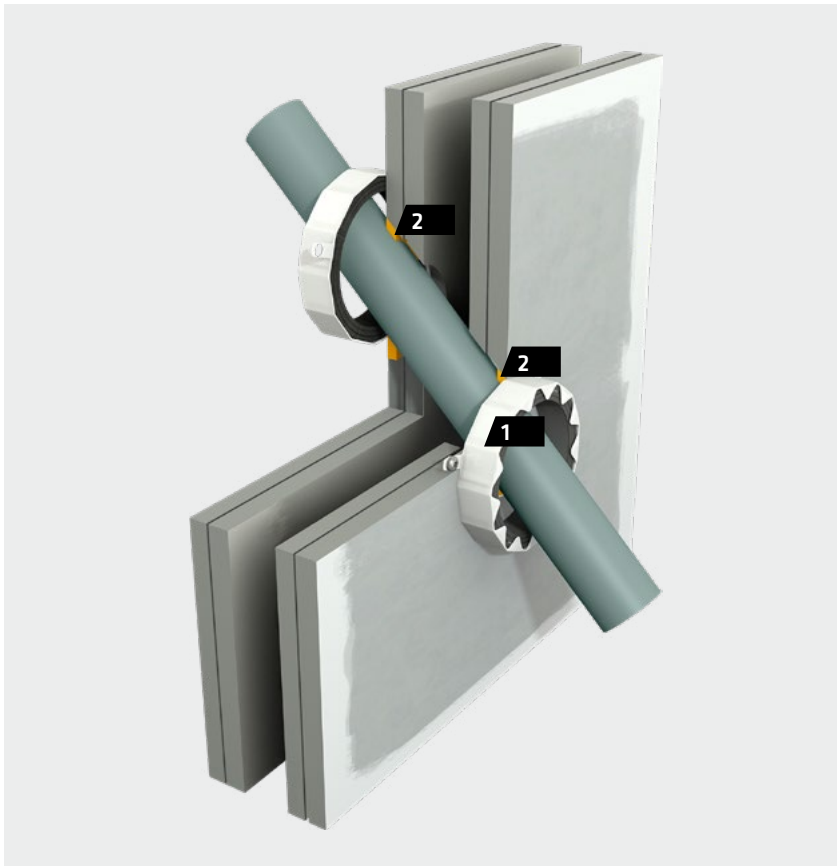

PRODUCTS, MATERIALS

1. SikaSeal®-627 Fire Collar
2. Sikacryl®-621 Fire

CLASSIFICATION

EI 90 U/C for all pipes, see diagram below

DETAILS

- Wall: Thickness ≥ 100 mm, ≥ 2 layers of gypsum board each side (≥ 25 mm in total each side) on a steel or timber stud
- Pipe details see diagram below
- Core drilled holes, ≤ 10 mm annular space around pipes
- Sikacryl®-621 Fire ≥ 12.5 mm deep on both sides
- SikaSeal®-627 Fire Collar on both sides for collar sizes see table below.
- Distance between collars ≥ 0 mm
- Distance between wall and pipe support ≤ 400 mm
- Pipes installed at a horizontal or vertical angle of $90 - 30^\circ$ in relation to the wall surface. Pipe details see diagram below
- Covers flexible walls (insulated and uninsulated, lined and unlined) as well as rigid walls

INSTALLATION INSTRUCTIONS

Refer to the relevant Sika method statement(s)

Pipe diameter, collar diameter (mm)	PVC*	PP	PE**
	Pipe wall thickness (mm)		
32	1.8	2.9	2.9
40	1.8	2.9	2.9
50	1.8	2.9	2.9
55	2.3 - 3.0	2.9 - 4.4	2.9 - 4.4
63	2.3 - 3.0	2.9 - 4.4	2.9 - 4.4
75	3.1 - 4.8	2.8 - 6.7	2.8 - 6.7
82	3.1 - 4.8	2.8 - 6.7	2.8 - 6.7
90	4.2 - 7.4	2.7 - 10.0	2.7 - 10.0
100	4.2 - 7.4	2.7 - 10.0	2.7 - 10.0
110	4.2 - 7.4	2.7 - 10.0	2.7 - 10.0
125	6	3.1	3.1
140	6.1 - 7.5	3.5 - 8.0	3.9 - 5.8
160	6.2 - 9.5	4.0 - 14.6	4.9 - 9.5

* PVC-U, PVC-C

** PE HD, ABS, SAN + PVC

See chapter "Pipe and insulation material"

Pipe diameter (mm)	Pipe angle in relation to wall		
	75°	60°	45°
	Required collar diameter (mm)		
32	55	63	82
40	55	75	90
50	63	82	110
55	75	82	110
63	75	110	125
75	90	110	160
82	110	125	160
90	110	125	200
100	125	140	200
110	125	160	200
125	160	200	-
140	160	-	-
160	200	-	-

For pipes installed at angles different to 90° (perpendicular to wall) larger collars are required.

The above tables gives an overview to typical angles. For other angles please contact Sika Technical Service.

Layout: 627.9/627.H

PLASTIC PIPES IN FLEXIBLE AND RIGID WALLS



PRODUCTS, MATERIALS

1. SikaSeal®-623 Fire

CLASSIFICATION

See table below

DETAILS

- Wall: Thickness ≥ 100 mm, ≥ 2 layers of gypsum board each side (≥ 25 mm in total each side) on a steel or timber stud
- Pipes details see table below
- Core drilled holes, 20 mm annular space around pipes
- Sikacryl®-623 Fire ≥ 25 mm deep on both sides with a 10 mm fillet on the outer face
- Distance between pipes (sealant) ≥ 100 mm
- Distance between wall and pipe support ≤ 260 mm
- Covers flexible walls (insulated, lined and unlined) as well as rigid walls

INSTALLATION INSTRUCTIONS

Refer to the relevant Sika method statement(s)

Pipe material	Pipe diameter	Pipe wall thickness (mm)	Classification
PVC	40	1.9	EI 120 C/U
PVC	125	9.2	EI 60 C/U
ABS	40	1.9	EI 120 C/U
PP	40	2.0	EI 120 C/U

Layout: 623.3/623.B

PLASTIC PIPES IN FLEXIBLE AND RIGID WALLS



PRODUCTS, MATERIALS

1. SikaSeal®-628 Fire Wrap
(SikaSeal®-629 Fire Wrap alternatively)
2. Sikacryl®-621 Fire

CLASSIFICATION

PVC: **EI 120 U/C**

PP, PE: **EI 90 U/C**

Details see diagram below

DETAILS

- Wall: Thickness ≥ 120 mm, ≥ 2 layers of gypsum board each side (≥ 25 mm in total each side) on a steel or timber stud
- Pipe details see diagram below
- Core drilled holes, annular space around pipes see table below
- SikaSeal®-628 Fire Wrap according to pipe diameter on both sides; alternatively SikaSeal®-629 Fire Wrap according to table below on both sides
- Sikacryl®-621 Fire 5 mm deep on both sides
- Distance between pipes (wrap) ≥ 100 mm
- Distance between wall and pipe support ≤ 400 mm
- Covers flexible walls (insulated, lined and unlined) as well as rigid walls

Pipe diameter / pipe wall thickness diagram

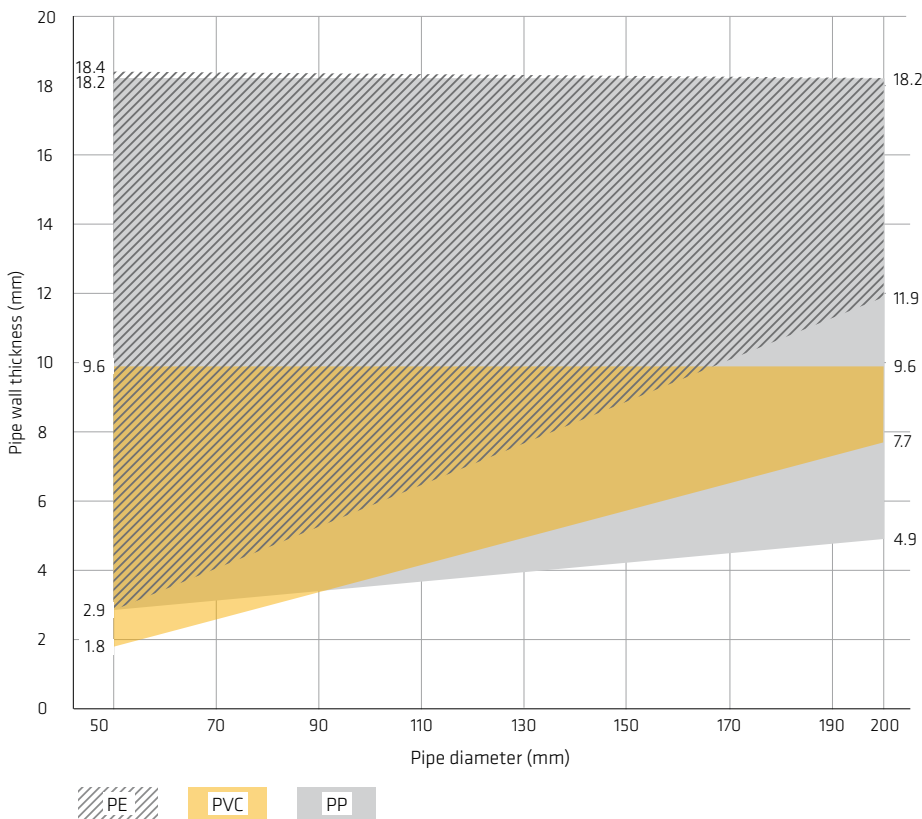

INSTALLATION INSTRUCTIONS

Refer to the relevant Sika method statement(s)

Pipe diameter (mm)	Annular space	Numbers of layers of SikaSeal®-629 Fire Wrap
32 - 50	4	1
50 - 82	6	2
82 - 115	8	3
115 - 160	10	4
160 - 200	12	5
200 - 250	14	6

Layout: 628.2/628.B

CABLES, CABLE TRAYS AND CONDUITS IN WALLS, SMALL APERTURES

Short description	Products	Code	Page
Cables and conduits in flexible and rigid walls	Sikacryl®-621 Fire	621.4	75
Insulated walls, lined and unlined apertures			

CABLES AND CONDUITS IN FLEXIBLE AND RIGID WALLS

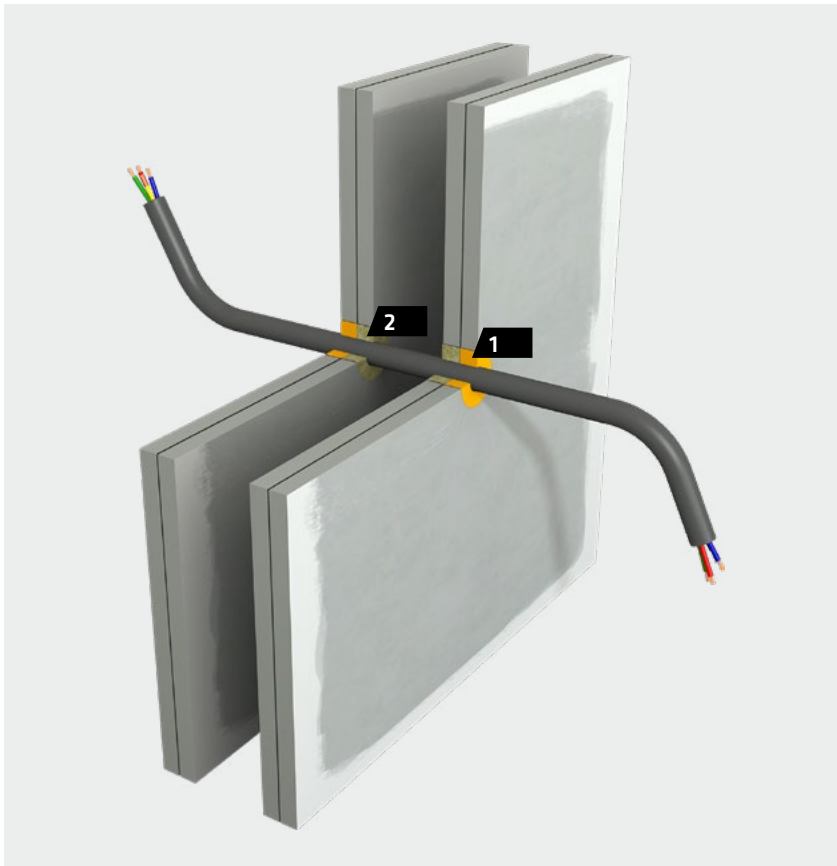

PRODUCTS, MATERIALS

1. Sikacryl®-621 Fire
2. Backing material

CLASSIFICATION

See table below

DETAILS

- Wall: Thickness ≥ 75 mm, ≥ 1 layers of gypsum board each side (≥ 12.5 mm in total each side) on a steel or timber stud
- Core drilled holes ≤ 25 mm diameter
- Sikacryl®-621 Fire ≥ 12 mm deep on both sides backed with ≥ 10 mm stone-wool, density ≥ 45 kg/m³
- Cable and conduit detail see table below
- Distance between aperture edge and cables ≥ 0 mm
- Distance between wall and cable support ≤ 980 mm
- Covers flexible walls (insulated, lined and unlined) as well as rigid walls

INSTALLATION INSTRUCTIONS

Refer to the relevant Sika method statement(s)

Penetration specification	Classification
Electrical cables, diameter 18 - 21 mm	EI 60, E 90
Copper conduits, diameter ≤ 15 mm, pipe wall thickness 0.7 mm	EI 60, E 90
Stainless steel conduits, diameter ≤ 15 mm, pipe wall thickness 1.0 mm	EI 90

UNINSULATED METAL PIPES IN FLOORS, LARGE APERTURES

Short description	Products	Code	Page
Uninsulated metal pipes in rigid floors, non-load-bearing Internal fit board installation	SikaSeal®-626 Fire Board Sikacryl®-621 Fire Pipe insulation	626.16	77
Uninsulated metal pipes in rigid floors, load-bearing	Sikacrete®-630 Fire	630.2	78

UNINSULATED METAL PIPES IN RIGID FLOORS, NON-LOAD-BEARING

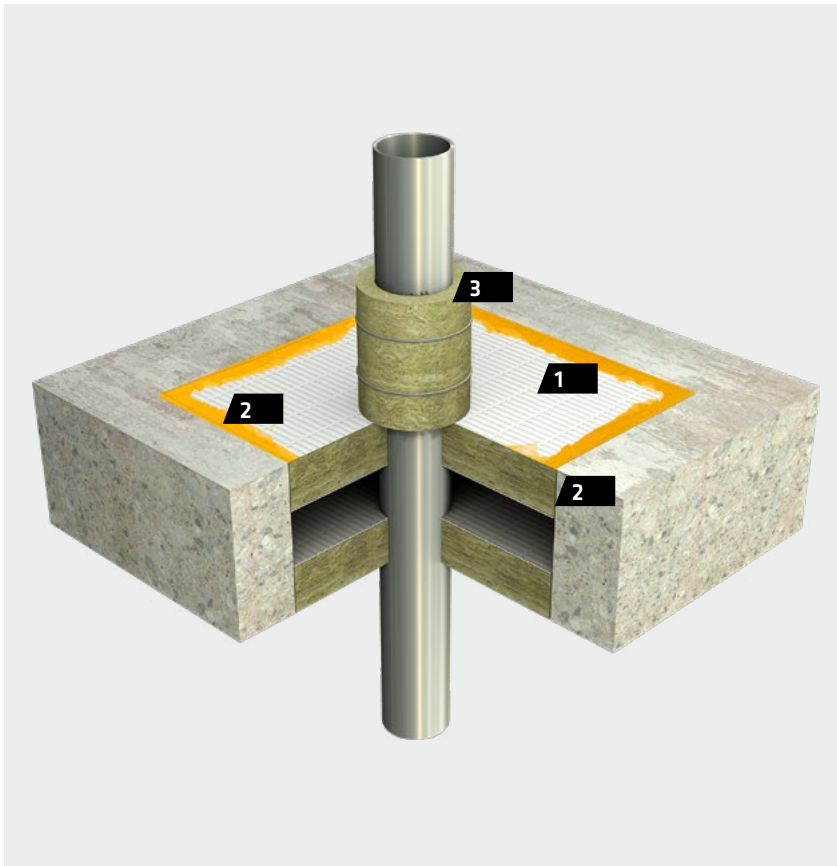

PRODUCTS, MATERIALS

1. SikaSeal®-626 Fire Board
2. Sikacryl®-621 Fire
3. Pipe insulation

CLASSIFICATION

EI 60 U/C for pipes with 42 mm diameter, 1.2 mm wall thickness

EI 30, E 60 U/C for pipes ≤ 159 mm diameter

DETAILS

- Floor: Thickness ≥ 150 mm, aerated concrete, concrete or brickwork, density ≥ 670 kg/m³
- SikaSeal®-626 Fire Board internal fit, installed flush on the upper side of the floor or centred in the middle of it
- Pipes: diameter ≤ 159 mm, wall thickness 2.0 – 14.2 mm steel and copper or metals with higher melting point and/or lower thermal conductivity
- Pipe insulation: Stone wool or ceramic wool, density ≥ 45 kg/m³, thickness ≥ 40 mm, length ≥ 300 mm, upper sides of the floor, LI (local interrupted)
- Sikacryl®-621 Fire between abutting materials
- Aperture size $\leq 700 \times 1,600$ mm
- Distance between pipes (insulation) ≥ 50 mm
- Distance between aperture edge and pipes (insulation) ≥ 50 mm
- Distance between floor and pipe support ≤ 400 mm (upper side only)

INSTALLATION INSTRUCTIONS

Refer to the relevant Sika method statement(s)

UNINSULATED METAL PIPES IN RIGID FLOORS, LOAD-BEARING

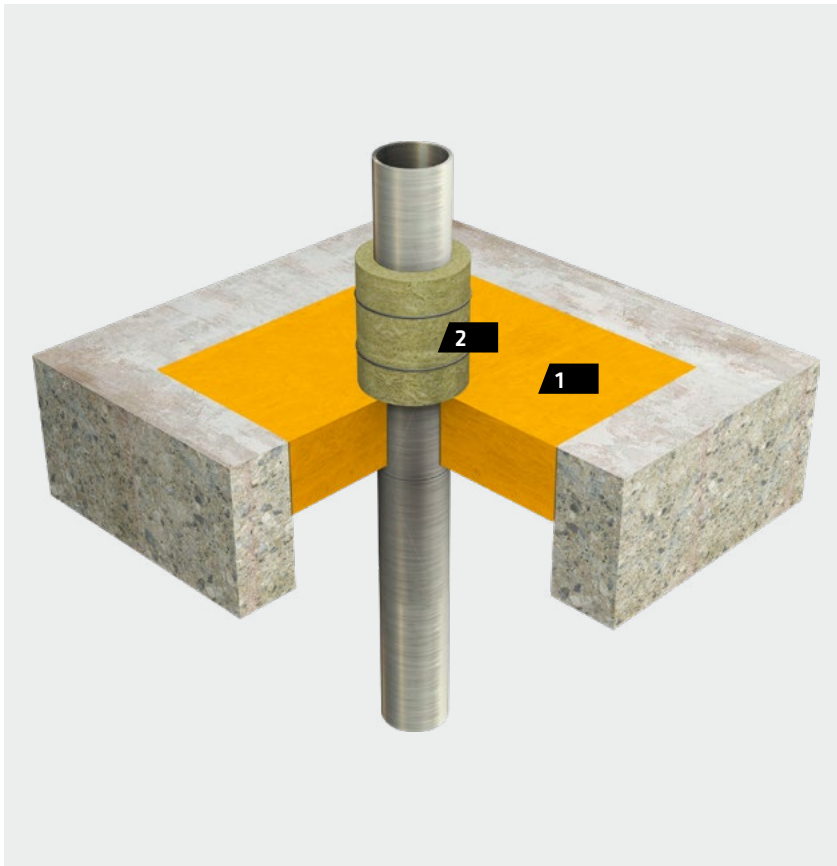

PRODUCTS, MATERIALS

1. Sikacrete®-630 Fire
2. Insulation material

CLASSIFICATION

See table below

DETAILS

- Floor: Thickness ≥ 150 mm, aerated concrete, concrete or brickwork, density ≥ 670 kg/m³
- Pipe details see table below
- Insulation: Stone wool or ceramic wool, density ≥ 150 kg/m³, thickness ≥ 50 mm, length ≥ 500 mm on the upper side of the floor, LI (locally interrupted)
- Sikacrete®-630 Fire: ≥ 100 mm thick, flush on the upper side of the floor
- Aperture size $\leq 1,800 \times 1,800$ mm
- Sikacrete®-630 Fire: ≥ 100 mm thick, flush on upper side of the floor
- Distance between cable, pipes ≥ 100 mm
- Distance between aperture edge and cable trays ≥ 100 mm
- Distance between floor and pipe support ≤ 150 mm (upper side only)

INSTALLATION INSTRUCTIONS

Refer to the relevant Sika method statement(s)

Pipe specification	Classification
Copper pipes, diameter 40 - 107 mm, wall thickness 1.5 - 14.2 mm	EI 15, E 60 C/U
Steel pipes, diameter 40 - 115 mm, wall thickness 3.0 - 14.2 mm	EI 120 C/U
Steel pipes, diameter 40 - 160 mm, wall thickness 3.0 - 14.2 mm	EI 90 C/U

Layout: 630.2/630.B

PLASTIC AND MLC PIPES IN FLOORS, LARGE APERTURES

Short description	Products	Code	Page
Plastic pipes in rigid floors, load-bearing	SikaSeal®-627 Fire Collar Sikacrete®-630 Fire	627.2	81
Plastic pipes in rigid floors, non-load-bearing Internal fit board installation	SikaSeal®-626 Fire Board Sikacryl®-621 Fire SikaSeal®-627 Fire Collar	627.3	82
Plastic pipes in rigid floors, non-load-bearing Internal fit board installation	SikaSeal®-626 Fire Board SikaSeal®-623 Fire Sikacryl®-621 Fire	626.18	83
MLC pipes in rigid floors, non-load-bearing Internal fit board installation	SikaSeal®-626 Fire Board SikaSeal®-623 Fire Sikacryl®-621 Fire	626.19	84

PLASTIC PIPES IN RIGID FLOORS, LOAD-BEARING

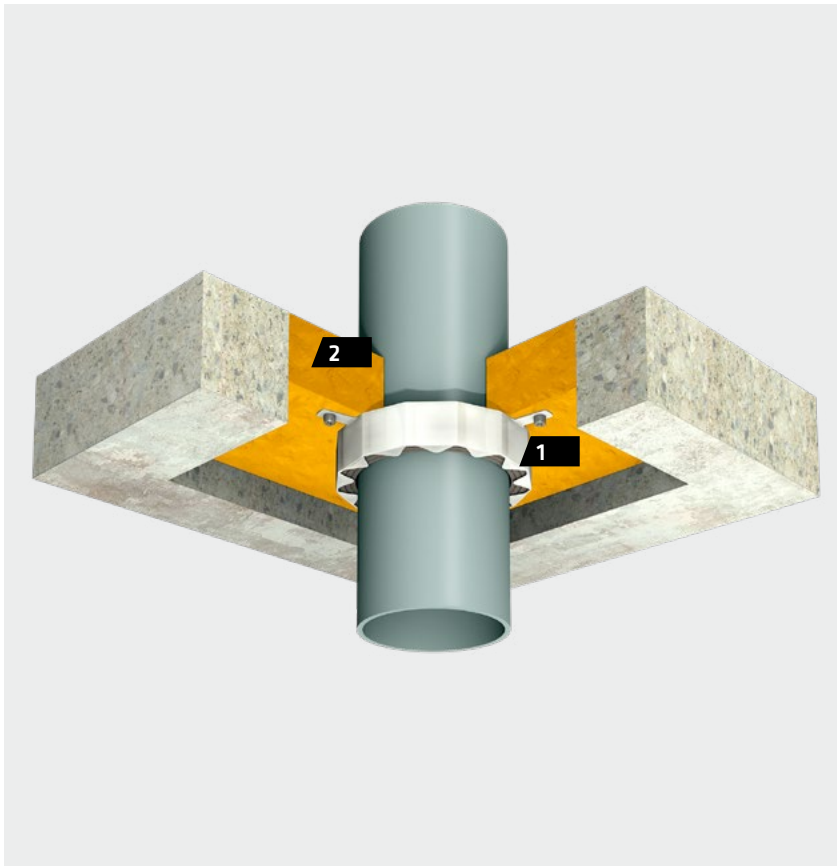

PRODUCTS, MATERIALS

1. SikaSeal®-627 Fire Collar
2. Sikacrete®-630 Fire

CLASSIFICATION

EI 120 U/C for all pipes, see diagram below

DETAILS

- Floor: Thickness ≥ 150 mm, aerated concrete, concrete or brickwork, density ≥ 670 kg/m³
- Pipe details see diagram below
- Sikacrete®-630 Fire: ≥ 100 mm thick, flush on upper side of the floor
- SikaSeal®-627 Fire Collar on the lower side of the floor
- Aperture size $\leq 700 \times 1,400$ mm
- Distance between collars ≥ 0 mm
- Distance between aperture edge and collar ≥ 50 mm
- Distance between floor and pipe support ≤ 400 mm (upper side only)

INSTALLATION INSTRUCTIONS

Refer to the relevant Sika method statement(s)

Pipe diameter, collar diameter (mm)	PVC*	PP	PE**
	Pipe wall thickness (mm)		
32	1.8	2.9	2.9
40	1.8	2.9	2.9
50	1.8	2.9	2.9
55	2.3 - 3.0	2.9 - 4.4	2.9 - 4.4
63	2.3 - 3.0	2.9 - 4.4	2.9 - 4.4
75	3.1 - 4.8	2.8 - 6.7	2.8 - 6.7
82	3.1 - 4.8	2.8 - 6.7	2.8 - 6.7
90	4.2 - 7.4	2.7 - 10.0	2.7 - 10.0
100	4.2 - 7.4	2.7 - 10.0	2.7 - 10.0
110	4.2 - 7.4	2.7 - 10.0	2.7 - 10.0
125	6	3.1	3.1
140	6.1 - 7.5	3.5 - 8.0	3.9 - 5.8
160	6.2 - 9.5	4.0 - 14.6	4.9 - 9.5

* PVC-U, PVC-C

** PE HD, ABS, SAN + PVC

See chapter "Pipe and insulation material"

Layout: 627.2/627.B

PLASTIC PIPES IN RIGID FLOORS, NON-LOAD-BEARING

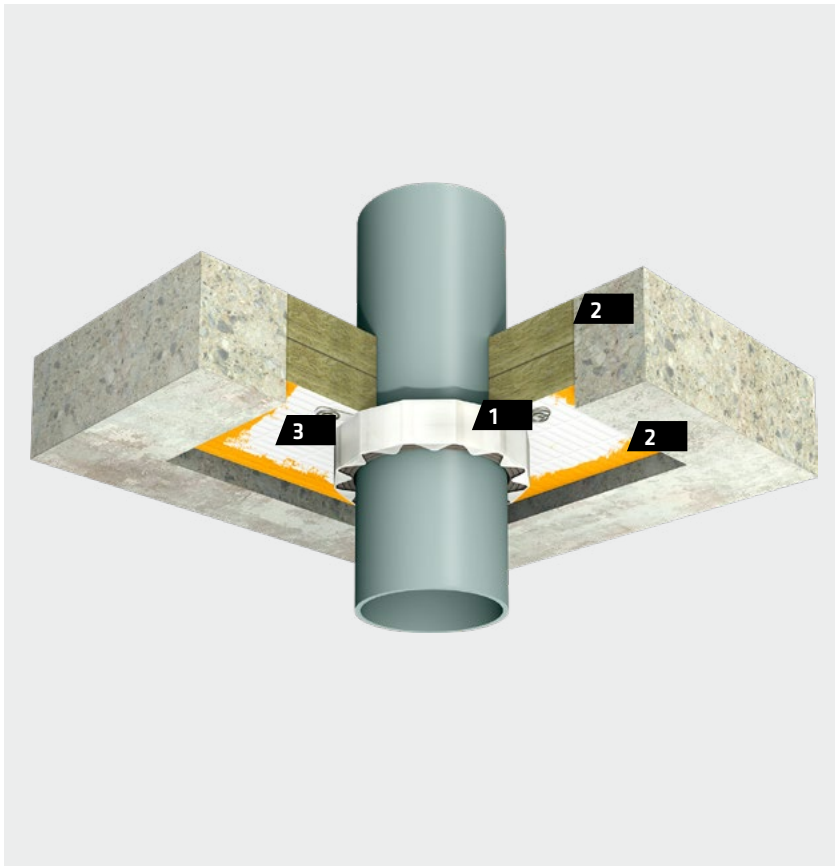

PRODUCTS, MATERIALS

1. SikaSeal®-627 Fire Collar
2. Sikacryl®-621 Fire
3. SikaSeal®-626 Fire Board

CLASSIFICATION

EI 120 U/C for all pipes, see diagram below

DETAILS

- Floor: Thickness ≥ 150 mm, aerated concrete, concrete or brickwork, density ≥ 670 kg/m³
- Pipe details see diagram below
- 2 layers of SikaSeal®-626 Fire Board internal-fit, flush on the upper side of the floor
- Sikacryl®-621 Fire between abutting materials
- SikaSeal®-627 Fire Collar on the lower side of the floor
- Aperture size $\leq 350 \times 1,000$ mm
- Distance between collars ≥ 75 mm
- Distance between aperture edge and collar ≥ 60 mm
- Distance between floor and pipe support ≤ 400 mm (upper side only)

INSTALLATION INSTRUCTIONS

Refer to the relevant Sika method statement(s)

Pipe diameter, collar diameter (mm)	PVC*	PP	PE**
	Pipe wall thickness (mm)		
32	1.8	2.9	2.9
40	1.8	2.9	2.9
50	1.8	2.9	2.9
55	2.3 - 3.0	2.9 - 4.4	2.9 - 4.4
63	2.3 - 3.0	2.9 - 4.4	2.9 - 4.4
75	3.1 - 4.8	2.8 - 6.7	2.8 - 6.7
82	3.1 - 4.8	2.8 - 6.7	2.8 - 6.7
90	4.2 - 7.4	2.7 - 10.0	2.7 - 10.0
100	4.2 - 7.4	2.7 - 10.0	2.7 - 10.0
110	4.2 - 7.4	2.7 - 10.0	2.7 - 10.0
125	6	3.1	3.1
140	6.1 - 7.5	3.5 - 8.0	3.9 - 5.8
160	6.2 - 9.5	4.0 - 14.6	4.9 - 9.5

* PVC-U, PVC-C

** PE HD, ABS, SAN + PVC

See chapter "Pipe and insulation material"

Layout: 627.3/627.C

PLASTIC PIPES IN RIGID FLOORS, NON-LOAD-BEARING

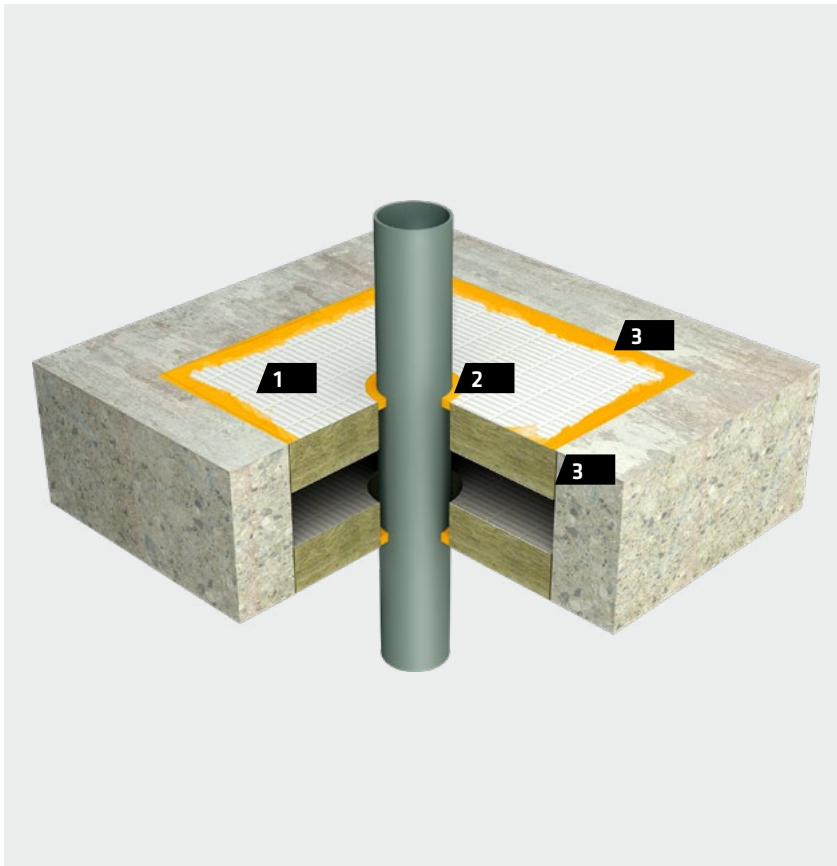

PRODUCTS, MATERIALS

1. SikaSeal®-626 Fire Board
2. SikaSeal®-623 Fire
3. Sikacryl®-621 Fire

CLASSIFICATION

EI 60 U/C

DETAILS

- Floor: Thickness ≥ 150 mm, aerated concrete, concrete or brickwork, density ≥ 670 kg/m³
- SikaSeal®-626 Fire Board internal fit, installed flush on the upper side of the floor or centred in the middle of it
- Pipe details see diagram below
- 20 mm annular space around pipes sealed with SikaSeal®-623 Fire, ≥ 25 mm deep on both sides
- Sikacryl®-621 Fire between board and concrete
- Aperture size $\leq 700 \times 1,600$ mm
- Distance between pipes (sealant) ≥ 50 mm
- Distance between aperture edge and pipes (sealant) ≥ 50 mm
- Distance between floor and pipe support ≤ 400 mm (upper side only)

INSTALLATION INSTRUCTIONS

Refer to the relevant Sika method statement(s)

Pipe diameter / pipe wall thickness diagram

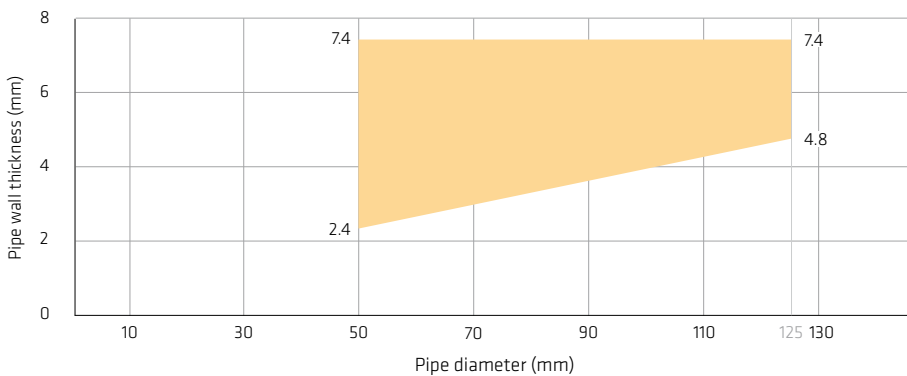

PVC

MLC PIPES IN RIGID FLOORS, NON-LOAD-BEARING

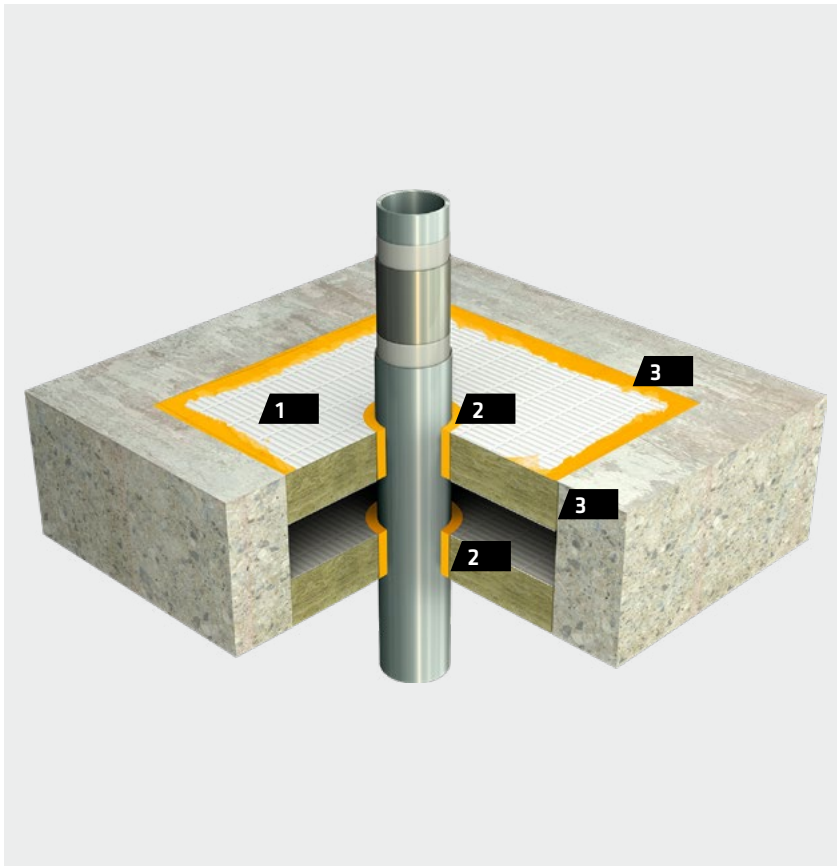

PRODUCTS, MATERIALS

1. SikaSeal®-626 Fire Board
2. SikaSeal®-623 Fire
3. Sikacryl®-621 Fire

CLASSIFICATION

EI 60 U/C

DETAILS

- Floor: Thickness ≥ 150 mm, aerated concrete, concrete or brickwork, density ≥ 670 kg/m³
- 2 layers of SikaSeal®-626 Fire Board internal-fit, flush on the upper side of the floor or in the middle of the floor
- Pipe details see diagram below
- 20 mm annular space around pipes sealed with SikaSeal®-623 Fire, ≥ 25 mm deep on both sides
- Sikacryl®-621 Fire between board and concrete
- Aperture size $\leq 700 \times 1,600$ mm
- Distance between pipes (sealant) ≥ 50 mm
- Distance between aperture edge and pipes (sealant) ≥ 50 mm
- Distance between floor and pipe support ≤ 400 mm (upper side only)

INSTALLATION INSTRUCTIONS

Refer to the relevant Sika method statement(s)

Penetration specification	Diameter (mm)	Pipewall thickness (mm)
Uponore MLC* Pipe	40	4
Uponore MLC* Pipe	50	4.5
Uponore MLC* Pipe	63	6
Uponore MLC* Pipe	75	7.5
Uponore MLC* Pipe	90	8.5
Uponore MLC* Pipe	110	10

*Multi Layer Composite

Layout: 626.19/626.0

CABLES, CABLE TRAYS AND CONDUITS IN FLOORS, LARGE APERTURES

Short description	Products	Code	Page
Cable trays in rigid floors, non-load-bearing Internal fit board installation	SikaSeal®-626 Fire Board SikaSeal®-623 Fire Sikacryl®-621 Fire Sikacryl®-625 Fire	623.7	87
Cables, cable trays and conduits in rigid floors, non-load-bearing Internal fit board installation	SikaSeal®-626 Fire Board Sikacryl®-621 Fire Insulation material	626.17	88
Cables, cable trays and conduits in rigid floors, non-load-bearing	Sikacrete®-630 Fire Insulation material	630.1	89

CABLE TRAYS IN RIGID FLOORS, NON-LOAD-BEARING

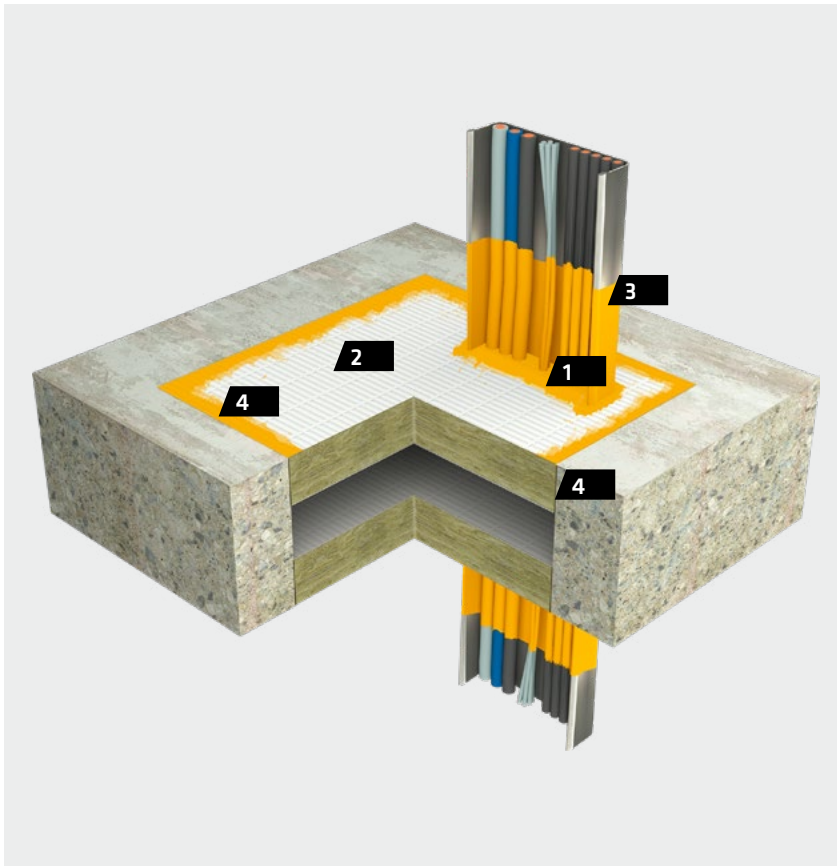

PRODUCTS, MATERIALS

1. SikaSeal®-623 Fire
2. SikaSeal®-626 Fire Board
3. Sikacryl®-625 Fire
4. Sikacryl®-621 Fire

CLASSIFICATION

EI 60

DETAILS

- Floor: Thickness ≥ 150 mm, aerated concrete, concrete or brickwork, density ≥ 670 kg/m³
- 2 layers of SikaSeal®-626 Fire Board internal-fit, flush on both sides of the floor or in the middle of the floor
- Cables, cable tray details see table below
- Coating: Cables and cable trays coated with Sikacryl®-625 Fire on both sides of the floor. Length ≥ 300 mm, DFT (dry film thickness) ≥ 2 mm
- 20 mm space on top of cables sealed with SikaSeal®-623 Fire, 25 mm deep on both sides
- Sikacryl®-621 Fire between abutting materials
- Aperture size $\leq 750 \times 1,100$ mm
- Distance between cable trays ≥ 100 mm
- Distance between aperture edge and cable trays ≥ 50 mm
- Distance between floor and cable tray support ≤ 400 mm (upper side only)

Penetration specification

Cable trays and ladders (perforated and unperforated, width ≤ 500 mm) loaded with the following cables

Electrical cables, diameter ≤ 21 mm

"C1 cable" acc. EN 1366-3

"C2 cable" acc. EN 1366-3

"C3 cable" acc. EN 1366-3

INSTALLATION INSTRUCTIONS

Refer to the relevant Sika method statement(s)

CABLES, CABLE TRAYS AND CONDUITS IN RIGID FLOORS, NON-LOAD-BEARING

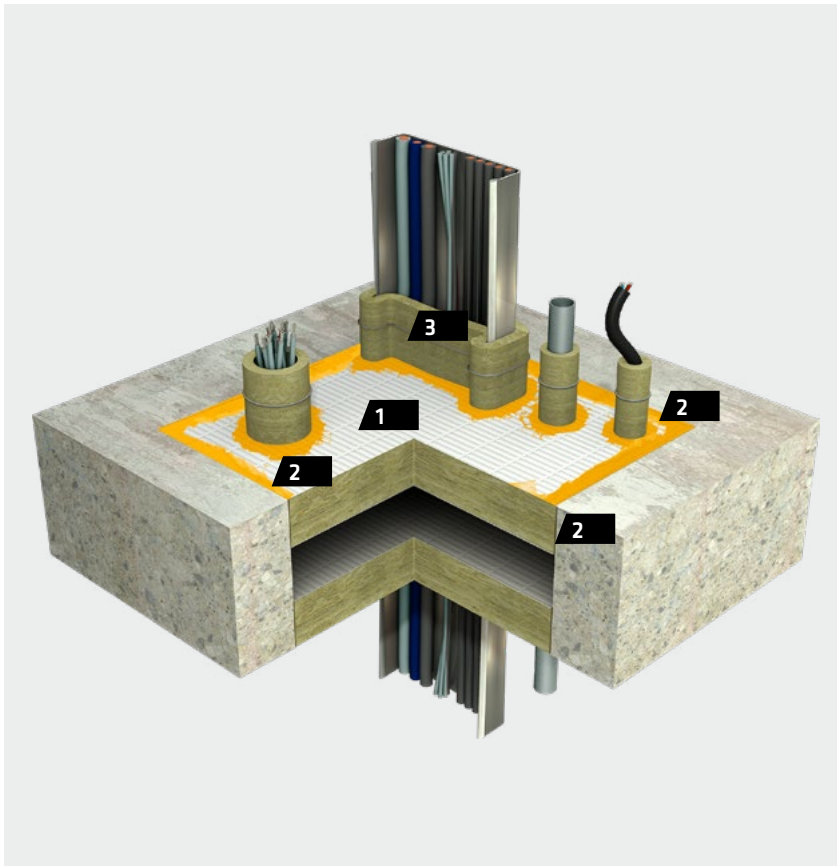

PRODUCTS, MATERIALS

1. SikaSeal®-626 Fire Board
2. Sikacryl®-621 Fire
3. Insulation material

CLASSIFICATION

EI 60

DETAILS

- Floor: Thickness ≥ 150 mm, aerated concrete, concrete or brickwork, density ≥ 670 kg/m³
- 2 layers of SikaSeal®-626 Fire Board internal-fit, flush on the upper side of the floor or in the middle of the floor
- Cables/conduits details see table below
- Insulation: Stone wool or ceramic wool, density ≥ 45 kg/m³, thickness ≥ 40 mm, length ≥ 300 mm, upper side of the floor, LI (local interrupted)
- Sikacryl®-621 Fire between abutting materials
- Aperture size $\leq 700 \times 1,600$ mm
- Distance between cables/cable trays/conduits (insulation) ≥ 50 mm
- Distance between aperture edge and cables/cable trays/conduits (insulation) ≥ 50 mm
- Distance between floor and cable, cable tray support ≤ 400 mm (upper side only)

Penetration specification

Electrical cables, diameter ≤ 80 mm

Cable trays and ladders (perforated and unperforated, width ≤ 500 mm) loaded with the following cables

Cable bunches, diameter ≤ 100 mm, diameter of individual cables ≤ 21 mm

Unsheathed electrical cables, diameter ≤ 24 mm

Steel and copper conduits, diameter ≤ 16 mm

Plastic conduits, diameter ≤ 16 mm

INSTALLATION INSTRUCTIONS

Refer to the relevant Sika method statement(s)

Layout: 626.17/626.M

CABLES, CABLE TRAYS AND CONDUITS IN RIGID FLOORS, NON-LOAD-BEARING

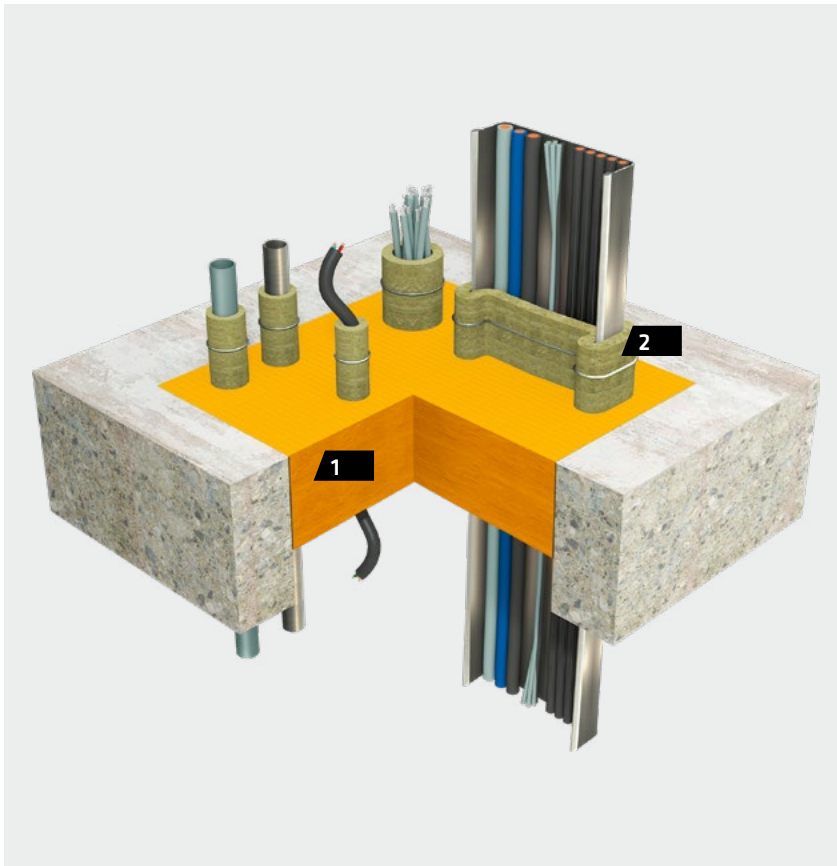

PRODUCTS, MATERIALS

1. Sikacrete®-630 Fire
2. Insulation material

CLASSIFICATION

See table below

DETAILS

- Floor: Thickness ≥ 150 mm, aerated concrete, concrete or brickwork, density ≥ 670 kg/m³
- Cables, cable tray details see table below
- Insulation: Stone wool or ceramic wool, density ≥ 45 kg/m³, thickness ≥ 40 mm, length ≥ 400 mm on the upper side of the floor
- Sikacrete®-630 Fire: ≥ 100 mm thick, flush on the upper side of the floor
- Aperture size $\leq 1,800 \times 1,800$ mm
- Distance between cable, cable trays ≥ 100 mm
- Distance between aperture edge and cable trays ≥ 100 mm
- Distance between floor and cables, cable tray support ≤ 400 mm (upper side only)

INSTALLATION INSTRUCTIONS

Refer to the relevant Sika method statement(s)

Penetration specification	Classification
Electrical cables, diameter ≤ 80 mm	EI 60
Cable trays and ladders (perforated and unperforated, width ≤ 500 mm) loaded with the following cables	
Cable bunches, diameter ≤ 100 mm, diameter of individual cables ≤ 21 mm	
Unsheathed electrical cables, diameter ≤ 24 mm	
PVC conduits, diameter ≤ 16 mm	
Steel conduits, diameter ≤ 16 mm	

INSULATED METAL PIPES IN FLOORS, SMALL APERTURES

Short description	Products	Code	Page
Insulated steel and copper pipes in rigid floors	SikaSeal®-623 Fire Backing material	623.5	91

INSULATED METAL PIPES IN RIGID FLOORS



PRODUCTS, MATERIALS

1. SikaSeal®-623 Fire
2. Backing material

CLASSIFICATION

See table below

DETAILS

- Floor: Thickness ≥ 150 mm, aerated concrete, concrete or brickwork, density ≥ 670 kg/m³
- Pipes: Steel and copper or metals with higher melting point and/or lower thermal conductivity, details see table below
- Pipe insulation: Armaflex AF foam insulation, CS (continuous sustained)
- Core drilled holes, 20 mm annular space around pipes sealed with SikaSeal®-623 Fire, ≥ 25 mm deep on the upper side only
- Backing: Stone wool or ceramic wool, density ≥ 45 kg/m³, depth ≥ 100 mm
- Distance between pipes (sealant) ≥ 100 mm
- Distance between floor and pipe support ≤ 250 mm (upper side only)

INSTALLATION INSTRUCTIONS

Refer to the relevant Sika method statement(s)

Pipe diameter (mm)	Pipe wall thickness (mm)	Pipe insulation thickness (mm)	Classification
41 - 159	2.5 - 14.2	13 - 32	EI 20 U/C
41	1.4 - 14.2	13	EI 60, E 240 U/C

PLASTIC AND MLC PIPES IN FLOORS, SMALL APERTURES

Short description	Products	Code	Page
Plastic pipes in rigid floors	SikaSeal®-627 Fire Collar Sikacryl®-621 Fire	627.1	93
Plastic pipes in rigid floors	Sikacryl®-623 Fire Backing material	623.6	94
Plastic pipes in rigid floors	SikaSeal®-628 Fire Wrap Sikacryl®-621 Fire	628.1	95
Plastic pipes in rigid floors	SikaSeal®-629 Fire Wrap Sikacryl®-621 Fire	629.1	96

PLASTIC PIPES IN RIGID FLOORS, LOAD-BEARING

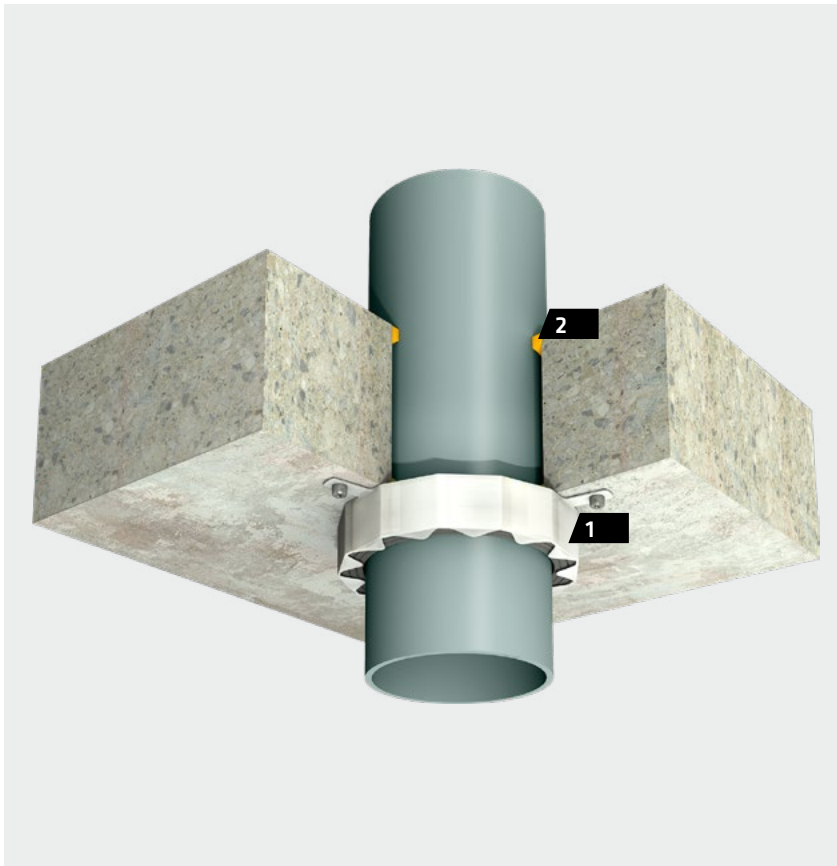

PRODUCTS, MATERIALS

1. SikaSeal®-627 Fire Collar
2. Sikacryl®-621 Fire

CLASSIFICATION

EI 240 U/C for all pipes, see diagram below

DETAILS

- Floor: Thickness ≥ 150 mm, aerated concrete, concrete or brickwork, density ≥ 670 kg/m³
- Pipe details see diagram below
- Core drilled holes, ≤ 10 mm annular space around pipes
- Sikacryl®-621 Fire ≥ 12.5 mm deep, double seal
- SikaSeal®-627 Fire Collar on the lower side of the floor
- Distance between collars ≥ 100 mm
- Distance between floor and pipe support ≤ 400 mm (upper side only)

INSTALLATION INSTRUCTIONS

Refer to the relevant Sika method statement(s)

Pipe diameter, collar diameter (mm)	PVC*	PP	PE**
	Pipe wall thickness (mm)		
32	1.8	2.9	2.9
40	1.8	2.9	2.9
50	1.8	2.9	2.9
55	2.3 - 3.0	2.9 - 4.4	2.9 - 4.4
63	2.3 - 3.0	2.9 - 4.4	2.9 - 4.4
75	3.1 - 4.8	2.8 - 6.7	2.8 - 6.7
82	3.1 - 4.8	2.8 - 6.7	2.8 - 6.7
90	4.2 - 7.4	2.7 - 10.0	2.7 - 10.0
100	4.2 - 7.4	2.7 - 10.0	2.7 - 10.0
110	4.2 - 7.4	2.7 - 10.0	2.7 - 10.0
125	6	3.1	3.1
140	6.1 - 7.5	3.5 - 8.0	3.9 - 5.8
160	6.2 - 9.5	4.0 - 14.6	4.9 - 9.5

* PVC-U, PVC-C

** PE HD, ABS, SAN + PVC

See chapter "Pipe and insulation material"

Layout: 627.1/627.A

PLASTIC PIPES IN RIGID FLOORS

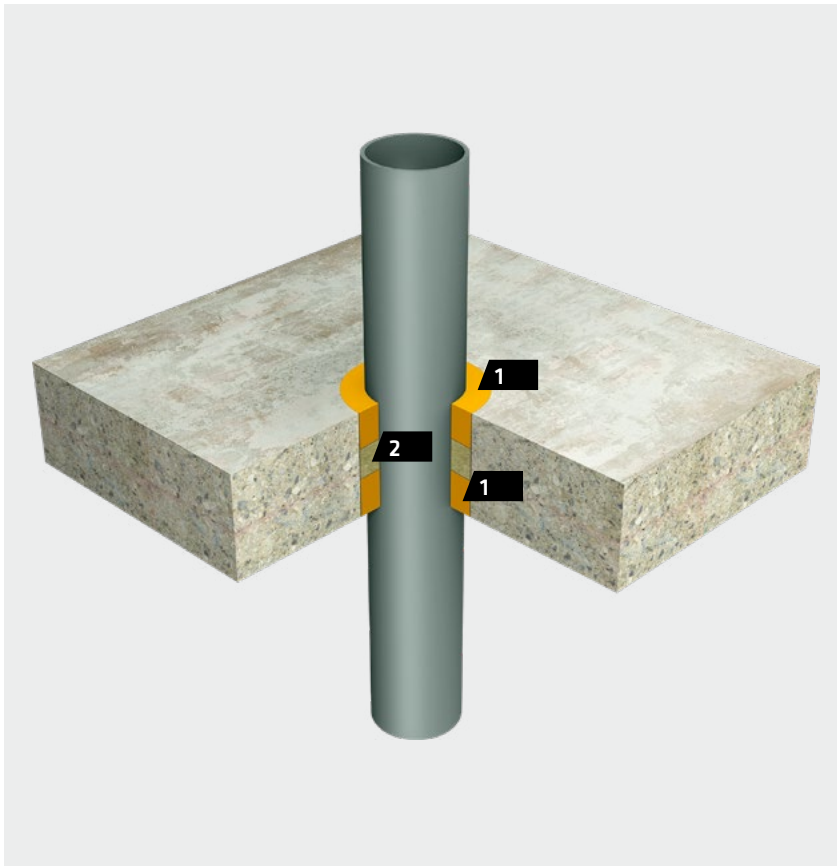

PRODUCTS, MATERIALS

1. SikaSeal®-623 Fire
2. Backing material

CLASSIFICATION

PVC: **EI 30 E 90 U/C**

PE: **EI 60 U/C**

PP: **EI 30 U/C**

See diagram below

DETAILS

- Floor: Thickness ≥ 150 mm, aerated concrete, concrete or brickwork, density ≥ 670 kg/m³
- Pipes details see diagram below
- Core drilled holes, 20 mm annular space around pipes sealed with SikaSeal®-623 Fire, ≥ 25 mm deep on the both sides of the floor.
- Backing: Stone wool or ceramic wool, density ≥ 45 kg/m³, depth ≥ 100 mm
- Distance between pipes (sealant) ≥ 100 mm
- Distance between floor and pipe support ≤ 250 mm (upper side only)

INSTALLATION INSTRUCTIONS

Refer to the relevant Sika method statement(s)

Pipe diameter / pipe wall thickness diagram

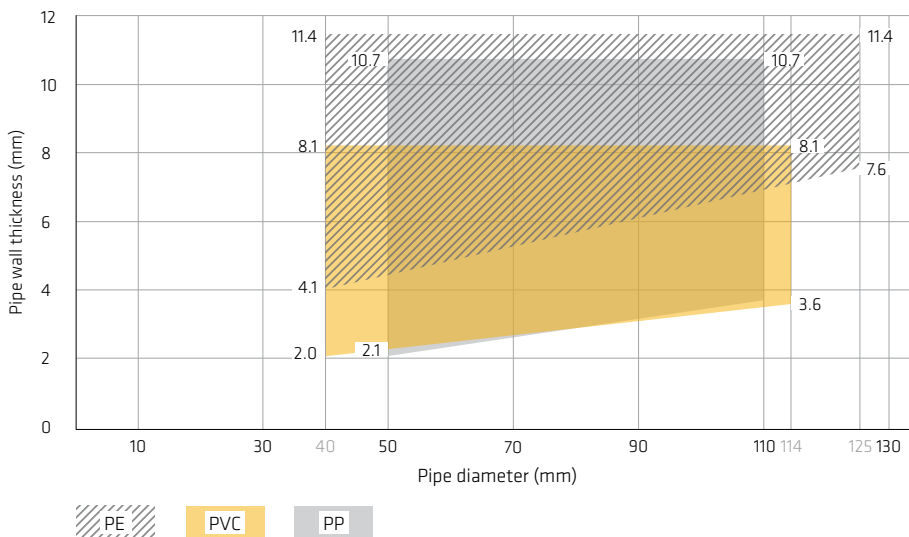

Layout: 623.6/623.E

PLASTIC PIPES IN RIGID FLOORS

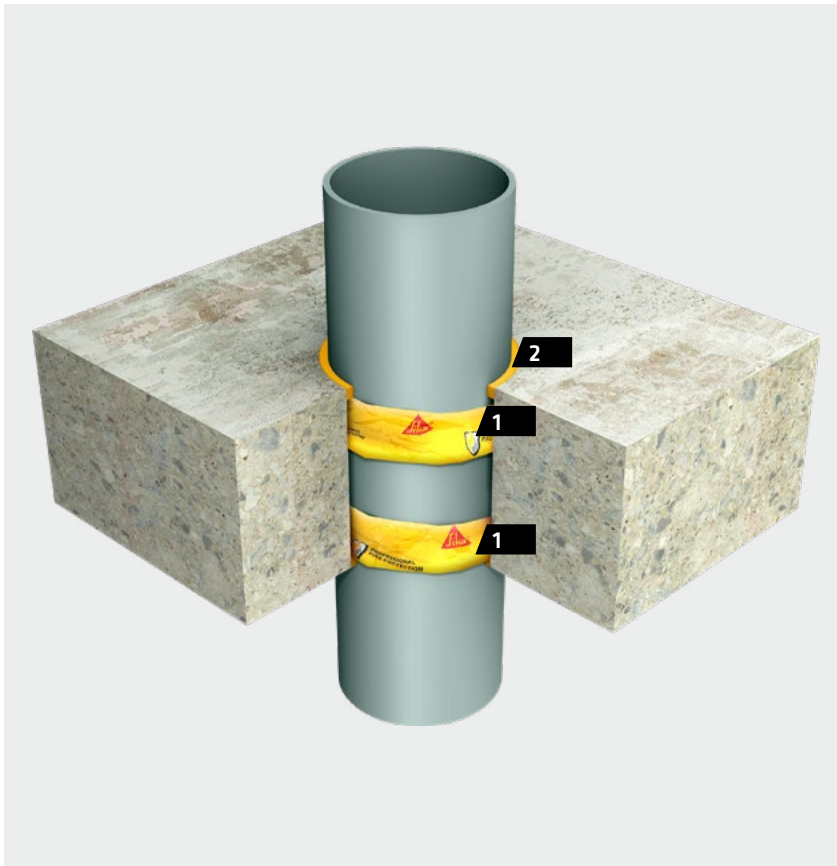

PRODUCTS, MATERIALS

1. SikaSeal®-628 Fire Wrap
(SikaSeal®-629 Fire Wrap alternatively)
2. Sikacryl®-621 Fire

CLASSIFICATION

PVC: EI 60 U/C

PP, PE: EI 120 U/C

Details see diagram below

DETAILS

- Floor: Thickness ≥ 150 mm, aerated concrete, concrete or brickwork, density ≥ 670 kg/m³
- Pipe details see diagram below
- Core drilled holes, annular space around pipes see table below
- SikaSeal®-628 Fire Wrap according to pipe diameter on both sides; alternatively SikaSeal®-629 Fire Wrap according to table below on both sides
- Sikacryl®-621 Fire 5 mm deep on both sides
- Distance between pipes (wrap) ≥ 100 mm
- Distance between floor and pipe support ≤ 400 mm (upper side only)

INSTALLATION INSTRUCTIONS

Refer to the relevant Sika method statement(s)

Pipe diameter / pipe wall thickness diagram

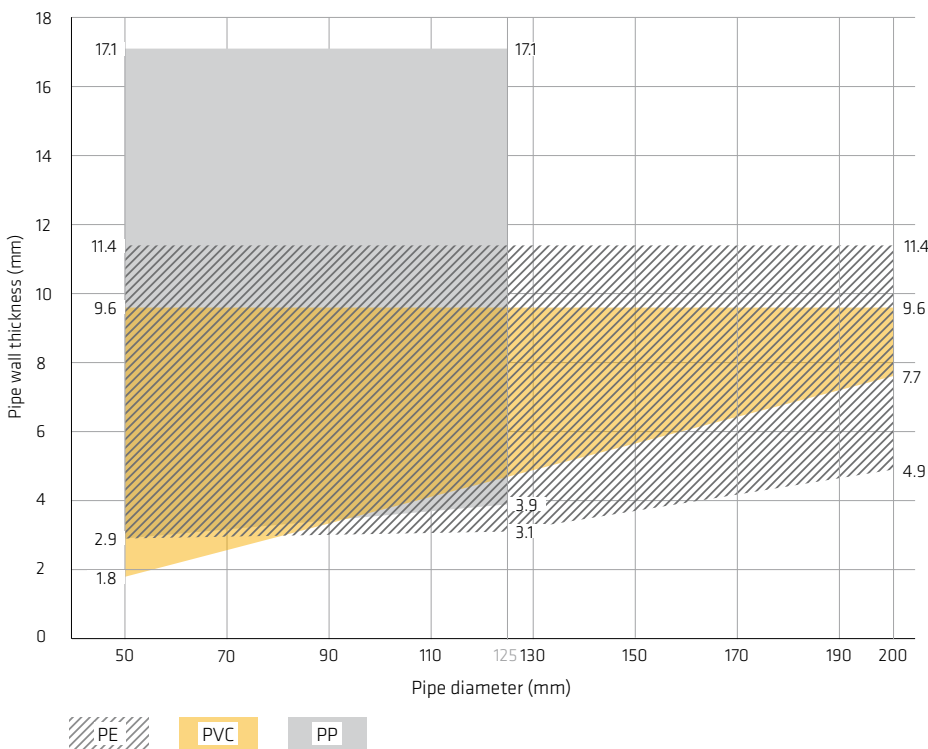

Pipe diameter (mm)	Annular space (mm)	Numbers of layers of SikaSeal®-629 Fire Wrap
32 - 50	4	1
50 - 82	6	2
82 - 115	8	3
115 - 160	10	4
160 - 200	12	5
200 - 250	14	6

Layout: 628.1/628.A

PLASTIC PIPES IN RIGID FLOORS

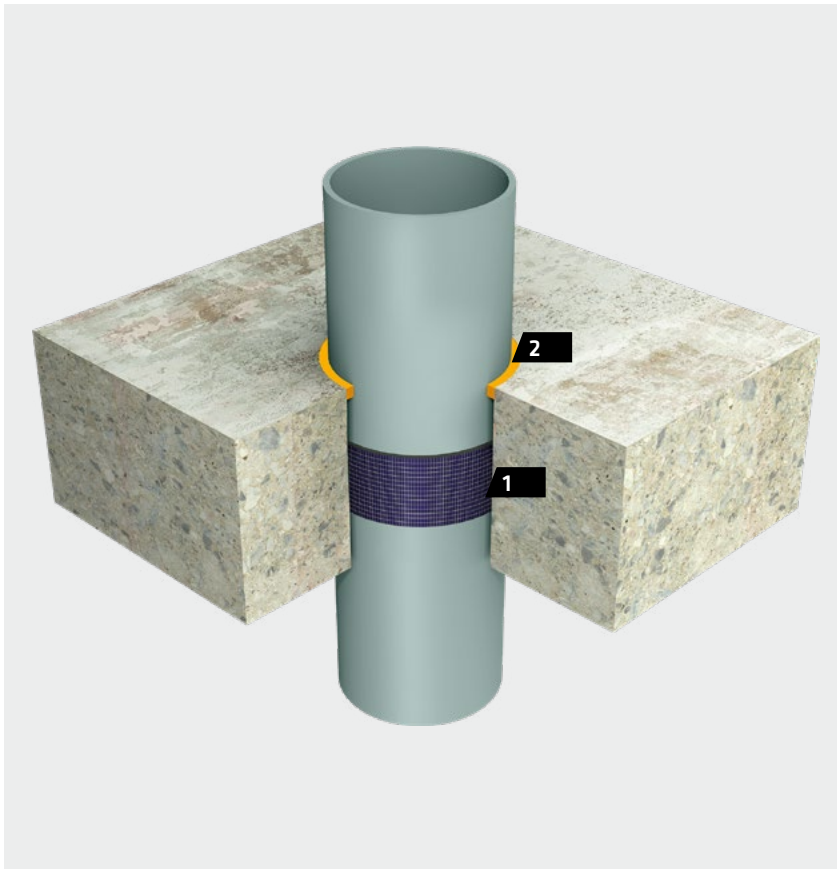

PRODUCTS, MATERIALS

1. SikaSeal®-629 Fire Wrap
2. Sikacryl®-621 Fire

CLASSIFICATION

PVC: **EI 60 U/C**

PE: **EI 240 U/C**

PP: **EI 120 U/C**

Details see diagram below

DETAILS

- Floor: Thickness ≥ 150 mm, aerated concrete, concrete or brickwork, density ≥ 670 kg/m³
- Pipe details see diagram below
- Core drilled holes, annular space around pipes see table below
- SikaSeal®-629 Fire Wrap according to table below in the middle of the floor or lower
- Sikacryl®-621 Fire 10 mm deep on the upper side using a PE backer rod for large pipe diameters
- Distance between pipes (wrap) ≥ 100 mm
- Distance between floor and pipe support ≤ 400 mm (upper side only)

INSTALLATION INSTRUCTIONS

Refer to the relevant Sika method statement(s)

Pipe diameter / pipe wall thickness diagram

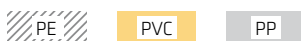
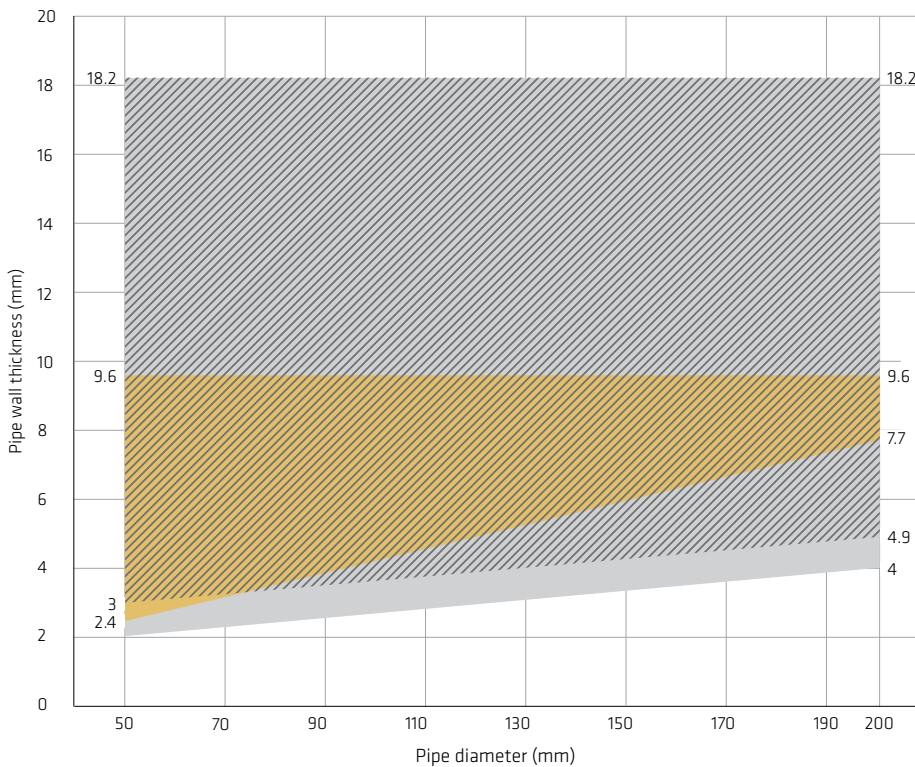

Layout: 629.1/629.A

Pipe diameter (mm)	Annular space (mm)	Numbers of layers of SikaSeal®-629 Fire Wrap
32 - 50	6	2
50 - 82	10	4
82 - 115	14	6
115 - 160	18	8
160 - 200	22	10
200 - 250	26	12

SIKA FULL RANGE SOLUTIONS FOR CONSTRUCTION:



LIQUID APPLIED ROOFING



SINGLE PLY ROOFING

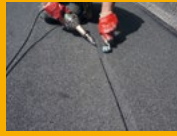

BITUMINOUS ROOFING



CONCRETE



CONCRETE REPAIR



STRUCTURAL STRENGTHENING



BUILDING FINISHING



WATERPROOFING



JOINT SEALING



FACADE STRUCTURAL ADHESIVES



FLOORING



INDUSTRY



DISTRIBUTION



BUILDING TRUST

FOR FURTHER INFORMATION:

Contact John Gardner Mobile: 07881 379400
or email: gardner.john@uk.sika.com

WHO WE ARE

Sika Limited and Sika Ireland Limited are part of the global Sika Group, specialising in the manufacture and supply of chemical based products. Sika has a leading position in the development and production of systems and products for bonding, sealing, damping, reinforcing, and protecting in the building sector and the motor vehicle industry. Sika has subsidiaries in 101 countries around the world and manufactures in over 300 factories. With more than 25,000 employees Sika generates annual sales of CHF 8.1 billion (£6.6 bn). We are also committed to providing quality, service, safety and environmental care.

In the UK and Ireland, we provide market-leading solutions for concrete, waterproofing, roofing, flooring, refurbishment, sealing & bonding, and industry, and have manufacturing sites in Welwyn Garden City, Preston, Leeds, Wishaw and Dublin with more than 1000 employees and a turnover of more than £270 million.

The information, and, in particular, the recommendations relating to the application and end use of Sika® products, are given in good faith based on Sika's current knowledge and experience of the products when properly stored, handled and applied under normal conditions. In practice, the differences in materials, substrates and actual site conditions are such that no warranty in respect of merchantability or of fitness for a particular purpose, nor any liability arising out of any legal relationship whatsoever, can be inferred either from this information, or from any written recommendations, or from any other advice offered. The proprietary rights of third parties must be observed. Please refer to our homepage www.sika.co.uk for our current standard terms & conditions applicable to all orders. Users should always refer to the most recent issue of the Product Data Sheet for the product concerned, copies of which will be supplied on request.



SIKA LIMITED

Head Office
Watchmead
Welwyn Garden City
Hertfordshire, AL7 1BQ
United Kingdom

Contact

Phone +44 1 707 394444
Fax +44 1 707 329129
E-Mail enquiries@uk.sika.com
www.sika.co.uk
@SikaLimited

BUILDING TRUST

