



METHOD STATEMENT

3D Concrete Printing using 1-component Sikacrete[®] 3D

OCTOBER 2023 / RELEASE 1 / SIKA SERVICES AG

FOR INFORMATION

BUILDING TRUST



CONTENTS

1	INTRODUCTION	3
2	SCOPE	3
3	DEFINITIONS	4
4	SYSTEM DESCRIPTION	5
4.1	REFERENCES.....	6
4.2	LIMITATIONS.....	6
5	SIKA 3DCP PRODUCTS	7
6	HEALTH, SAFETY AND ENVIRONMENT	7
6.1	RISK ASSESSMENT	7
6.2	PERSONAL PROTECTIVE EQUIPMENT	7
6.3	FIRST AID.....	8
6.4	ENVIRONMENT	8
7	STORAGE	8
8	MATERIALS, TOOLS, AND EQUIPMENT	9
8.1	MATERIALS.....	9
8.2	HANDLING TOOLS	9
8.3	QUALITY CONTROL TOOLS.....	9
8.4	MAIN EQUIPMENT	10
8.5	SUITABLE TYPES OF MIXING EQUIPMENT	10
8.5.1	Forced action pan mixers	10
8.5.2	Continuous mixers.....	11
8.6	UNSUITABLE MIXING EQUIPMENT.....	11
8.7	SUITABLE TYPES OF PUMPS	12
8.7.1	Eccentric screw pump	12
8.8	COMBINED MIXER PUMP EQUIPMENT	12
8.9	UNSUITABLE MIXER AND PUMPS	13
8.9.1	Combined forced action mixer with pump	13
8.9.2	Continuous mixer pump.....	13
8.10	CLEANING TOOLS	14
8.11	PRINTING ANCILLARIES	15
8.12	ADDITIONAL TOOLS	15
9	PRINTING PREPARATION	15
9.1	BASIC PROCEDURE.....	15
9.2	EVALUATE WORKING CONDITIONS	16
9.3	PREPARING THE EQUIPMENT	17
9.3.1	Forced action pan mixer.....	18
9.3.2	Continuous mixers.....	19
9.3.3	Pumping equipment.....	19
9.3.4	Rotor-stator.....	19
9.3.5	Hose pipe.....	21
9.3.6	Nozzles and print heads	21
9.4	PREPARE THE MATERIAL	21
9.5	LUBRICATE THE HOSE PIPE	22
9.6	PROGRAM THE PRINTED OBJECT.....	23
9.7	FIND THE RIGHT MIXING WORKABILITY	23
9.7.1	Forced action pan mixers	24
9.7.2	Continuous mixers.....	26

9.8	START WITH A TEST PRINT	26
10	PRINTING	27
10.1	START THE PRINTING (APPLICATION)	28
10.1.1	Printing platform	28
10.1.2	Print stability	28
10.1.3	Forced action pan mixers	28
10.1.4	Continuous mixers	29
10.1.5	Pumps	29
10.1.6	Pot life	30
10.1.7	Interlayer time	30
10.1.8	Breaks	30
10.2	OPTIMISING THE PRINTING QUALITY	30
10.3	CURE THE PRINTED OBJECTS	31
10.4	MOVING THE PRINTED OBJECTS	32
10.5	FINAL USE OF THE PRINTED OBJECT	33
10.5.1	Collecting data	33
11	INSPECTION, SAMPLING AND QUALITY CONTROL	35
12	CLEANING	36
13	REDUCING STOPPAGES	37
14	RECOMMENDED EQUIPMENT	38
15	MORE SIKA 3DCP SOLUTIONS	39
16	EXAMPLE PRINT REPORT	40
17	LEGAL NOTE	41



1 INTRODUCTION

3D Concrete Printing (3DCP) is a manufacturing process combining mixing, pumping and robotics to print layered lines using a mineral based micro-concrete. The Sikacrete[®]-700 3D series are 1-component Products (also referred to as the “material”) comprising of a dry powder and filler, and selected additives. Sikacrete[®]-700 3D series materials are suitable for use with various mixing and pumping equipment.

Mineral binders, especially cement in mortars and concrete are well known to be sensitive to temperature and humidity fluctuations. This means the fresh mixed 3D material needs to be constantly monitored and adjusted according to the changing conditions.

To have a repeatable constant and successful printed object every time in an ideal world.

- a) There would be no variability in raw materials
- b) the ambient temperature and humidity would always be the same
- c) the material and water temperature would always be the same
- d) the equipment setup and preparation would always be the same
- e) the mixed material temperature would always be the same
- f) the material consistency would always be the same
- g) the equipment and material works perfectly together
- h) there would be no variations
- i) there would be no challenges

But unfortunately, this is seldom possible however some procedures can be standardised, data can be collected for future reference and by implementing quality control measures the printing efficiency and productivity can be improved.

Even though this method statement discusses the common mixing methods for mineral binder materials, the general industry direction for medium to large 3DCP equipment is heading towards the combined continuous mixers and pumps for better and consistent print quality.

3DCP is a new manufacturing process and this method statement does not prohibit personnel experiences, opinion, practices, or results.

2 SCOPE

This method statement describes best demonstrated practices for mixing and pumping 1-component mineral binders, typically containing cement, in a micro-concrete for printing 3D objects using an additive manufacturing or extrusion process. It is offered as a guide to handling Sikacrete[®] 3D products and does not supersede specifications, guidance or information provided by the equipment manufacturer or supplier.

The following subjects are out of scope of this document.

- Drawing, slicing or operational software use.
- Equipment operational use and maintenance.
- Object design.

Sika does not accept any responsibility or liability for the end use of the printed objects.

The Best Demonstrated Practices (BDP) of handling cement based mineral binders still apply for 3DCP.
The best building practices, regulations and legislations for construction still apply for 3DCP objects

3 DEFINITIONS

The following terminology are used in this method statement.

1K	Refers to a 1-component ready to use dry component which requires the addition of water to begin the hydration process
Accelerator	Additive included within the 1-component material to activate the cement sooner, decreasing the setting time, increasing the hardening rate or both.
Additive	Additional material which can be added to the material to enhance the appearance or performance, for example an integral colour component
Big bag	Also called super-sack or BB used to package a larger quantity of material
Continuous Mixer	An equipment that feeds the dry material into a chamber at a constant rate where it is combined with water and mixed for a short time to produce a fresh mixed material. The process can be non-stop or semi-continuous.
Fresh material	Material combined with water, homogeneously mixed which can be pumped to the nozzle or print head.
Gantry printer	A bridge like steel structure having the ability to transverse a print head in a X-Y-Z axis
Hose lubricator	Ingredient that is pushed through the inside of the pipe and other components to aid the flow of fresh material to prevent stoppages.
Interlayer time	The time in minutes or seconds when nozzle or print head completes a one-layer revolution
Material	The Sikacrete® 3D pre-mix of a cement containing dry powder, fillers, and specially selected additives
Mixer	Where the Sikacrete® 3D material and water are combined and mix thoroughly to produce a homogeneously fresh mixed material
Mixed batch	One mix of the Sikacrete® 3D powder and water in a defined quantity. Usually applicable to forced action pan mixers.
Mixer pump	Combined continuous mixer and mortar pump in one equipment
Mortar pump	Usually, an eccentric screw pump (often referred to as worm or schnecken pump) used to convey the fresh mixed material a constant rate through a hose to the print head or nozzle
Nozzle	Round or rectangular vertical pipe where the fresh mixed material is extruded. Usually available in different diameters and is fixed to the robotic arm or gantry at the end of the print head.
Operator	Responsible person(s) for the printing process handling the material and equipment
Pan mixer	Forced action mixer suitable for mixing mortars
Bagged material	Packaging for a smaller quantity of material, usually paper bags.
Pot Life	The time duration in minutes of the material after combining with water when it is suitable for printing, also called the material open time
Print head	A unit mounted to the end of the robotic arm or gantry where the hose is connected and feeds the fresh material to the nozzle, possibly with an option to mix in further additions.
Robotic Printer	A mechanised arm controlled by a computer which has multiple axis movement that pivots from a fixed point to which the print head or nozzle is attached
Silo	Material storage vessel that feeds powder to the mixer
Shelf life	Time in months whereby a material can maintain its performance properties in defined storage conditions
Water	Clean potable water

Abbreviations

PDS	Product Data Sheet contains relevant information about the product
MSDS	Material Safety Data Sheet. Contains information about the safety of a product, storage, transport, and handling
PPE	Personal Protective Equipment such as gloves, safety goggles, safety shoes, masks, and protective clothing.

4 SYSTEM DESCRIPTION

3D Concrete Printing is a complex technology requiring the equipment, the material, and the software to work in harmony.

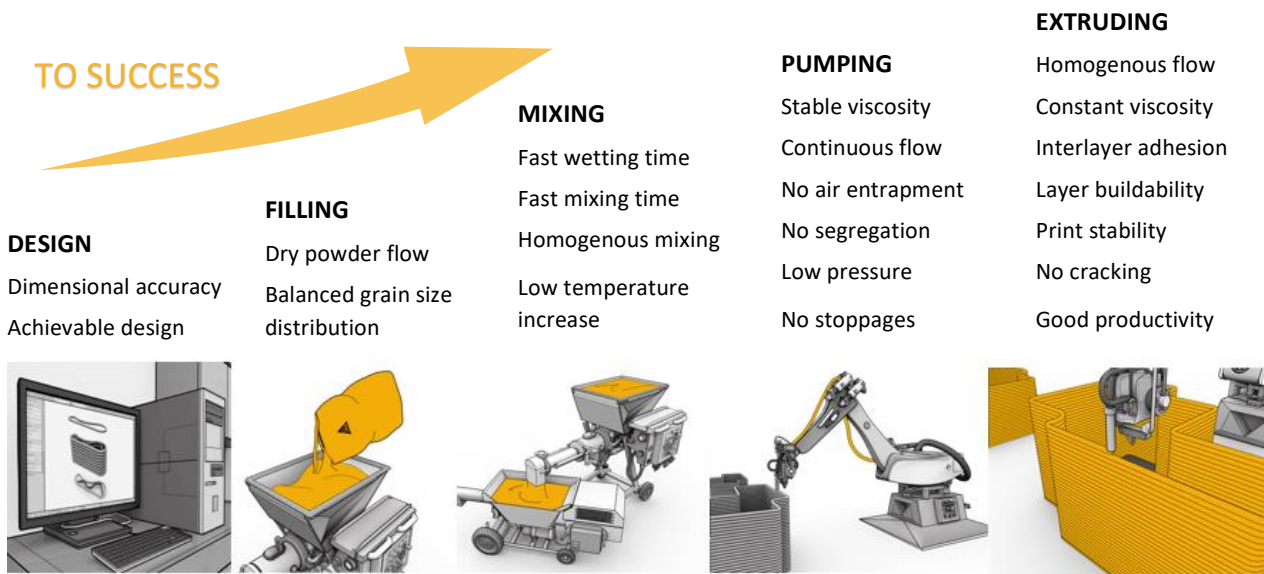

The equipment must ensure a thorough mixing of the Sikacrete® 3D material to produce a consistent homogenous mix which can be easily pumped and transported through a pipe to a print head where the material is extruded through a nozzle.

Through motion of the print head, extruded lines of material are formed on top of each other which must be able to keep their shape once printed so that subsequent fresh lines can be deposited on top of the previous layer. The building up of layers, or stacking, forms the shape of the printed object.

The ambient temperature, material temperature, wind, mixing energy, pumping energy and water content will play a significant role on achieving a constant quality of the printed material.

USES

Digitalised construction techniques are an alternative to traditional cast concrete with formwork and can be used for precision concrete printing of 3D objects on-site or in prefabrication facilities.

- Buildings/building elements
- Civil Engineering elements
- Moulds and forms
- Art, craft, and visual displays
- Interior and exterior use

CHARACTERISTICS

Sikacrete® 3D is a product range offering different characteristics to suit the printing requirements.

- Quality controlled pre-mix
- Fast mixing
- Pumpable
- Buildable workability

ADVANTAGES

- Easy to use 1-component materials that only require mixing with water.
- Pre-tested with the main 3DCP equipment suppliers
- Optimised aggregate grading for lower equipment wear.
- Consistent performance in controlled temperature conditions.
- Adjustable consistencies to compensate for temperature variations.
- Build heights >2m.
- Good interlayer adhesion.
- Maintains shape after extrusion for dimensional accuracy.
- Uniform and consistent appearance.
- Optional high final strengths to support loads.
- Optional accelerated products to improve productivity and for low temperatures.
- Optional products with long open times for extended interlayer times or warm climates

4.1 REFERENCES

The following references relate to test methods

European Standards

EN 196	Methods of testing cement. Determination of strength
EN 480-2	Determination of setting time

North American Standards

ASTM C191 - 19	Standard Test Methods for Time of Setting of Hydraulic Cement by Vicat Needle
ASTM C348 -08	Standard test methods for flexural strength of hydraulic cement mortar
ASTM C1107	Standard test method for compressive strength of hydraulic cement mortar
ASTM C1583	Standard test method for tensile strength of concrete surfaces and the bond strength or tensile strength of concrete repair and overlay materials by direct tension (pull-off method)

4.2 LIMITATIONS

- The Material shall only be applied in accordance with the intended use.
- Local differences in some products may result in some slight performance variations. The most recent and relevant local Product Sheet (PDS) and Material Safety Data Sheet (MSDS) shall apply.
- This method statement is only a guide and shall be adapted to suit local products, Standards, legislations, or other requirements.
- 3DCP is a new manufacturing process and this method statement does not prohibit personnel experiences, opinion, practices, or results.

5 SIKA 3DCP PRODUCTS

The current range of one-component Sikacrete® 3D products.

MATERIAL	DESCRIPTION
Sikacrete®-731 3D	Grey colour with long interlayer time suitable for warm climates with a maximum grain size 1 mm
Sikacrete®-733 3D	Grey colour containing fibres with long interlayer time, lower CO ₂ footprint, and suitable for cool climates with a maximum grain size 3 mm
Sikacrete®-751 3D	Light grey-white colour with accelerated setting suitable for cool climates with a maximum grain size 1 mm
Sikacrete®-752 3D	White colour with slower setting suitable for warm climates with a maximum grain size 2 mm

For technical information refer to the most recent PDS and for packaging sizes refer to your local Sika sales office.

In view there is currently no specific Standard for testing printed 3D concrete, the declared values in the PDS are based on existing Standards for laboratory testing. Actual measured data, from printed elements, may vary due to the nature of printing and stacking layers.

6 HEALTH, SAFETY AND ENVIRONMENT

6.1 RISK ASSESSMENT



The risk to health and safety from manufacturing and construction related issues shall be evaluated by the printing company and adequately communicated to the operators, users, and visitors, in accordance with local regulations, laws, and legislation.

REFER TO THE PRINTING COMPANY'S RISK ASSESSMENT.

6.2 PERSONAL PROTECTIVE EQUIPMENT



Work Safely!

Appropriate eye protection shall be always worn particularly while handling and mixing products. Approved dust masks shall be worn to protect the nose and throat from dust. Safety gloves and protective clothing shall be worn when handling the material and printed objects. Safety shoes shall be worn while working with the materials and equipment.

Always wash hands with suitable soap after handling products and before food consumption.

For further information about the Product refer to the relevant Material Safety Data Sheet

PPE SHALL BE PROVIDED BY THE PRINTING COMPANY IN ACCORDANCE WITH LOCAL REGULATIONS

6.3 FIRST AID



Seek immediate medical attention in the event of excessive dust inhalation, ingestion or eye contact causing irritation. Do not induce vomiting and follow direction by trained medical personnel. Flush eyes with plenty of clean water occasionally lifting upper and lower eyelids. Remove contact lenses immediately. Continue to rinse eye and seek medical attention. Rinse contaminated skin with plenty of water. Remove contaminated clothing, continue to rinse, and seek medical attention.

For further information about the Product refer to the relevant Material Safety Data Sheet

FIRST AID FACILITIES SHALL BE PROVIDED BY THE PRINTING COMPANY IN ACCORDANCE WITH LOCAL REGULATIONS

6.4 ENVIRONMENT



Do not empty surplus material into drains. Dispose responsibly through licensed waste disposal contractor in accordance with local, regional, or national legislation, laws, or authority requirements. Do not allow runoff into soil, waterways, drains or sewers.

For further information about the Product refer to the relevant Material Safety Data Sheet

WASTE MANAGEMENT SHALL BE PROVIDED BY THE PRINTING COMPANY IN ACCORDANCE WITH LOCAL REGULATIONS

7 STORAGE

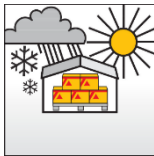

Refer to the relevant Product Data Sheet for minimum and maximum storage temperatures.

Mineral binders, especially cement, are very sensitive to humidity, and it is very important to store the material immediately in a dry internal location.

In general, the material shall be kept in undamaged original sealed packaging, protected from direct sunlight, in relative humidity <75% and stored in dry cool conditions. Do not use material if the date on the packaging has expired. Do not use the material from ripped or damaged packaging, or material that has become contaminated. Report any issues to Sika

Store the material away from water and condensation. Do not locate a cleaning station near any material storage area, a silo or bag feeder.

Do not remove the protective wrapping or open the bags until the material is to be used. Opened big bags shall be tightly sealed after use.

Any moisture or humidity which comes in to contact with cement will start the hydration process causing solid lumps or stones to form in the bag that can block the mixer and cause stoppages.

Visually inspect the big bag after removing the protective wrapping. Pay particular attention to the slings used to lift the big bags to make use there are no damage or tears. Do not use a sling that has been damaged to lift the bag and report any issue to Sika.

If in doubt, contact your local Sika Technical Department for further advice.

8 MATERIALS, TOOLS, AND EQUIPMENT

This section covers the material, general tools, or equipment that may be required for a successful 3D concrete printing but are not limited to these lists. Always consider handling mortars and concrete is messy, hazardous and time consuming. Removal of dried mortar may only be removed by mechanical means.

8.1 MATERIALS

The following are required for handling the materials, but not limited to this list.

Sikacrete® 3D	Sufficient material ⁽¹⁾
Water	Suitable clean potable supply for mixing, pre-wetting hose & cleaning
Sika® Pump Start-1	Hose lubrication
Sika® Antisol	Curing compound ⁽²⁾
Sika® Care range	Equipment maintenance to prevent rust or material build up ⁽³⁾
Cleaning agent	For removing dried or set material on the equipment ⁽³⁾

(1) Refer to your local Sika sales department price list for packaging variations

(2) Some curing compounds may not be compatible with a protection overlay system or may cause staining. Always make a test application before use.

(3) Refer to Equipment Manufacturer's recommendations

8.2 HANDLING TOOLS

The following tools and equipment may be required for handling the materials, but not limited to.

Hand tools	General tool set including metal, wooden and rubber hammers, screw drivers, wrenches, spanners Allen keys, knife, pliers etc
Trowels and floats	For handling fresh material
Plastic spatulas	For handling fresh material
~15 l medium buckets (several)	Material sampling, cleaning, prepare hose lubricant etc.
Paddle mixer	Tool for mixing hose lubricator
Material handling equipment	Pallet lifter, overhead gantry, or forklift for safe lifting

8.3 QUALITY CONTROL TOOLS

The following instruments and equipment may be used to control the material quality, but not limited to.

Workability test for spread flow	Check fresh material workability using spread flow. Typical test method EN 13395 and ASTM C939
Compression and flexure test	Suitable foam or metal forms to prepare specimens. Typical test method according to EN 196-1 and ASTM C1107.
Thermometers	For checking material, ambient temperature, relative humidity, and infrared type for measuring temperature at a safe distance
Scale or balance	Measurable up to 30 kg for material calibration. Minimum resolution: 0.001kg
Microwave	For checking moisture content of fresh material
Timer	To 0.1 seconds

8.4 MAIN EQUIPMENT

The following basic equipment is required for mixing and conveying the material. The robotic arm, gantry structure, computer, and software are not in the scope of this method statement.

Mixing equipment	Suitable for combining the Sikacrete® 3D material with water to produce a consistent homogeneously mixed fresh material e.g., pan mixer or continuous mixers
Mortar Pump	Suitable capacity to convey the fresh material to the print head and nozzle
Rotor-stators	Assortment with different ratings depending on grain size, print speed, line geometry, pressure, and desired output rate. Keep spares.
Hose	Variety of different lengths depending on distance between mortar pump and print head. Different diameters depending on throughput, print speed and line geometry
Print head	Optional chamber that collects fresh material from hose conveying it to the nozzle
Nozzles	Variety depending on print speed line width and geometry

8.5 SUITABLE TYPES OF MIXING EQUIPMENT

The type of mixer shall have an accurate powder and water dosing and shall ensure a thoroughly homogeneous mixed material.

In selecting the mixing equipment consider.

- Suitability for use with mineral binders
- Suitability for the maximum grain size
- Accuracy of the powder addition
- Accuracy of the water addition
- Continuous and stable water content
- Type of mixing paddle
- Adjustable motor size and mixing speed (RPM)

In 3DCP the mixing is often a semi-continuous process meaning the mixing output is faster than the pumping output and extrusion rate.

With all equipment there may be optional extras like sensors, which are to be discussed with the equipment manufacturer or supplier.

8.5.1 FORCED ACTION PAN MIXERS

There are a variety of forced action pan mixers. Always discuss with the equipment manufacturer the suitability for use with 3DCP. These are not suitable for accelerated or fast setting materials.



FORCED ACTION PAN MIXERS

FEATURES

- Accurate water content
- Thorough mixing ensured
- Homogenous material
- Mixing multiple bags reduces fluctuations
- Easy to add additions (e.g., additives, fibers, colours)

CHALLENGES

- Different results from different mixers
- More waste at the end of printing
- Dried material lining equipment
- Labour intensive

Notable differences in line quality due to:

- Measuring water and powder errors
- Energy from mixing
- Material temperature fluctuations
- Paste leaking from worn seals
- Different mixing times
- Different standing times

8.5.2 CONTINUOUS MIXERS

There are a variety of continuous mixers. Always discuss with the equipment manufacturer the suitability for use with 3DCP.

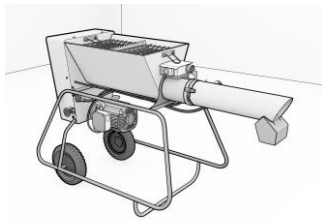

CONTINUOUS MIXERS

FEATURES

- Multiple sizes and outputs
- Small, light, and portable
- Very fast mixing process
- Adds water early stage
- Adjustable water flow
- Fast reaction to water change
- Continuous flow of material
- Lower waste

CHALLENGES

- Designed for gypsum, renders, screeds
- Different varieties of mixing time
- Water fluctuations
- Powder feed
- Variable mixing time
- Semi-continuous mixing
- Requires constant filling and monitoring

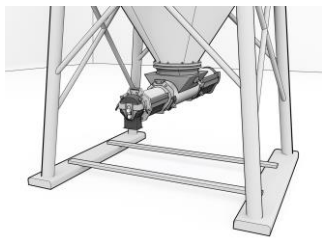

SILO MIXERS

FEATURES

- Multiple sizes and outputs
- Very fast mixing process
- Adjustable water feed
- Continuous flow of material
- Low waste
- Less labour intensive
- Manufacturer support

CHALLENGES

- Different varieties of mixing time
- Powder dosing flow rate
- Water fluctuations
- Variable mixing times
- Powder arching in silo

8.6 UNSUITABLE MIXING EQUIPMENT

There are some equipment's that should not be used for mixing Sikacrete® 3D 1-component materials.

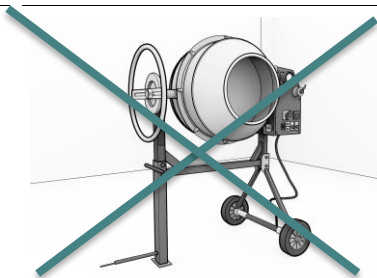
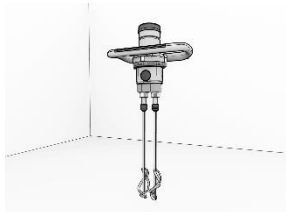

Hand mixing is not suitable for thixotropic materials, or where a consistent quality is required.

Hand mixing may be suitable for materials with a lower viscosity, for small printing equipment where one mix is sufficient for printing the object.

The right paddle selection is important and double paddle mixers are recommended.

Tumble mixers shall not be used to mix Sikacrete® 3D materials

Low power type mixers with stirring paddles will not have sufficient energy to mix higher viscosity materials.

8.7 SUITABLE TYPES OF PUMPS

There are different types of pumping equipment suitable for small grain mineral binders which convey fresh material through a hose to the point of extrusion.

From the list of pumping equipment there is only one which generally is being used for 3DCP, and this is the eccentric screw pump. Other pump types produce an oscillated flow which is more prominent with short hoses.

- Eccentric Screw Pump/Worm Pump/Schnecken pump
- Piston Pumps
- Peristaltic pumps
- Rotor pumps
- Double Piston Pumps
- Squeeze Pumps

If the pump is connected directly to the nozzle, then the material needs to be a constant flow. If the pump feeds an intermediate chamber at the print head, then other pumps may be possible but must be checked.

The selected pump shall be suitable for the material grain size and the output rate.

Stronger pumps may be required if the pipe length is long, or the hose has a larger diameter or if the point of extrusion is at an elevated height.

8.7.1 ECCENTRIC SCREW PUMP

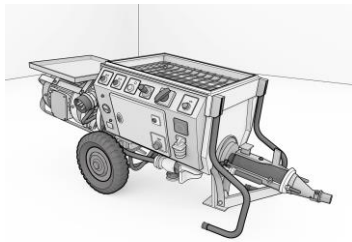

ECCENTRIC SCREW PUMP/WORM PUMP/SCHNECKEN PUMP

FEATURES

- Different sizes available
- Pumps high viscosity material
- Conveyance with low pulsation
- Constant flow
- Adjustable output
- Additional mixing in hopper
- Helps de-aerate material

CHALLENGES

- Selecting the right speed
- Selecting the right rotor-stator
- Back pressures
- Temperature increase
- Stoppages
- Material arching over screw

8.8 COMBINED MIXER PUMP EQUIPMENT

The following continuous mixer pumps are more frequently used for 3DCP and recommended for use with Sikacrete® 3D materials. Refer to chapter 14.

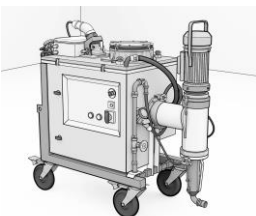

CONTINUOUS MIXER PUMPS

FEATURES

- Purpose built for 3DCP
- Manufacturer support
- Automated settings
- Adjustable motor speeds
- Very rapid material mixing
- Adjustable water flow
- Quick changes to workability
- Adjustable output
- Less waste
- Sensor measurements

CHALLENGES

- Adjusting water to powder ratio
- Semi-continuous mixing
- Powder feed
- Constant monitoring
- Equating water from l/hr to a % by weight powder
- Thorough cleaning
- Different settings for new materials

SILO CONTINUOUS MIXER PUMPS

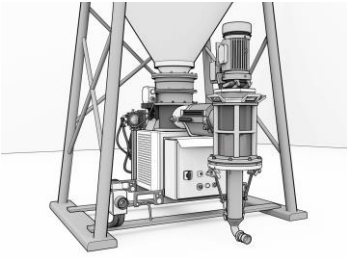

FEATURES

- Purpose built for 3DCP
- Manufacturer support
- Automated settings
- Automatic silo powder feed
- Separate mixing and pump
- Adjustable motor speed
- Very rapid material mixing
- Quick changes to workability
- Less waste
- Further sensors can be added
- Less labour intensive

CHALLENGES

- Not all equipment's are the same
- Water flow l/hr different between equipment
- l/hr not equating to a % wt powder
- Only way to check water content with a drying test
- Powder feed
- All materials require pre-testing

8.9 UNSUITABLE MIXER AND PUMPS

8.9.1 COMBINED FORCED ACTION MIXER WITH PUMP

There are different types of combined forced action pan mixers and pumps on the market. These are generally used for spraying plasters and mortars and not specifically designed for 3DCP.

FORCED ACTION PAN MIXER AND PUMPS

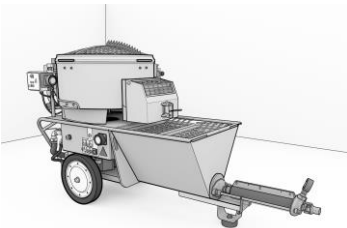

FEATURES

- Measured water content
- Thorough mixing ensured
- Homogenous material
- Mixing multiple bags reduces fluctuations
- Easy to add additions (e.g., additives, fibers, colours)

CHALLENGES

- More waste at the end of printing
 - Dried material lining equipment
 - Labour intensive
- Notable differences in line quality due to:
- Measuring water and powder errors
 - Energy from mixing
 - Material temperature fluctuations
 - Paste leaking from worn seals
 - Over mixing
 - Standing times

8.9.2 CONTINUOUS MIXER PUMP

As described, some combined mixer-pumps can be used for 3DCP although there are some types which may found to be more challenging.

The difficulty with mixer pumps that use the same motor for the mixing and pumping is to find the right mixing speed and pumping speed together.

When considering if an equipment is suitable for 3DCP, it is important to consider.

- Powder feed
- Water feed
- Homogenous mixing
- Controllable mixing speed
- Controllable pumping output

Generally high mixing speeds will elevate the material flowability. This gives the feeling the viscosity is high, and the immediate reaction is to lower the water dosage. Lowering the water gives the lines a dry appearance and therefore it can be difficult to find a suitable mixing and printing setting.

METHOD STATEMENT

3D Concrete Printing using Sikacrete® 3D products

Oct 2023, Release 1

Copyright Sika® 2023

English version/Corporate

EN editor D Taylor

This type of equipment is therefore not recommended for use with Sikacrete® 3D 1 -component products.

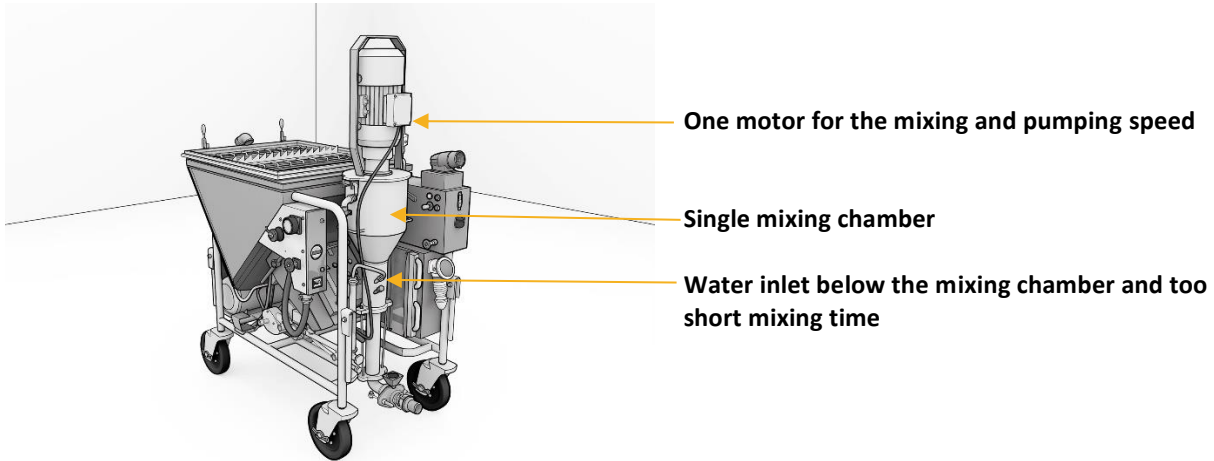

8.10 CLEANING TOOLS

The following tools are required for cleaning but not limited to. Always refer to the equipment manufacturer’s recommendations for cleaning and maintaining the equipment.

Paper towels and cloths	For wiping and drying
Sponges, mops, swobs and wipes	Wet and dry variety for floor cleaning, wiping equipment etc
~30l large bucket or pail (several)	For collecting excess fresh material
Miscellaneous domestic buckets	Selection of different sizes for rinsing and cleaning
Dust pans and brushes	For removing dried material
Vacuum cleaner	Suitable dust extraction system
Hose pipe and spray nozzle	Suitable for a domestic water supply
Pressure water jet	For thorough cleaning of the equipment. For type, refer to equipment manufacturer’s recommendations.
Hand brushes	Variety of sizes and types, for example <ul style="list-style-type: none"> ▪ Soft plastic ▪ Nylon ▪ Animal hair ▪ Brass ▪ Steel wire
Wash water sump	Suitable filtering and drainage system for separating cement and sand particles from the water before neutralizing and discharging. Refer to relevant local regulations and legislation requirements.
Sponge balls	For inserting in the hose for cleaning purposes, refer to the equipment manufacturer’s recommendations.

8.11 PRINTING ANCILLARIES

It is recommended to have the following for printing but is not limited to this list.

Printing platform	A stable non-stick flat surface to print on
Suitable curing technique ⁽²⁾	For controlling volume change during plastic and hardening phases ⁽¹⁾
Polythene sheets or roll	For protecting surfaces from splashes and spillages from the material.
Waste disposal	For unused hardened material and contents of the wash water sump

(1) Some curing techniques can cause staining or different appearances and shall be pre-tested.

(2) Refer to section 10.3

8.12 ADDITIONAL TOOLS







There are other miscellaneous tools which may be required to help a successful concrete printing which are not limited to this list.

Pallets	For moving printed objects
Vice and clamps	For general purpose for example the rotor-stator assembly
Work bench or table	For general purpose and performing QC
Lubricant and equipment protection	For maintaining the printing equipment Refer to equipment manufacturer's recommendations
Handheld drill	For mixing lubricant, loosening, or tightening screws or bolts

9 PRINTING PREPARATION

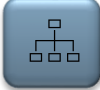
9.1 BASIC PROCEDURE

The basic procedure for printing preparation is discussed in this chapter.

-  1. Evaluate working conditions
-  2. Prepare the equipment
-  3. Prepare the material
-  4. Lubricate the hose
-  5. Program the printing object
-  6. Find the printing workability
-  7. Start with a test print

Keeping records throughout the printing process will bring better efficiency in selecting the right settings for future printing.

Some 3DCP equipment are available with sensors that will record in real time certain parameters on the equipment, otherwise making manual measurements are highly recommended.

Any record about a printing session shall start with a minimum basic information about the print and is not limited to the following list.



- Print reference
- Operator name
- Date
- Robotic arm or gantry model type or reference
- Mixer model or reference
- Pump model or reference
- Rotor stator model or reference
- Hose length, number of sections and diameter
- Nozzle diameter, model, or reference

9.2 EVALUATE WORKING CONDITIONS

Mineral binders, especially cement, are well known to be sensitive to temperature and humidity fluctuations and the mixing water will require adjusting accordingly during the printing process. Generally, the colder the temperature the material will become slower setting and hardening. The warmer the temperature the material will become faster setting and hardening.

Remember! Mineral binders, especially cement, are sensitive to water and temperature fluctuations

The Operator will also observe as the equipment warms up from a cold start this exerts energy to the material which also increases in temperature. At this point the water dosage will need adjusting.



For consistent printing, it would be best to climatise an inside ambient temperature at approximately $+20^{\circ}\text{C} \pm 2^{\circ}\text{C}$ throughout the whole year. This would contribute to a more stable, reliable process and help reduce some fluctuations in the fresh material properties and printed object quality.

However, in practice it is widely accepted that maintaining a single temperature is not always possible and therefore one exact recipe for all material, ambient and equipment temperature conditions is not generally possible.

To maintain as best possible stable printing operation and good quality printing the material and ambient temperatures in a PDS are given in a range. Printing in ambient temperatures outside of this range may be possible although further measures may be required to stabilise the printing process.

A recommended ambient temperature range for the equipment will also be defined by the equipment manufacturer and shall be followed.

Sikacrete® 3D 1-component products are available for different ambient printing conditions. There are products for printing in warm conditions and accelerated products for cooler conditions. Refer to the most current PDS for the recommended ambient temperature range or contact your local Sika® Technical Department for further guidance.

Always measure and keep records of the ambient temperature and relative humidity at start of preparation and at regular intervals until the printing is finished.

If printing outside record the general weather conditions, temperature, and relative humidity, including wind strength and direction in relation to the print. Protect the equipment from rain or strong wind. Do not allow the material packaging to become wetted.

Do not expose the mixing, pumping equipment, or hose to direct sunlight. Protect the mixing and pumping equipment from wind and rain.

In extreme warm conditions, use a cover to shade the equipment, consider using a white hose pipe and maintain a moist material over the top of the hose to prevent it from heating up.

The quality control for the ambient conditions for a record shall contain, but not limited to.



- Temperature at start
- Relative humidity at start
- External* ambient conditions at start
- Temperature at intervals
- Relative humidity at intervals
- External* ambient conditions at intervals
- Temperature at end
- Relative humidity at end
- External* ambient conditions at end

* If relevant

Working space shall be sufficient in size, clean and tidy with no obstructions. Provide access around the mixer and pump especially if material handling equipment is required to lift big bags.

Working areas shall be well illuminated.

9.3 PREPARING THE EQUIPMENT

The equipment shall be suitable for 3D concrete printing. The selection of mixing and pumping equipment shall be suitable for the Sikacrete® 3D material, taking into consideration:

- Maximum grain size
- Mixing time
- Open time
- Printing requirements

The equipment shall be capable of combining accurately Sikacrete® 3D with a defined water dosage mixing thoroughly into a suitable workability and conveying the fresh material at a constant flow through a hose to the print head and nozzle where it can be extruded at a constant flow.

The pump machine and ancillary equipment shall be of adequate capacity for the volumes to be applied. The equipment shall have been tested prior to the main work for compatibility with the Sikacrete® 3D 1-component product.

All moving parts, fittings, seals, and surfaces shall be inspected for cleanliness or damage before use. Carefully remove any hardened material before starting in accordance with the equipment manufacturer's recommendations.

The equipment shall not leak.

Calibrate the equipment regularly in accordance with the equipment manufacturer's recommendation.



Assemble the equipment in accordance with the manufacturer's recommendations. For consistent printing, define an assembly procedure and keep to the same routine every time.

A quality control for preparing the equipment can be a check list, to be signed off by the Operator during the assembly to ensure it has been completed correctly and nothing has been missed. Keep records of the quality control for future reference.



- Assembly start time
- Equipment cleanliness
- Material prepared
- Water prepared
- Mixer prepared
- Pump prepared
- Rotor stator prepared
- Hose prepared
- Nozzle prepared
- Assembly end time

Any faults, damages, observations, adjustments, or modifications shall be recorded at the end of the check list.

The Operator shall be trained and familiar with the use of the equipment and material. Always read the equipment manufacturer’s instructions before use. It is recommended even for experienced operators to define an assembly procedure and stick to the same routine when assembling the equipment.

Power for the equipment shall be approved for use. Refer to the equipment manufacturer’s instructions.





9.3.1 FORCED ACTION PAN MIXER

It is recommended to use a pan mixer for small 3DCP equipment where one mixed batch is sufficient for the print. For larger volumes, a continuous production process will need to be developed.

Caution! Not suitable for fast setting or accelerated materials

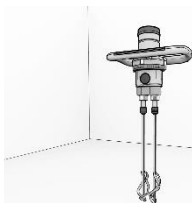
Use a suitable sized pan mixer according to the throughput and printing speed. If the throughput to the nozzle is faster than the mixing process, consider using a larger pan mixer or more than one pan mixer. If the printing is slower than consumption of the material, consider mixing a smaller quantity or using a smaller mixer.

Different pan mixers have different mixing energies. The temperature of the material will increase during mixing due to the material, water dosage, degree of mixing energy and the mixing time. The higher the material temperature increases, the faster the material reaction and shorter the material’s pot life.

DOUBLE PADDLE MIXER ~400 rpm	EXAMPLES OF FORCED ACTION PAN MIXERS		
	~100 – 120 litres capacity	~250 litre useable capacity	~350 litre useable capacity
			

Use the same type of pan mixer if using more than one. Different pan mixers have different mixing energies, and this will be evident in the printed lines.

Do not mix less than the minimum recommended by the equipment manufacturer.



For consistent printing the time taken after mixing to extrusion through the nozzle needs to be approximately the same, otherwise the different batches will be evident in the printed lines.

Always discuss with the equipment manufacturer the pan mixer suitability for 3DCP.

9.3.2 CONTINUOUS MIXERS

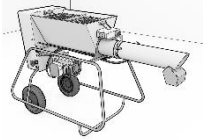

Continuous mixers can be used for short or long printing sessions. Although these types of mixers can mix material continuously often is the case this is a semi-continuous mixing process that requires starting and stopping. The main reason for this is because continuous mixers can produce more fresh mixed material than is extruded by the nozzle.

The adequacy of mixing depends on the type of mixing tool, length of mixing chamber and throughput flow. The mixing shall ensure the complete, consistent, and thorough mixing of the material.

The mixing shall not increase the temperature of the material significantly.

The water flow shall be adjustable in small amounts to an accuracy approximately 0.1 litres/min.

Always discuss with the equipment manufacturer the continuous mixer suitability for 3DCP.

9.3.3 PUMPING EQUIPMENT

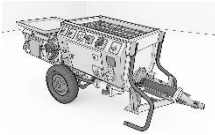

The pump shall be adequate to convey the fresh material to the print head or nozzle.

The drive motor speed (RPM) shall be adjustable to cover the desired print output based on the print speed, layer width and layer depth. Refer also to 9.3.4.

The motor speed shall be adjusted in a range between a minimum and maximum setting so that there is the possibility for adjustment. It is not recommended to use the slowest or fastest pump setting. The range depends on the equipment type and rotor-stator type.

It is recommended to use a pressure gauge with the pump and monitor the reading during the printing process.

Always discuss with the equipment manufacturer the pump suitability for 3DCP.

9.3.4 ROTOR-STATOR

The correct rotor-stator selection is highly important to the success of the 3D concrete printing.

The rotor-stator shall be capable of conveying the material through the hose at a constant uninterrupted flow rate.

Caution! A cause of printing failures is the wrong rotor-stator selection

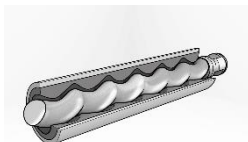

The rotor-stator consists of two parts. The rotor is a spiral steel shaft that creates chambers to convey the fresh material along. The stator is moulded synthetic or rubber with a metal casing that the rotor is twisted into. After

The rotor-stator manufacturer or supplier will need to know the following information for recommending a suitable rotor-stator.

1. The pump type
2. Maximum grain size of the material
3. Required flow rates
4. Pump motor speed (min and max)

The rotor-stator is selected on:

1. Stator diameter
2. Stator length
3. Rubber quality expressed as a shore hardness
4. Flow rate expressed with a defined pump motor speed in RPM
5. Maximum allowable grain size

The required flow rate can be estimated.

How to estimate the required flow rate.	
Example:	Printed volume:
Print speed 100 mm/sec	100 x 10 x 25 = 25,000 mm ³ /second
Lines 10 mm thick x 25 mm wide ⁽¹⁾	Equating to 90 l/hour or 1.5 l/min ⁽²⁾

(1) theoretical shape based on a rectangular cross section, which is not the case.





(2) 1 mm³/sec equal to 0.0036 l/hr

As an example the table illustrates the theoretical extrusion rates of printed layers in related to the print speed.

LINE DIMENSION mm wide x mm deep	THEORETICAL SECTIONAL AREA mm ²	PRINTING SPEED mm/second			
		50	100	250	500
20 x 5	100	0.3 l/min	0.6 l/min	1.5 l/min	3.0 l/min
40 x 10	400	1.2 l/min	2.4 l/min	6.0 l/min	12.0 l/min
50 x 15	900	2.3 l/min	4.5 l/min	11.3 l/min	22.5 l/min

Table 9.3.4. 1 indicating the theoretical extrusion flow based on a print line speed and line width and depth

A starting point for the rotor-stator selection could be as follows although must be checked.

	Approx. 3 l/min
	Approx. 4 to 5 l/min
	Approx. 8 to 10 l/min
	Approx. 15 l/min
	Approx. 25l/min

A degree of energy will be produced by the rotor-stator due to friction with the material. The size and shape of the rotor-stator, the hardness of the rubber will all affect the material temperature. The operator will observe an increase in the material temperature over time due to the pumping process. The amount of energy will increase with a larger grain size, lower material viscosity and longer printing time.

The rotor-stator shall not increase the material temperature significantly as this will increase pressure and cause a stoppage if the material dries.

Always monitor the temperature and pressure changes between the freshly mixed material and the extruded material. The operator will learn when the temperature for a material has increased to a point when the printing is best stopped, equipment cleaned and re-started.

The rotor fits tightly into the stator and the print quality will vary depending on if the rotor-stator is new or worn. After long use the tight fit of the rotor in the stator will loosen meaning the pump flow rate will reduce.

Always check the condition and wearing of the rotor-stator before use. Test the functionality of the rotor-stator regularly as recommended by the equipment manufacturer. Replace a worn stator.

Keep a record of the number of hours a rotor-stator has been used. With experience this will give an indication when the stator needs to be replaced.



For consistent printing, prepare, assemble, and tightened the rotor-stator the same for every print in accordance with the equipment manufacturer's recommendations.

Keep spare rotor-stators in reserve. For each print record the rotor-stator details for future reference.

For quality control, record information about the rotor-stator and observe any changes in the printing quality.



- Rotor-stator model or reference
- Visual condition of the stator before starting
- Assembly and tightening procedure
- Pump speed
- Operational time of the rotor-stator
- Visual condition of the stator after printing

Always discuss with the equipment manufacturer the rotor-stator suitability for 3DCP.

9.3.5 HOSE PIPE

The diameter of the hose or pipe shall be uniform throughout. Do not use reducers or sharp bends to connect hoses. The hose or pipe shall not have any dents or kinks and be long enough to reach from the pump to the print head and nozzle.

Replace damaged or defective hoses.

Use a white hose pipe in extreme warm conditions or cover with a cloth material while maintaining wet with cool water.

Use the shortest hose length possible to reduce the risk of stoppages and reduce the amount of waste at the end of printing.

9.3.6 NOZZLES AND PRINT HEADS

Nozzles are out of scope of this Method Statement; although, nozzle selection is as important as selecting the right recipe. The nozzle diameter is selected according to the material output and print speed, as well as the pipe diameter, object design and of course desired layer width.

Generally, round nozzles are fixed in an x-y axis and rectangular nozzles may be rotational. This means rotational rectangular rotational nozzle can maintain a constant layer thickness. None-rotational nozzles will produce a constant line thickness in a straight line, but in corners and curves the speed on the outside of the line is faster than the inside of the line. This may result in variable line thicknesses on the inside and outside of the line and shall be considered when programming the slicing.

The nozzle shall be similar cross section area (rectangular nozzles) or diameter to the pipe. Nozzles which reduce the flow from the pipe can start a backpressure in the hose. This can lead to a pressure build-up in the rotor-stator, causing an increase of pressure and increase in material temperature over time. This is typically the case with thixotropic materials, or with a lower water dosage. Over longer printings time this may result in a stoppage.

9.4 PREPARE THE MATERIAL

Condition the material at least 24h before use. If printing outside, condition the material inside as long as possible until ready to use.

Do not store the material in direct sunlight.



For consistent printing, it would be best to condition the material at a temperature of approximately +20°C. This would help to reduce fluctuations in the fresh materials properties.

However, in practice it is widely accepted that maintaining a single temperature is not always possible.

To maintain as best possible stable printing operation the material and ambient temperatures in the PDS are specified in a defined range. Printing in ambient temperatures outside of this range may be possible although further measures may be required to stabilise the printing process.

Use only clean potable water for mixing with Sikacrete® 3D materials.

If sourcing water from a main supply consider the water temperature will fluctuate depending on if the water is drawn early in the morning, midday, the afternoon or at night.



For consistent printing use water at a temperature approximately $+20^{\circ}\text{C} \pm 2$. To overcome the water temperature fluctuations consider using a water bowser or other storage system to supply mixing water that can be regulated to the recommended temperature.

If the material cannot be conditioned to the recommend temperature use cold water in extreme warm printing temperature conditions and warm water in extreme cold printing temperature conditions with the target to achieve approximately $+20^{\circ}\text{C} \pm 2$ fresh material temperature after mixing.

Do not use water with temperature below $+5^{\circ}\text{C}$ or above $+30^{\circ}\text{C}$. If using ice to reduce water temperature, make sure frozen water is not mixed directly with the Sikacrete[®] 3D material.

Water supplied directly from the mains to a continuous mixer shall have a stable pressure during the printing process. Any fluctuations from the mains supply will increase or decrease the dosage amount and will be observed in the print quality. Refer to the equipment manufacturer’s instructions for the water pressure requirements.

For quality control, log the temperature of the materials. Keep records of the quality control for future reference.



- Sikacrete[®] 3D temperature at start
- Water temperature at start
- Water temperature at intervals
- Water temperature at end

9.5 LUBRICATE THE HOSE PIPE

Always lubricate the hose pipe before starting using Sika[®] Pump-Start 1 or a cement slurry.

Caution! Always lubricate the hose before printing

The cement slurry mix shall not sediment due to excess mixing water.

Sika[®] Pump-Start 1 is a polymer that pre-wets the hose to reduce the chance of stoppages and reduces the pressure needed for pumping. Refer to the Sika[®] Pump-Start 1 PDS for further Product information.

STEP	DESCRIPTION
1	Prepare a bucket with approximately 10 litres of water and add 70g (ratio 1:6.7 Product(g) to water(litre) of Sika [®] Pump-Start 1 according to the Sika datasheet and mix it until it is homogeneous.
2	The pump hopper shall be clean. Place the 10 litres in the pump hopper and pump slowly the lubricant through the hose to waste
3	When the lubricant is at the minimum level in the pump add the material in the pump hopper and continue pumping until there is no more lubricant.
4	Some material will need to be pumped to waste if it contains lubricant

9.6 PROGRAM THE PRINTED OBJECT

Drawing, object design, slicing and operational use of the software are out of scope of this Method Statement.

When starting the equipment from cold it is recommended to print a test object first to check the equipment settings, material workability and print quality. This has the added benefit of comparing settings in different conditions and helps to warm up the equipment before proceeding to the main print.



9.7 FIND THE RIGHT MIXING WORKABILITY

The operator shall understand, often by experience what effect of altering the machine settings and using different tools has on the printing quality.

ACTION	FEATURES	CONSIDERATIONS
Increasing water ⁽¹⁾	<ul style="list-style-type: none"> ■ Lower material viscosity ■ Low pump pressure ■ Decreases dry appearance ■ Easier/faster to mix 	<ul style="list-style-type: none"> ■ Strength decrease ■ Risk segregation in the pump and hose ■ Slower curing ■ Lower buildability rate ■ Increase cracking potential
Decreasing water ⁽¹⁾	<ul style="list-style-type: none"> ■ Increases strength ■ Increases viscosity ■ Lower cracking potential 	<ul style="list-style-type: none"> ■ More sensitive in low humidity conditions ■ Dry print appearance ■ More air in line ■ Increase equipment wear ■ Risk of stoppage ■ More pump pressure
High mixing speed	<ul style="list-style-type: none"> ■ Faster mix time ■ Lower viscosity ■ Easier to pump 	<ul style="list-style-type: none"> ■ Faster reactivity ■ Increasing material temperature ■ Shorter open time ■ Entraining more air
Low mixing speed	<ul style="list-style-type: none"> ■ Slower reactivity ■ Less material temperature increase ■ Longer open time 	<ul style="list-style-type: none"> ■ Insufficient mixing ■ Lower homogeneity ■ Higher viscosity ■ More equipment wearing ■ Drier lines ■ Risk of stoppage

(1) outside the recommended PDS range

Mixing with a high RPM can give a false workability indication. High energy mixing will cause the material to appear to have low viscosity and higher fluid appearance. The tendency is to lower the water dosage which only results in a dry printed appearance and possible stoppage.

Do not mix Sikacrete® 3D material with the highest mixing speeds. This also depends on the type of mixing paddle and mixing energy.

9.7.1 FORCED ACTION PAN MIXERS

This method is not suitable for use with accelerated materials

Pre-planning is essential to the printing success when using pan mixers. It must be ensured.

- Sikacrete® 3D material and water are prepared before starting
- The equipment is well prepared
- There is no interruption in the material supply during printing
- Mixed batches are not standing for different lengths of time



To ensure precise mixing pre-prepare containers containing the right amount of Sikacrete® 3D material in sufficient quantity for the printing session. Using scales, measure the Sikacrete® 3D to the required weight. The amount in kg in each container depends on manual lifting and the pan mixer capacity.

Do not exceed the maximum manual handling weight according to local regulations or laws.

For the recommended water ratio refer to the most current Sikacrete® 3D PDS. Do not use water beyond the stated maximum and minimum limits.

Mix the material in accordance with the PDS.

Always monitor the material temperature after mixing and take into consideration the ambient temperature and relative humidity when determining the pot life.

Pot life on the data sheet is an indication and shall be determined more accurately by tests and experience during the printing session according to the conditions.



Check during mixing that the material is homogeneously mixed and that there is no remaining powder around the edges, in the corners or on the paddles.

It is recommended to check each mixed batch using a spread flow test for quality control. The water dosage may need adjusting if the result of the spread flow test changes.

Remember! When the material has been mixed, it is starting to react

As a guide the material temperature after mixing should not increase significantly from the un-mixed material temperature. If the material temperature starts to increase higher then consider reducing the mixing speed or cool the water.

The material temperature will further increase due to pumping through the rotor-stator and friction through the hose and nozzle. This shall also be taken into consideration when defining a maximum material temperature after mixing.

GENERAL PAN MIXING PROCEDURE

Refer to the Sikacrete® 3D for the minimum and maximum water dosage.

To calculate the water mixing ratio from the PDS information.

Equation 1: Dry powder quantity 25 kg x PDS dosing value e.g., 14% = 3.5 litres of water per 25 kg powder

Before starting, always calibrate the scales with a known weight. Remember to zero the scales with the empty bucket or container before filling.

Mixing procedure for 1-component products in quantities less than 25 kg

1. Accurately measure the powder weight
2. For the first mix, accurately measure the minimum recommended water dosage into a container
3. Accurately measure into a second jug the remaining water to the maximum recommended dosage
4. Pour 2/3rd of the water into the pan mixer, ensuring there are no leaks
5. Carefully add the powder and remaining water
6. Mix for approximately 1 minute or until all the powder is wetted
7. Stop the mixing and check around corners, edges, and paddles for un-mixed powder
8. Continue mixing for the remaining recommended time, refer to PDS
9. Check material temperature
10. Take a sample and check the workability using the spread flow test
11. If the workability needs more water add a small amount evenly to the mix and re-mix for 30 seconds
12. Repeat the tests
13. Transfer to the mortar pump when the workability is satisfactory

The first mix batch is usually the test mix and may have required the addition of more water to find the right workability. If additional water was added, adjust the water amount for the second mix. Keep records of the temperature, mixing time and water dosage for future reference.

Mixing large quantities always depends on the mixing torque of the equipment. Always refer to the equipment manufacturer's recommendations before starting.

The mixing of multiple bags and larger quantities shall be accurate or different batches will be noticeable in the printed lines.

1. Accurately measure the powder material in manageable amounts
2. Accurately measure the minimum recommended water dosage into manageable amounts
3. Accurately measure into a second container the remaining water to the maximum recommended dosage
4. Pour 1/4 the water into the pan mixer, ensuring there are no leaks
5. Slowly add all the powder and add the remaining water evenly on top
6. Mix for approximately 1 to 2 minutes or until all the powder is wetted
7. Stop the mixing and check around corners, edges, and paddles for un-mixed powder
8. Continue mixing for the remaining recommended time approximately 3-5 minutes
9. Check material temperature
10. Take a sample and check the workability using the spread flow test
11. If the workability needs more water add a small amount evenly to the mix and re-mix for 30 seconds
12. Repeat the tests
13. Transfer to the mortar pump when the workability is satisfactory

Remove as much mixed material from the pan mixer as possible as remaining paste will affect the workability of the next batch and this will be evident in the printed lines.

For quality control, record the procedure, material temperature and spread flow results. Keep records of the quality control for future reference.



- Quantity of dry component per batch
- Water quantity per batch
- Time at start of mixing
- Time at end of mixing
- Material temperature after end of mixing
- Spread flow result
- Observations and recommendations for next batch

9.7.2 CONTINUOUS MIXERS

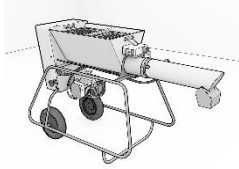

The dry material is placed in the hopper and conveyed into a mixing chamber where water is added. The water is usually regulated by a valve or electronically and measured as a flow rate in litres/minute.

The fresh material workability is a combination of selecting the appropriate throughput screw for the dry material and by adjusting the water.

Maintain the dry hopper full to keep the same amount of pressure on the throughput screw. This will ensure a similar amount of powder is being conveyed into the mixing chamber. Do not expose the throughput screw as this will feed air into the mixing chamber, create dust, decrease the powder content in mixing and therefore increase the water ratio which will be evident in the printed lines.

Generally, an experienced operator can determine the desired workability by the visual aspect and check it by printing a test object.



For consistent printing, always check the workability using the spread flow test and determine the water content using the microwave test.



Determining the water content using the microwave method

Water content % = ((fresh material weight – dry weight) / dry weight) x 100

For example: (320 g – 278 g) / 278 = 15.1%

Take into consideration there is a time delay from making any adjustment until the new workability is observable. To reduce waste, use a short hose length to find the desired workability.

If the desired water flow is known, always start with approximately +10% water, and then reduce slowly to the desired workability to reduce the chance of a stoppage.

Repeat the spread flow test at regular intervals while printing, or at minimum at the start and end of printing. Compare the results with other parameters such as material temperatures, equipment pressure etc.

For quality control record the equipment settings for the printable workability.



- Throughput screw model or reference
- Motor speed setting (RPM)
- Water dosage l/min
- Workability at start of printing
- Water content at start of printing
- Workability at intervals
- Workability at end of printing
- Water content at end of printing

9.8 START WITH A TEST PRINT

It is recommended to print a same object as a benchmark for checking the equipment and water dosing settings.

- At the start of each new day
- Beginning from a cold standing
- Changing to new material production date
- Changing Sikacrete® 3D materials

This is a fast indication if material and equipment are working well whilst checking.

- Water dosage
- Setting time
- Print quality
- Print accuracy
- Buildability rate

It also helps the equipment come to a working temperature before starting the main printing session.



An example would be to print a cylinder shape measuring 160 mm diameter x 320 mm high.

Use the test print to determine a suitable time for moving the object, when the layers cannot be pulled apart.

Alternatively, fill the printed object with material and use the test to check the compression strength after a defined time, like 1 day or 28 days.

A record of the print shall be written by the equipment Operator and filed in an accessible location.

A report shall contain the following minimum information.





REPORT

- | | |
|---|------------------------------|
| ➤ Operator name(s) | ➤ Layer thickness |
| ➤ Date and time of test | ➤ Number of layers |
| ➤ Product name and batch number | ➤ Printing start time |
| ➤ Ambient temperature and relative humidity | ➤ Curing method |
| ➤ Equipment tools | ➤ Results (observations) |
| ➤ Equipment settings | ➤ Conclusion |
| ➤ Layer width | ➤ Picture of printed element |

A suggested template is included in this method statement.

10 PRINTING

The basic procedure for printing is discussed in this chapter.

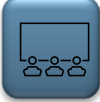
-  8. Start the printing
-  9. Optimise printing quality
-  10. Cure the printed objects
-  11. Moving the printed objects
-  12. Final use of the printed object

10.1 START THE PRINTING (APPLICATION)

10.1.1 PRINTING PLATFORM

The printing platform shall be clean, level, and stable.

If the printed object is to be moved, place the printing platform on a suitable base, such as a pallet, which can be carefully moved around using the material handling equipment.

The temperature of the printing platform will influence the setting time of the first layers, especially if the surface is cold, it will slow down the material setting time effecting the initial buildability rate.



For consistent printing, condition the printing platform a minimum 24 hours before use at a temperature of $+20^{\circ}\text{C} \pm 2$.

At very warm temperatures it is better to use a cooler platform surface and very low temperatures to use a warmer platform surface.

10.1.2 PRINT STABILITY

The design of the object shall be achievable for the equipment and material.

Factors affecting print stability of the Sikacrete® 3D material.

- Min and max interlayer time
- Initial setting time
- The print height
- The line slenderness
- Shape
- Overhangs (printing at an angle)
- The strength development

10.1.3 FORCED ACTION PAN MIXERS

If the water dosage needs increasing, always add additional water during the mixing time. Adding more water to the mixed batch after the material has been standing will be reflected in the line quality.

Do not add additional water in the pump unless there is a stoppage, and the printing must be halted.

Regularly check the material temperature and compare any significant increase with a workability test.

Mixing energy will influence the material setting. A high mixing energy accelerates the material setting and low mixing energy may not be sufficient to produce a homogenous material.

The material temperature shall not increase significantly above the initial material temperature. If the material increases notably this will reduce the pot life and can influence the pumping process.

Measures to reduce the fresh material temperature due to the mixing process

- Reduce the mixing energy
- Reduce the mixing time slightly
- Use cooler water
- Consider using a different equipment

Remember any water dosage changes will not take effect until the new batch is being extruded.

Consider materials with a long open time or small quantities are more suitable with forced action pan mixing method. Consider also this method may be better suited for cooler ambient temperatures and not warm climates.

10.1.4 CONTINUOUS MIXERS

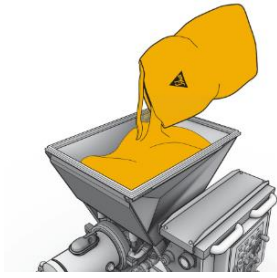

Always maintain material in the hopper.

If the material does not look suitably mixed, consider changing the mixing tool and check the mixing speed. Consult the equipment manufacturer.

If there is unmixed powder, check the water inlet is not blocked or issue with the water supply.

Adjust the water flow in small increments. Do not adjust the water flow and pumping through-put at the same time. Only adjust one setting at a time.

Regularly check the material temperature and compare any significant increase with a workability test.

Mixing energy will influence the material setting. High mixing energy accelerates the material setting and low mixing energy may not be sufficient to produce a homogenous material.

The material temperature shall not increase significantly above the initial material temperature. If the material increases notably this will reduce the pot life and can influence the pumping process.

Check the water content using the microwave test for each change of water dosage and record the results.

10.1.5 PUMPS

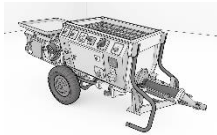

The hopper in the pump shall be maintained filled between the minimum and maximum level indicator. Refer to the equipment manufacturer's information.

Should the material drop below the minimum level this may bring air into the rotor-stator and pipe causing a non-continuous flow which will be evident in the printed layers. Any air in the hose shall be purged until the line quality is stabilised again.

Select the appropriate rotor-stator based on the required throughput and extrusion rate. It is not recommended to use a rotor-stator for the highest output using the fastest pump motor speed or smallest rotor-stator with lowest pump speed. It may be preferential to use a rotor-stator and pump speed within a mid-performance range so there is scope for adjusting during the printing process. Refer to the equipment manufacturer's information for a recommended pump speed range suitable for 3DCP.

It is recommended to use a pump with a pressure gauge to monitor the pressure during printing. A normal printing pressure is approximately between 5 to 25 bar depending on the material extrusion rate, length, diameter of hose, the lifting height, and the viscosity of the material.

Typically, the printing pressure shall not exceed 30 bar. If the pressure exceeds this value, it may be advisable to stop printing and investigate the cause of the high pressure. Do not exceed the maximum allowable pumping pressure specified by the equipment manufacturer.

The pump pressure will gradually increase from the start of printing and reach a stabilised value. The pump pressure may fluctuate slightly around this stabilised value which may be considered normal.

Rapid pressure fluctuations and varying pumping speed is an indication the pump is not running smoothly. This may be due to a worn or loosely tightened rotor-stator, a back pressure, or a material flow issue. Stop the printing and investigate the cause of the pressure fluctuations.

Some measures which can help reduce fresh material temperature due to the pumping process.

- Increase the printing speed
- Stop printing, clean and re-start again
- Change to a larger rotor-stator using a lower motor speed (RPM)
- Check the nozzle and pipe diameters are not creating a back pressure

*If a stoppage occurs
always address material
in the hose and nozzle first*

10.1.6 POT LIFE

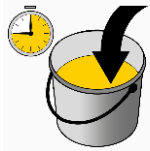

Determine the pot life according to all the conditions before deciding how long to let the material stand in the equipment.

Refer to the PDS for an indication of the pot life. Take all the conditions into consideration when estimating the pot life.

10.1.7 INTERLAYER TIME

Every material has a minimum and maximum interlayer time. The interlayer time is defined as the time taken to complete 1 layer in a complete circuit. If there is a variation in the interlayer time work to the minimum time.

Generally, the minimum interlayer time applies to objects printed greater than 0.7m vertically, with no overhangs or complicated shapes. The interlayer time may be reduced for vertically stacked objects less than 0.7m high, although this shall be checked on site, depending on temperatures, water content, line speed.

Consider the specified interlayer time will need to be increased for objects with overhangs or complicated shapes.

10.1.8 BREAKS



Breaks are not recommended, although may be necessary. It is not recommended to take breaks when using accelerated materials.

Pre-plan the time between printing different objects so that the material is not standing.

Do not stop and re-start printing longer than the determined pot life of the material, and then take extra care about the equipment and material temperature.

Check the rotor-stator temperature before stopping and re-starting as this may be a localised warm spot.

If the rotor-stator does not immediately start after a stop, remove, and clean; or replace with a spare rotor-stator.

After a stop and start check the workability of the extruded material using the workability test to see if it is still useable. If the standing material has a low lump, best pump to waste and begin printing with fresh mixed material.

If the appearance of the printed object is important, pump the standing material to waste and use fresh mixed material. Different consistencies will be evident in the printed layers.

10.2 OPTIMISING THE PRINTING QUALITY

The line quality can be adjusted by increasing or decreasing the.

1. Material flow rate
2. Printing speed

The success to 3DCP is finding the right material flow and print speed to produce a regular line quality.

If this is not successful, then other factors may be considered

- Rotor-stator
- Pipe diameter
- Nozzle diameter
- Line thickness, slicing etc.

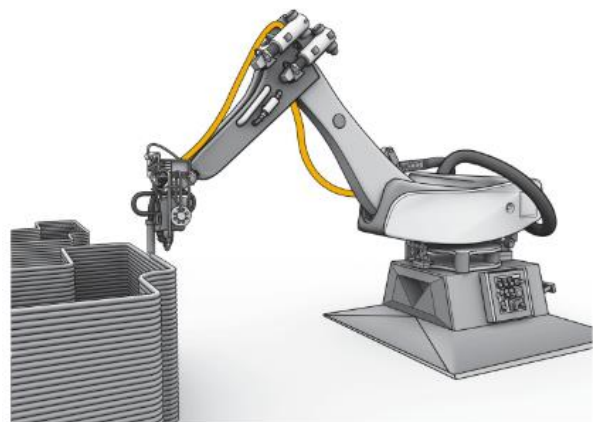

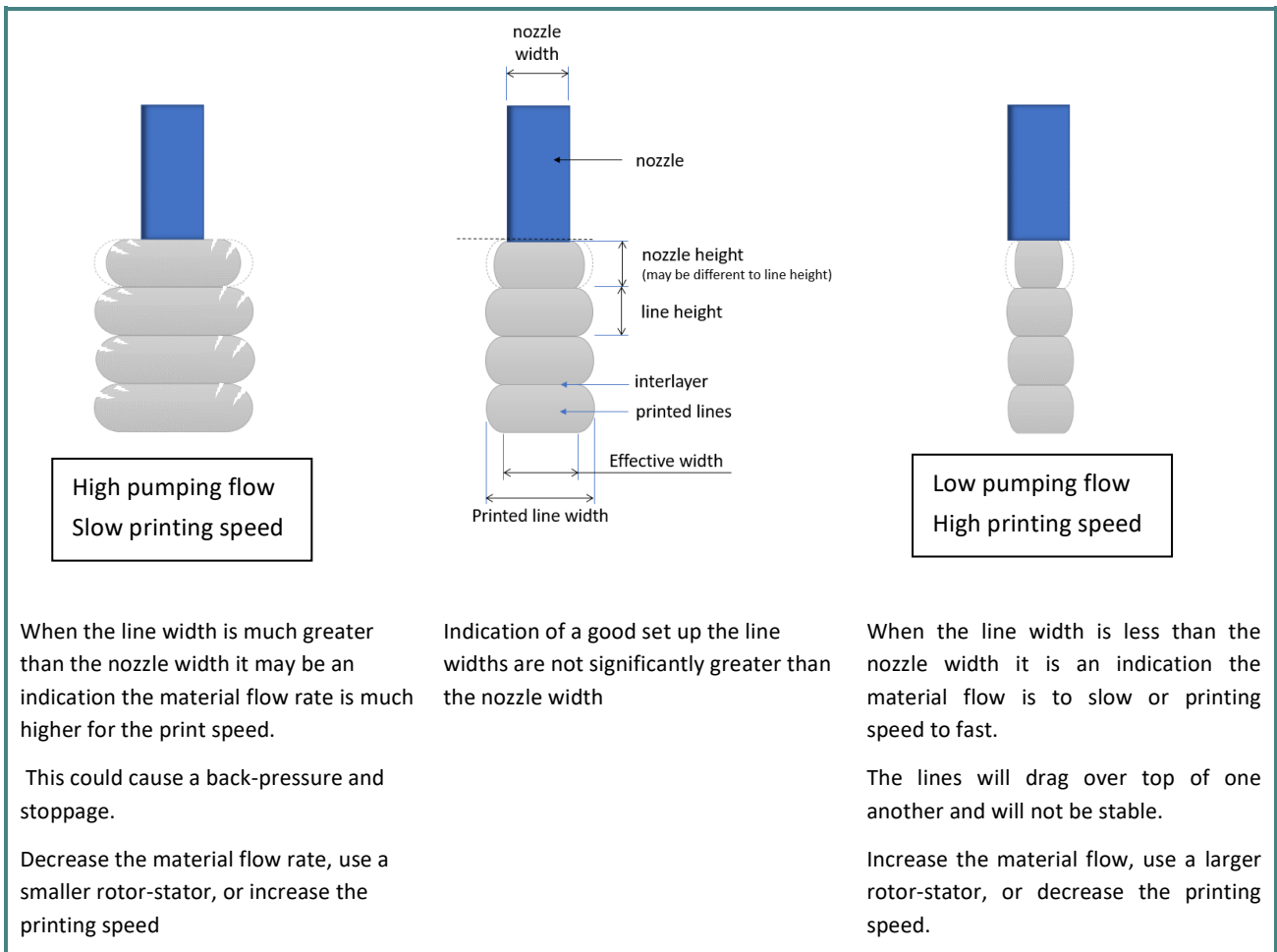

When the line width is much greater than the nozzle width it may be an indication the material flow rate is much higher for the print speed.

This could cause a back-pressure and stoppage.

Decrease the material flow rate, use a smaller rotor-stator, or increase the printing speed

Indication of a good set up the line widths are not significantly greater than the nozzle width

When the line width is less than the nozzle width it is an indication the material flow is too slow or printing speed too fast.

The lines will drag over top of one another and will not be stable.

Increase the material flow, use a larger rotor-stator, or decrease the printing speed.

10.3 CURE THE PRINTED OBJECTS

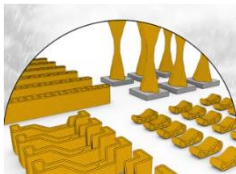

Cracking is often unsightly, unwanted and reduces durability. All printed objects shall be cured in accordance with the established best demonstrated practices for a cement-based material to prevent cracks from happening.

Temperatures cause the material to deform, expanding in heat and contracting in the cold. This deformation causes stress that can lead to cracks.

Fresh material shall be protected from.

- Premature drying due to wind, sun, and low humidity
- Extreme temperatures (cold and heat), frost
- Rapid temperature changes
- Thermal and physical shock
- Rain
- Chemical attack
- Mechanical stresses

Some curing methods will cause surface staining and therefore a pre-test is highly recommended.

Recognised curing methods

- Liquid curing agent (Sika® Antisol®)
- Water retaining covers
- White sheets (reflect sun)
- Black sheets (in cold temperatures)
- Misting continuously the surface with water
- Under water curing
- Climatic controlled curing room
- Shielding with a tent
- A combination of above

Apply liquid curing agent immediately after the shiny surface turns to a matt surface aspect making sure to cover completely the whole surface. Refer to the relevant PDS for application directions. Do not apply a curing agent if a layer or overcoat is to be added on the printed object. Refer to the coating PDS for further information or contact your local Sika Technical Department for further advice

Ensure water retaining covers are kept continuously moist. Do not saturate.

Ensure impervious sheets do not touch the fresh surface, that multiple sheets overlap sufficiently and ends are closed so that air cannot flow between the sheets.

Ensure when misting the printed object with water to maintain the surface continuous moist so that there is no wetting and drying (dark matt and light grey areas). Alternating wetting and drying can lead to stresses causing cracking. Do not use a direct water spray on a fresh concrete as this may erode the surface. Do not use water curing in freezing temperature conditions.

Use clean water tempered at approximately +20°C for curing underwater.

Apply the curing method as soon after printing as possible, especially if the printed object is exposed to an air flow or direct sunlight.

It is not sufficient at very low temperatures just to prevent water loss. To prevent excessive cooling use additional protective measures such as a warming blanket or warm the air around the printed object, whilst keeping the surface moist and relative humidity high. Do not blow warm air or place a heater next to the printed object.

In warm temperatures with low humidity the application shall always be protected from premature drying.

The length of the curing time always depends on multiple factors. The general guidance in EN 206 is 2- 4 days minimum.

Do not let stand exposed surfaces in ambient conditions less than 40% relative humidity, without applying a suitable curing.

10.4 MOVING THE PRINTED OBJECTS

In the early setting stages the material has no tensile capacity to resist stresses. Moving the printed object too soon is risky especially for tall slender objects or prints with a thin line width. Any stress may cause micro cracks that can propagate at a later stage.

The strength development is dependent on the water content and temperature, and therefore it is difficult to give definitive guidance, although the object shall not be moved until the material has sufficiently hardened.

Use the test print to determine a suitable moving time when the layers are sufficiently bonded.

The material hardening development can be improved by using an accelerated material like Sikacrete®-751 3D, or by curing the object in controlled warm temperatures with a high relative humidity. Do not cure in high temperatures with low humidity as this will cause cracking.

The printing company shall assess the minimum strength requirements for lifting heavy objects considering the weight of the object and lifting positions.

Take special care when transporting the printed object, even if it has achieved the final strength. Unreinforced mineral binder materials are still very brittle, especially with slender line widths.

Use packing that can absorb vibrations, sudden shocks and does not cause stresses to the printed object.

Consider packaging design, strap tightening positions and temporary strut positions when transporting the printed object.

10.5 FINAL USE OF THE PRINTED OBJECT

Sika is not responsible for the end use of the printed objects. Sika can recommend, provide, or assist with material testing to give an indication of the durability. Sika can also offer solutions to help extend the durability or service life of the printed object, such as protective coatings, renders, structural strengthening etc. Refer to your local Sika Technical Department for further assistance.

It is recommended to carry out pre-testing and field testing to check the suitability for use.

10.5.1 COLLECTING DATA

Data about printed objects will be an important topic of 3DCP for Engineers. Testing of the hardened properties can also be a form of quality control.

Design codes for casted concrete and mortars exist but are not yet transferred to 3DCP. This is explained by the RILEM Technical Committee.

“In traditional casting, concrete is generally placed in one continuous pour in a formwork and subsequently vibrated afterwards to obtain a homogenous and isotropic structural element, having similar properties in different directions. However, in case of 3D printed concrete, the elements are built-up from different filaments and anisotropy will occur in the material due to the applied print process and because of interface properties between the different layers” Source RILEM TC 276 I3D

One method is to test the compressive and flexure strength of the printed objects. Cubes, prisms, or cores can be extracted from a printed object, stored, and tested after the desired time. The values can also be compared with cast specimens.

Non-destructive testing like the rebound hammer could also be used to evaluate the strength development.

It is recommended to devise a repeatable procedure for printing and extracting samples for testing.

STEP	DESCRIPTION
1	Print a manageable sized object
2	Cure and store in the real-life conditions or remove after 1 day to controlled storage conditions
3	After 24 hours cut out and prepare the required specimen size for testing. Restore specimens to storage conditions.
4	Test in accordance with established Standards, modified for 3DCP for example EN 196-1, EN 12504-1 and ASTM C1107 after desired time.

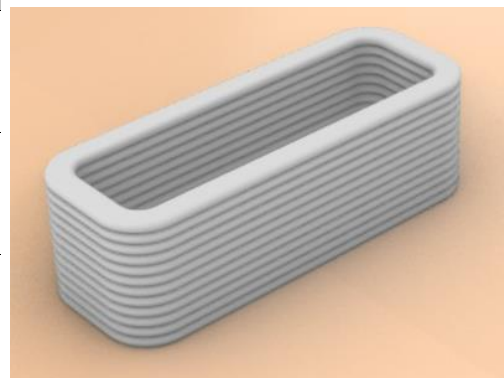

Examples of tests which can be performed on printed elements, using adapted existing Standards.

- Compression
- Flexure
- Modulus of Elasticity*
- Interlayer flexural strength
- Density
- Porosity
- Coefficient of thermal expansion
- Freeze-thaw
- Thundershower
- Carbonation
- Chloride resistance
- Sulphate resistance
- Water penetration

Testing printed objects has the following advantages because it takes into consideration.

- The actual recipe
- The ambient temperature and humidity conditions
- The actual setting time
- The interlayer time
- Curing
- Storage conditions

Due to these reasons, it may be expected the results will not always be the same every time which is why it is recommended to gather data throughout the year.

Example of testing printed samples in different directions to obtain the strength results.

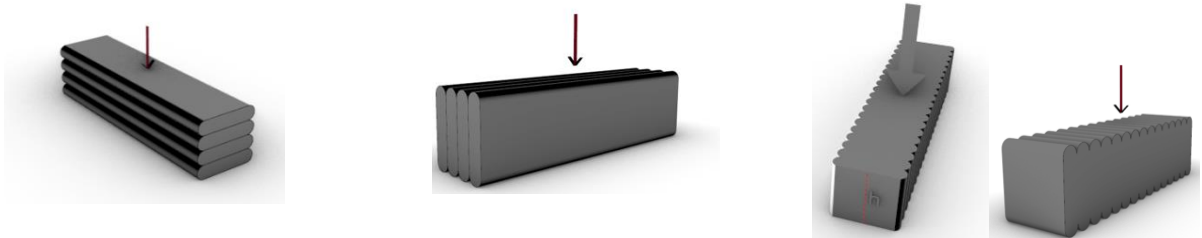

Compression test: Perpendicular to the layers; perpendicular to direction of layers and parallel to the layer direction

11 INSPECTION, SAMPLING AND QUALITY CONTROL

As part of “Good Practice” it is recommended at minimum to collect certain data about the printing session, and to use this data for improving the setting up procedure and equipment settings for future printing.

BEFORE PRINTING

DESCRIPTION	REFERENCE	FREQUENCY	PARAMETER
Ambient Temperature	Thermometer	Once	Within PDS limits
Ambient Humidity	Hydrometer	Once	Above 40%
Precipitation	Visual	Once	Keep records and provide protection
Wind Strength	Observation	Once	Keep records and provide protection
Delivered material	Visual	All pallets	No damage
Batch number	Delivery ticket	All pallets	Keep record
All tools and equipment	Visual	Once	Clean, no defect, dry, well maintained

DURING PRINTING

DESCRIPTION	REFERENCE	FREQUENCY	PARAMETER
Packaging	Visual	Every bag	No damage
Batch Number	On bag	All bags	Keep records
Dry product aspect	Visual	All bags	No lumps or hardened material
Mixed material temperature	Thermometer	Regular readings	A moderate increase in temperature compared to before mixing
Extruded material temperature	Thermometer	Regular readings	Approximately less than a +10 °C increase compared to the mixed material temperature
Water temperature	Thermometer	Regular readings	Keep records
Pressure readings	Pressure gauge	Regular readings	Not greater than equipment manufacturers recommendations
Mixed material	Visual	Every mix	Homogeneous, no lumps no un-mixed dry powder
Pot life	EN ISO 9514	Before printing	Keep records
Water content	Relative humidity probe Austrian microwave test	Every change of water content	Within PDS value
Workability	EN 13395-1 ASTM C939	Every change of water content	Within PDS values
Compressive Strength [cast samples]	EN 196-1 ASTM C1107	As required e.g., 12 hours, 1d, 3d, 7d, 14d, 21d, 28d, or 56d	Comparison with PDS values

METHOD STATEMENT

3D Concrete Printing using Sikacrete® 3D products
Oct 2023, Release 1
Copyright Sika® 2023

English version/Corporate
EN editor D Taylor

AFTER PRINTING

DESCRIPTION	REFERENCE	FREQUENCY	PARAMETER
Inspection	Visual	1, 3, 7, 14, 28 days	Record aspect and any defects
Compression strength [printed material]	EN 196-1 (modified) ASTM C1107 (modified)	See note 1	Keep records
Compression strength (core samples)	EN 12504-1	See note 1	Keep records

(1) The frequency of testing is the decision of the printing company. For some applications this type of testing is not required and for other applications testing may be specified as part of the project requirements. In general, it is recommended to **gain experience with the printed materials and collect data** for possible future use. This is not to say materials shall be tested every day. Experience can be gathered testing at different types of year, different materials, in different conditions and different times e.g., in hours or, 1, 3, 7, 14, 28 or 56 days. Again, not all these intervals are necessary.

12 CLEANING

Good cleaning and maintenance will ensure the better durability and longer service of the equipment, as well as helping to maintain a constant printing process. Cleaning shall be performed strictly in accordance with the equipment manufacturer's instructions.

In the context of cleaning this means "thoroughly" clean. Mineral binder materials when hardened can only be removed by mechanical means and any damaged part will need to be replaced. Special attention shall be made to all material that has dried on the equipment.

Do not use tools or implements that can scratch or damage the equipment.

The following is a guide to the cleaning frequency.

PRIORITY	EQUIPMENT DESCRIPTION	CLEANING FREQUENCY
1	Hose pipe	<ul style="list-style-type: none"> If print quality reduces Stoppage in hose At end of printing session or day Due to other equipment issue
2	Print head and nozzle	<ul style="list-style-type: none"> If print quality reduces At end of printing session or day After a stoppage or other equipment issue
3	Rotor-stator	<ul style="list-style-type: none"> If print quality reduces If pressure or temperature is too high At end of printing session or day After a stoppage or other equipment issue
4	Mixer	<ul style="list-style-type: none"> If print quality reduces If there is an excessive dry material lining At end of printing day After a stoppage or other equipment issue
5	Mixing pump	<ul style="list-style-type: none"> If print quality reduces If there is an excessive dry material lining At end of printing day After a stoppage or other equipment issue

The equipment Operator is responsible for correct assembly of the equipment and safety to operate before powering the equipment on again.

13 REDUCING STOPPAGES

Stoppages are time consuming and can damage equipment. The following table summarises the common causes of stoppages and suggestions for minimising the risk but is not limited to this list.

The first step in any stoppage is to address the hose and nozzle. Flush with extra water or remove and clean and then address the pump and mixer if the issue still occurs.

ITEM	POSSIBLE CAUSE OF STOPPAGE	MINIMISING THE RISKS
Sikacrete® 3D material	<ul style="list-style-type: none"> ▪ Hard lumps 	<ul style="list-style-type: none"> ▪ Do not store in or near humid, damp, or wet conditions ▪ Do not remove the protective packaging until ready for use ▪ Check packaging for damage on delivery and before use ▪ Use within shelf life
Conditions	<ul style="list-style-type: none"> ▪ High temperature working ▪ High equipment temperature ▪ Short pot life ▪ Fast hardening, low flow ▪ Material lining the equipment ▪ Back-pressure 	<ul style="list-style-type: none"> ▪ Protect material from sun ▪ Shelter equipment from sun, or work at night ▪ Condition water ▪ Protect the hose, use a white hose ▪ Increase slightly water dosage (not exceeding maximum in PDS) ▪ Regularly check rotor-stator temperature ▪ Regularly monitor mixing and extrusion temperature ▪ Reduce mixing energy ▪ More frequent cleaning breaks ▪ Check setting time
Forced action pan mixing	<ul style="list-style-type: none"> ▪ Too low or too high slump ▪ Lumpy material ▪ Sedimentation 	<ul style="list-style-type: none"> ▪ Use consistent water dosage ▪ Error measuring material and water weights ▪ Error zeroing scales ▪ Scales not calibrated ▪ Over mixing or under mixing time ▪ Check spread flow after every batch mix ▪ Check seals are not leaking ▪ Thoroughly empty the pan content after each batch
Pump Machine	<ul style="list-style-type: none"> ▪ No maintenance ▪ Rust and corrosion ▪ Un-clean ▪ Contamination ▪ Incorrect assembly ▪ Hot rotor-stator ▪ High pressure 	<ul style="list-style-type: none"> ▪ Service regularly (refer manufacturer's instructions) ▪ Inspect all parts for wear and/or damage ▪ Thoroughly clean ▪ Remove all hardened material ▪ Assemble in accordance with instructions ▪ Plan frequent cleaning breaks ▪ Do not use reducer in the hose or nozzle ▪ Correct rotor-stator selection
Hose pipe and nozzle	<ul style="list-style-type: none"> ▪ No lubrication ▪ Damaged hose ▪ Kinks or bend affecting flow ▪ Fast setting material ▪ High temperatures ▪ Back-pressure 	<ul style="list-style-type: none"> ▪ Thoroughly pre-lubricate hose ▪ Keep spares ▪ Lay to straight or gentle curves ▪ Use as short length hose as possible ▪ Correct nozzle selection ▪ Thoroughly clean after every use ▪ Use hose with uniform diameter ▪ Check pot life of material ▪ Protect from extreme conditions
Lubrication	<ul style="list-style-type: none"> ▪ Grains stuck in rotor-stator 	<ul style="list-style-type: none"> ▪ Over dosage water ▪ Sedimentation in slurry ▪ Worm too small for maximum grain size

METHOD STATEMENT

3D Concrete Printing using Sikacrete® 3D products

Oct 2023, Release 1

Copyright Sika® 2023

English version/Corporate

EN editor D Taylor

Pauses and Breaks	<ul style="list-style-type: none"> Material hardening in equipment 	<ul style="list-style-type: none"> Discuss daily objectives Plan breaks before starting Never leave mixed material un-attended Keep material agitated in the equipment Place a damp membrane over the hopper Extrude material before re-starting printing and check workability
Contamination	<ul style="list-style-type: none"> Foreign particles Changing products Packaging 	<ul style="list-style-type: none"> Take care opening bags Prevent packaging entering mixing Do not oil parts in contact with material

14 RECOMMENDED EQUIPMENT

The following continuous mixer-pump equipment are tested and suitable for use with selected Sikacrete® 3D 1-component products.

Equipment settings will depend on the product and factors discussed in this method statement. For further advice please contact your local Sika Technical Department for support.

If there are other equipment can be added to this list, we would like to hear from you. Please contact your local Sika Technical Department.

m-tec duo-mix connect and duo-mix 3DCP+



For further information contact m-tec mathis technik gmbh

Or visit their web site [3DCP - m-tec](http://www.3DCP-m-tec.com)

MAI 4MULTIMIX for 3DCP



For further information contact MAI International GmbH

Or visit their web site [3DCP - Mai](http://www.3DCP-Mai.com)

m-tec Connect SMP III 3DCP



For further information
contact m-tec mathis technik
gmbh

Or visit their web site
[3DCP - m-tec](#)

m-tec Connect P20V or P50V 3DCP



For further information
contact m-tec mathis technik
gmbh

Or visit their web site
[3DCP - m-tec](#)

15 MORE SIKA 3DCP SOLUTIONS

Sika® is a single source supplier who can help you add value for your customer offering.

Sika® BRAND NAME	PURPOSE
SikaRapid®	Accelerators to reduce setting time or speed up hardening
Sika® Care	Equipment protection
Sikacolor®	Colourings to enhance the appearance
SikaGrout®	Levelling or under grouting elements
Sikagard®	Hydrophobic impregnation and protective coating solutions
Sika MonoTop®	Hand and spray applied levelling layers
SikaTop®	Waterproofing render
EpoCem®	Levelling layer with higher chemical resistance
Sikaflex®	Sealing joints between elements
Sikadur®	Interlayer structural bonding
Sika Carbodur®	Structural strengthening
Sika Wrap®	Structural strengthening
Sika Anchorfix®	Anchoring fixing for lifting
Sikaceram®	Adhesive for bonding decorative features

16 EXAMPLE PRINT REPORT

[TITLE]

[insert CAD drawing]

[insert pictures]

DATA

Drawing Reference			
Objective (check radius, print angle, height, length, appearance):			
Test location			
Test date			
Machine operator			
PRODUCT NAME	Batch N°	Production date	

CONDITION AT START

Material temperature °C			
Water temperature °C			
Temperature & relative humidity			

MACHINE

Pump reference			
Mixer reference			
Rotor-stator reference			
Vertical mixing speed			
Hose diameter			
Hose length			
Nozzle diameter (mm)			
Print speed (mm/min)			

APPLICATION

Time	0 min	X min	Y min	Z min
Start time (h):				
Lubrication type				
Pre-mix temp. °C				
Boom speed				
Layer time minutes				
Layer				
Water dosage – L/M				
Mixing rate RPM				
Pumping rate RPM				
Outlet temp				
Stator top temp				
Stator bottom temp				
Material temperature				
Nozzle Temp C				
Print Temp C				
Layer width (mm)				
Layer thickness (mm)				
N° of layers				
Pump Pressure				
End time (h):				

RESULTS (appearance, smoothness, colour, accuracy, sag open time, homogenous mixing, air entrainment, cracks, etc.)

CONCLUSIONS (was it a successful print, any improvements, when could the element be moved)

SIGN and DATED

Operator			
----------	--	--	--



17 LEGAL NOTE

The information, and, in particular, the recommendations relating to the application and end-use of Sika products, are given in good faith based on Sika's current knowledge and experience of the products when properly stored, handled, and applied under normal conditions in accordance with Sika's recommendations. In practice, the differences in materials, substrates and actual site conditions are such that no warranty in respect of merchantability or of fitness for a particular purpose, nor any liability arising out of any legal relationship whatsoever, can be inferred either from this information, or from any written recommendations, or from any other advice offered. The user of the product must test the products suitability for the intended application and purpose. Sika reserves the right to change the properties of its products. The proprietary rights of third parties must be observed. All orders are accepted subject to our current terms of sale and delivery. Users must always refer to the most recent issue of the local Product Data Sheet for the product concerned copies of which will be supplied on request.

SIKA SERVICES AG
Target Market CONCRETE
Tueffenwies 16
8048 Zürich
Switzerland
www.sika.com

Version given by
D Taylor
Mail: taylor.david@ch.sika.com :

METHOD STATEMENT
3D Concrete Printing using Sikacrete® 3D products
Oct 2023, Release 1
Copyright Sika® 2023

English version/Corporate
EN editor D Taylor