



REFRIGERATED TRAILERS
AND CONTAINERS
FRESH IDEAS FOR COOL FREIGHT

BUILDING TRUST





FRESH IDEAS FOR COOL FREIGHT

Users and owners of modern trailers, refrigerated vans and containers demand lightweight and durable vehicles that insulate well and operate efficiently. Manufacturers are continually striving to develop vehicles to meet and exceed these targets and, at the same time, achieve faster build times, high rigidity and strength with optimum payload and longevity.

Sika, as a global partner to vehicle manufacturers, is able to provide bonding, assembly and sealing solutions and, importantly, the experience and know-how to assist manufacturers in achieving these targets.

CONTENT

04 Sandwich Panel Production

06 Body Assembly and Sealing

SANDWICH PANEL PRODUCTION

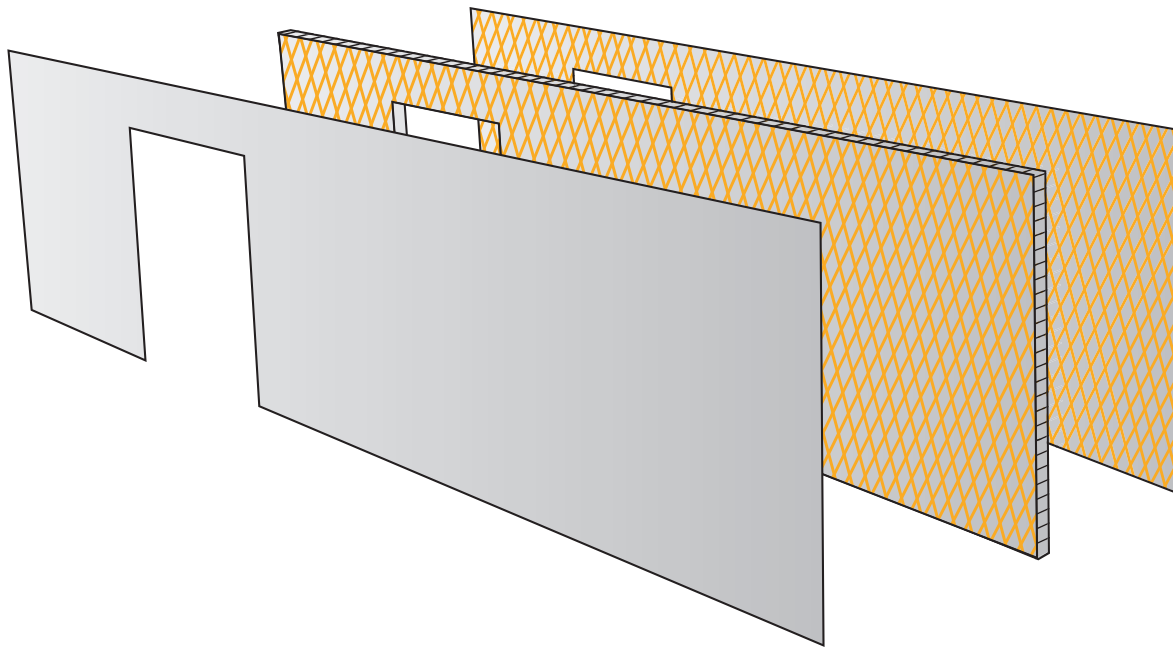

Trailer and container manufacturers use metal, wood, fibreglass and foam insulation in the production of side and rear walls, floors and roof structures. Increased efficiency in production is a critical factor for this competitive market place. Good thermal insulation and light-weight construction are required to provide enhanced performance and better fuel economy. The use of traditional fixing methods can result in buckling, deformation and denting of side and roof panels. Such issues require significant cost and labour to repair and rework. The use of adhesive bonding to fabricate the panels eliminates such risks and improves efficiency, quality and cost.

Sika provides solutions custom formulated to match with different customer process requirements. For example, systems are available with a wide range of press times, green strengths, open times and other key factors to adapt to the process needs of each customer's manufacturing requirements. We offer one-, two- and three-component polyurethane (PUR) technologies (SikaForce®), as well as reactive hot-melt (RHM) technology (SikaMelt®), for such applications.



SikaForce® applied by spreader bar

BEST RECOMMENDED SIKA PRODUCTS FEATURES AND BENEFITS

SikaForce®-7100

One-component PUR adhesive which foams during curing and can be easily processed

SikaForce®-7710

Two-component PUR adhesive for a wide range of sandwich panels with high strength and in a range of speeds

SikaForce®-7712

Three-component PUR adhesive with adjustable open and press times to achieve optimal productivity in varying conditions

SikaForce®-7717

Two-component PUR adhesive with the possibility for heat activation to achieve very short press times

SikaMelt®-9677

Reactive hot melt PUR adhesive for a range of panel lamination and with extremely fast cycle times



Positioning of the core foam

WHY USE SANDWICH PANEL ADHESIVE?

- Improved structural rigidity
- Lower panel weight, resulting in reduced total vehicle running costs
- Allows the use of high-performance foam cores to enhance thermal insulation
- Excellent water resistance
- Good process control, providing consistent and repeatable high-quality output
- Design flexibility

TECHNOLOGICAL BENEFITS

- Bonds well to a wide variety of substrates
- Faster production due to fast strength build-up
- Compatible with manual and automatic application processes
- Custom formulation to meet customer requirements
- Full range of adhesive technologies for sandwich panel lamination, including 3C-PUR, 2C-PUR, 1-C PUR and reactive hot melt PUR systems

ASSEMBLY OF THE BODY, SEALING AND BONDING IN INTERIOR AND EXTERIOR

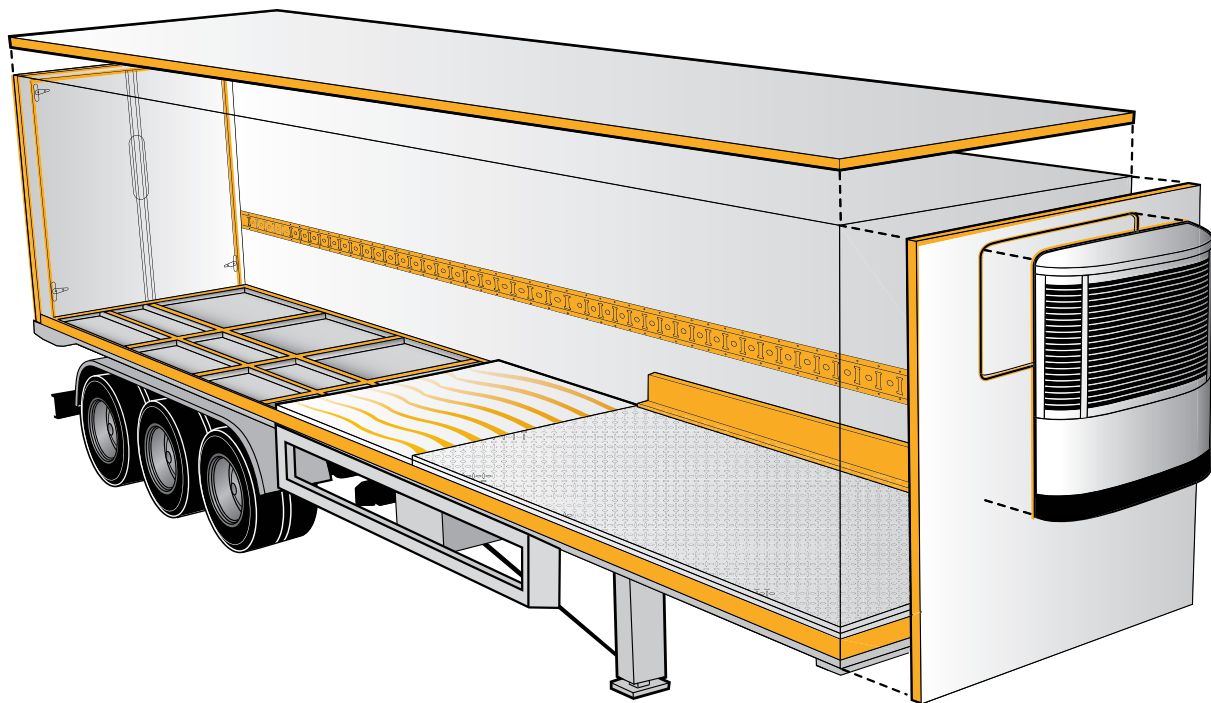

Recent years have seen dramatic changes in the styling and manufacturing of refrigerated trailers and containers. The mix of materials used to fabricate such equipment has also radically changed. The use of fiberglass composites and sandwich panel structures is now commonplace, as manufacturers seek to reduce vehicle weight, improve fuel economy, durability and enhance thermal insulation.

Sika can provide a range of high performance solutions for body assembly. SikaForce® two-component PUR adhesives demonstrate high strength, good flexibility and are capable of curing at room or elevated temperatures. Sikaflex® polyurethane sealants and adhesives combine simplicity of application with excellent durability and adhesion. Sikaflex® PUR-Hybrid, silane terminated polymer (STP) technology, combines the performance of traditional Sikaflex® polyurethane systems, but demonstrates additional benefits such as reduced substrate preparation and improved worker safety. SikaFast® two-component adhesives combine low surface preparation and high tensile strength with rapid de-jigging and full cure.



Assembly of the box

BEST RECOMMENDED SIKA PRODUCTS FEATURES AND BENEFITS

Sikaflex®-221

High-quality multi-purpose sealant and adhesive, suitable for making permanent elastic seals of high adhesive strength

Sikaflex®-228

Self-levelling, low viscous, one-component polyurethane adhesive for panel bonding

Sikaflex®-252

Structural assembly adhesive for flexible joints subjected to dynamic stresses

Sikaflex®-254 Booster

Fast curing; 'fail-safe' systems cures even in the absence of Sika® Booster Paste; good mechanical properties and adhesion

Sikaflex®-521 UV

Joint sealant with excellent UV, ageing and weather resistance, reduced substrate surface preparation needed. Solvent and VOC-free

Sikaflex®-552 AT

UV-stable assembly adhesive for sealing and bonding, excellent adhesion properties; suitable also for exterior joints

Sikaflex®-953

Two-component (10:1) Hybrid adhesive/sealant, good gap filling performance, pumpable over long distances

SikaForce®-7720

Two-component PUR high strength non-sagging thixotropic white adhesive for all types of assembly bonding

SikaForce®-7722

Two-component PUR high strength non-sagging thixotropic beige adhesive for all types of assembly bonding

SikaForce®-7724

Two-component PUR gelling type adhesive for assembly bonding with improved flow properties

WHY USE ASSEMBLY ADHESIVE?

- Higher rigidity of the structure without damage to thermal insulation – unlike mechanically fastened systems
- Lower weight, providing reduced running costs
- Excellent water resistance due to elimination of holes and drilling required by mechanical fasteners
- Improved aesthetics due to no visible fixings
- Reduced risk of warpage, as adhesives compensate for different thermal expansion rates between metal and nonmetal substrates
- Enhanced ability to withstand shock, impact and torsion

TECHNOLOGICAL BENEFITS

- Excellent balance of strength, flexibility and impact resistance
- Low thermal conductivity
- Excellent water resistance
- Wide range of cure speeds
- Superb adhesion to a wide range of substrates commonly used for trailer construction
- Suitable for automated or manual application
- Use of adhesives and sealants does not damage the vehicle corrosion protection layer, therefore reducing the likelihood of corrosion and repair work

GLOBAL BUT LOCAL PARTNERSHIP



FOR MORE TRANSPORTATION INFORMATION:



www.sika.com/truck-trailers

WHO WE ARE

Sika is a specialty chemicals company with a leading position in the development and production of systems and products for bonding, sealing, damping, reinforcing and protecting in the building sector and the motor vehicle industry. Sika has subsidiaries in 90 countries around the world and manufactures in over 160 factories. Its more than 17,000 employees generated annual sales of CHF 5,6 billion in 2014.

Our most current General Sales Conditions shall apply.
Please consult the Data Sheet prior to any use and processing.



SIKA SERVICES AG

Tueffenwies 16
8048 Zurich
Switzerland
www.sika.com

CONTACT

Phone: +41 58 436 40 40
Fax: +41 58 436 55 30
www.sika.com/truck-trailers

BUILDING TRUST

